



DTP 25[®] Tablet Press User Manual



We don't just sell machines—
we provide service.

Copyright Notice

© LFA Machines Oxford Limited, published in 2024 by LFA Machines Oxford Limited 2021. Registered in England and Wales, company number 08428898, registered office for service Demar House 14 Church Road East Wittering, Chichester, West Sussex, PO20 8PS.

All rights reserved. No part of this publication may be reproduced or transmitted, in any form or by any means, or stored in any retrieval system of any nature, without prior permission, except for fair dealing under the Copyright, Designs and Patents Act 1988, or in accordance with the terms of license issued by the Copyright Licensing Agency in respect of photocopying and/or reprographic reproduction. Application for permission for other use of the copyright material including permission to reproduce extracts in other published works shall be made to the publisher. Full acknowledgment of author, publisher and source must be given.

All trade marks are acknowledged and are owned by their respective owners.

Important Safety Information

READ THIS BEFORE OPERATING MACHINE

Intended Use

The intended use of this machine is to press dry raw materials into tablet form.

Potential misuse of this machine includes:

- Applying too much force to the powder.
- Trying to fill the Die with powder by hand.
- Inserting Tooling that is too big for the machine.
- Using powders that could explode under pressure.
- Using wet or damp material.

Personal Protection

For personal protection while transporting the DTP 25[®], abide by these actions:

- Use an engine hoist to lift the machine.
- Wear steel toe boots to prevent foot injury.
- Wear heavy duty grip gloves to ensure firm grasp on machine.
- Wear back support belt to prevent injury if needed.

For personal protection while operating the DTP 25[®], abide by these actions:

- Avoid wearing loose jewelry to prevent machine entanglement.
- Contain long hair to prevent machine entanglement.
- Wear safety goggles.
- Wear disposable latex/rubber gloves.
- Wear a hairnet (food grade products only).
- Wear a beard net if needed (food grade products only).

General Hazards

- Be aware of risk of entanglement and pinch point due to moving parts.
- Do not operate in a wet environment or with wet hands due to risk of electrical shock or burn.
- Do not operate if any wires are damaged, pinched, or frayed due to risk of electrical shock or burn.
- Keep out of reach of children.
- Keep fingers away from all moving parts.
- Ensure that it is secured to a workbench to prevent from falling.
- Inspect machine before use.
- Check that nuts and bolts are suitably tightened.
- Use this machine only for its intended use as described in this manual.
- Turn off and unplug the machine before conducting cleaning and maintenance.
- Do not modify the machine in any way.

Safety Assessment

It is critical to conduct a safety assessment to ensure that it complies with all local laws and industry accepted safety regulations.

If you require guidance on the installation of the machine or conducting a safety assessment, please contact LFA Machines.

Important Safety Information

READ THIS BEFORE OPERATING MACHINE

Symbols



WARNING

This signals potential risk for personal injury.



WARNING

This signals potential risk for electrical shock.



CAUTION

This signals potential risk for damage to the machine or other parts.

Modes for Stopping

In the case of an emergency during manual operation, immediately stop turning the Hand Wheel and remove yourself from the DTP 25[®].

In the case of an emergency during motor operation, immediately press the Emergency Stop button/turn the isolator switch and unplug.



Prop. 65 Statement for CA Residents

Based on LFA's current level of knowledge of our machines, the DTP 25[®] does not require a Proposition 65 warning label.

Warning for Explosive Material

This machine is not explosion proof. LFA recommends that you test your materials' explosivity before running them through this machine. If your materials are indeed explosive, do not use them with this machine.

Table of Contents

Copyright Notice	2
Important Safety Information	3
Intended Use	3
Personal Protection	3
General Hazards	3
Safety Assessment	3
Symbols	4
Modes for Stopping	4
Prop. 65 Statement for CA Residents	4
Warning for Explosive Material	4
DTP 25® Parts List	7
Preface	8
Training	9
Off-Site Training	9
Training via Video Chat/Phone	9
LFA Articles	9
LFA Videos	9
Installation	10
Tools and Materials Needed	10
The Appropriate Workstation for the Machine	10
Positioning the DTP 25®	12
Manual and Electrical Controls	14
Settings and Adjustment	17
Maintenance	23
General Maintenance Prescriptions	23
Lubrication	23
Dismantling for Repair and Replacement	27
Wear Parts and Causes of Damage	27
Tooling	28
Boot	34
Boot Teflon Pad	38
Troubleshooting	43
Common Machine/Part Issues	43
Common Tablet Issues	45
De-Jamming the DTP 25®	46
Cleaning	48
Storing the DTP 25®	56
Appendix	58
Glossary	58
Description of DTP 25® Parts	59
List of Electrical Components	64
Material of Contact Parts	65
Technical Specifications	65
Maintenance Checklist	66
Diagrams	67
Resources	85

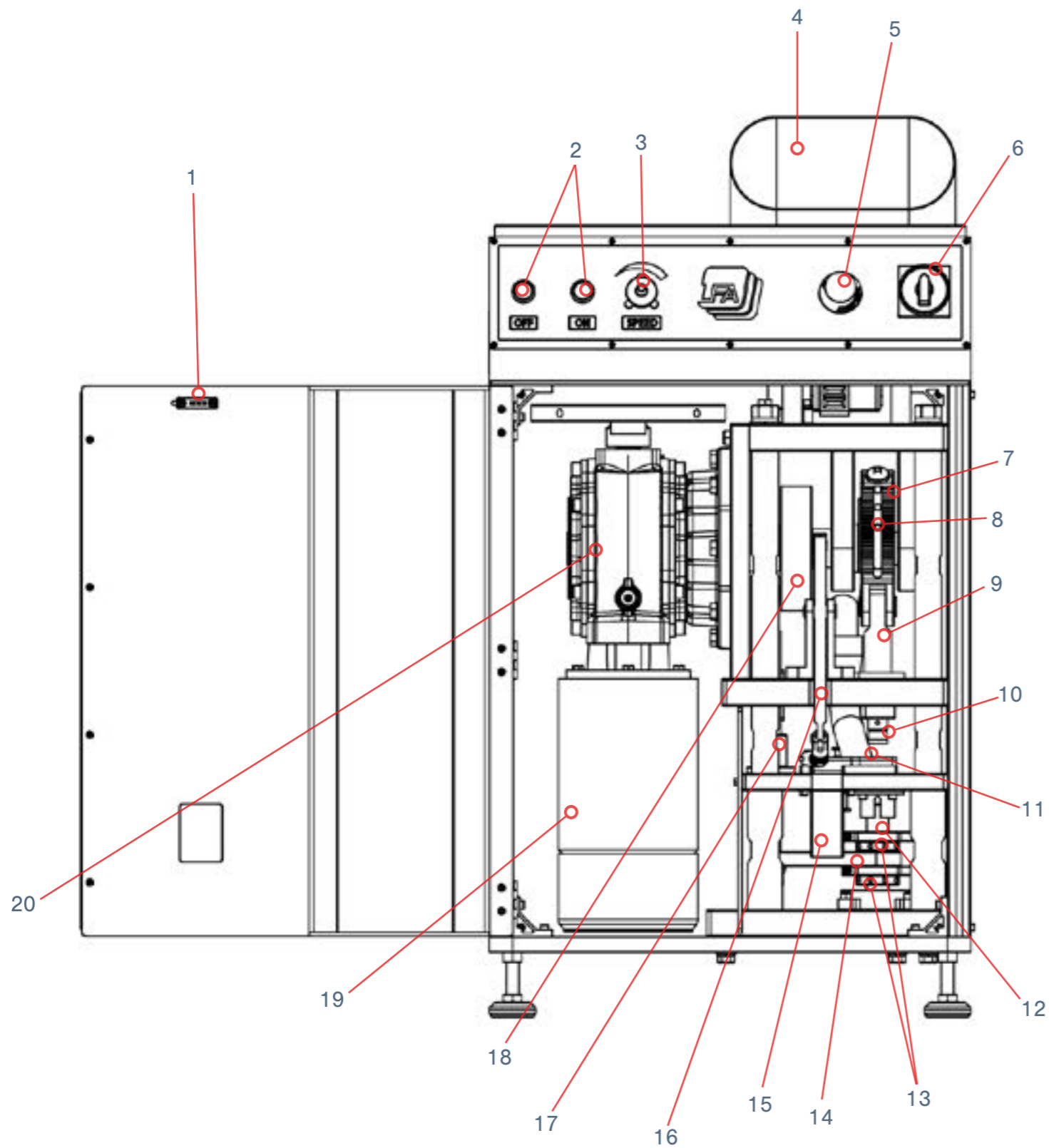

DTP 25[®] Parts List

1. Interlock Clip
2. Start/Stop Buttons
3. Operation Speed Adjustment
4. Hopper
5. Emergency Stop
6. Isolator Switch
7. Eccentric Sheave/Pressure Adjustment
8. Eccentric Sheave Inner Strap
9. Upper Drift Pin Assembly
10. Upper Punch
11. Boot
12. Lower Drift Pin Assembly
13. Lower Drift Pin Assembly Cogs/Adjustment Plate
14. Lower Drift Pin Assembly Lifting Bar
15. Ejection Tray
16. Boot Timing Bar
17. Lower Drift Pin Assembly Timing Rod
18. Lower Assembly Timing Cam
19. Motor
20. Gearbox

Preface



The DTP 25[®] is an advanced, single station press that makes tablet compression fast, easy, efficient, and safe. This compact machine is able to exert 100 kN of pressure to produce tablets up to 25 mm in diameter. With its features of protective casing, electronic control panel, and advanced feeder mechanism, the DTP 25[®] provides safety for operators, simple adjustments of parameters, and a maximum production of 1,500 tablets per hour. With an emphasis on convenience and accessibility, this tablet press is a cost-effective solution for users who seek moderate quantities of tablet production.

The purpose of this document is to support your understanding of the DTP 25[®]'s components, features, functions, and design. With this manual, you will be able to successfully operate and maintain your DTP 25[®] machine.

The user manual's content includes:

- Important safety information
- DTP 25[®] installation instructions
- Description of the DTP 25[®]'s operation
- DTP 25[®] maintenance information
- Appendix with supplemental information

Training

DTP 25[®] training is essential for the machine's successful operation and your personal safety. There are several methods to prepare you for working with the DTP 25[®].

Off-Site Training

LFA offers free training at our UK, USA, and Taiwan facilities for all our customers and their teams. For more information, go to <https://www.lfatabletpresses.com/services>

Training via Video Chat/Phone

Using an online video chat system, an LFA technician can interact face-to-face with you and assist with your understanding of the machine. Or, if you prefer, LFA can provide training via phone for all customers who call the office. To set up a training, call or email your local LFA office:

UK

Phone

+44 (0) 0345 165 20 25

Email

support.uk@lfamachines.com

USA

Phone

(682) 312-0034

Email

support.usa@lfamachines.com

Taiwan

Phone

+886 2773 74704

Email

support.asia@lfamachines.com

LFA Articles

LFA writes informative articles about desktop tablet presses, which includes instructions, procedures, and guides. To access the articles, go to <https://www.lfatabletpresses.com/articles>

LFA Videos

LFA has created several videos involving the DTP 25[®] and other desktop tablet presses. To access the videos, go to <https://www.lfatabletpresses.com/videos> or <https://www.youtube.com/user/TabletPilPress>

Installation

Tools and Materials Needed

Before you install and operate the DTP 25[®], it is best to have the following tools and materials on hand for general operation and maintenance:

- Engine hoist or lift and lifting strap
- Hammer
- Metric wrench set and adjustable wrench
- Circlip pliers and small needle nose pliers
- Flathead screwdriver
- Crosshead screwdriver
- Set of metric Allen keys with ball ends
- Long wire pipe cleaner
- Lubricant (NSF approved for food grade products)
- Grease gun
- Toothbrush
- Bagless vacuum
- Cleaner (e.g. Member's Mark Commercial Lemon Disinfectant)
- Sanitizer (e.g. Member's Mark Commercial Sanitizer)
- Cleaning brush set
- Plastic sheet or something similar to cover machine
- Safety goggles
- Disposable latex/rubber gloves
- Hairnet and/or beard net (food grade products only)
- Sterile shoe covers (food grade products only)

The Appropriate Workstation for the Machine

Find a stable workspace surface that supports the DTP 25[®]'s 332 kg (about 731.9 lbs) weight, such as a wooden bench (use stainless steel if for food grade industry). An important thing to consider is to find a bench that has a suitable working height for you. This machine has a single phase 220 V (± 10%) electrical requirement, so ensure that it is near an appropriate power plug.

Environmental Conditions

It is important that the environment in which you operate and store the DTP 25[®] has the appropriate temperature and relative humidity levels. These two environmental factors can potentially cause the machine to rust and/or cause the tablets to have a lower quality. The table below shows the acceptable temperature and relative humidity levels:

Machine	Temperature		Humidity
	°C	°F	
DTP 25 [®]	18-24	64-75	45-65% RH

The shipping crate will contain the following:

1. The assembled DTP 25[®]



2. The Tooling (already installed)



3. The De-Jamming Bar



Unpacking the DTP 25®

Tools Needed

- Crowbar
- Hammer

Instructions

1. Pry open each of the shipping container's paneling at the bottom with a crowbar and hammer to loosen it from the base.
2. Pry off the wooden panels from around the base with a crowbar and hammer.

Positioning the DTP 25®

WARNING: To prevent personal injury, wear steel toe boots and heavy duty grip gloves while transporting the DTP 25®.



LFA does NOT recommend carrying the machine manually but rather with an engine hoist. At least two people should be involved (one operating the engine hoist and one stabilizing the machine) in removing the machine from the shipping container and placing it in the workspace.

Transporting the DTP 25®

Tools and Materials Needed

- Engine hoist
- Adjustable wrench

Instructions

1. Open the top panel of the machine and set aside.
2. Secure the engine hoist onto the eyelet bolt attached to the top of the machine.



3. Carefully transport the machine to the desired workspace.
4. Raise the machine until there is sufficient room to adjust the anti-vibration feet from the pallet.
5. Loosen the bolts that secure the anti-vibration feet with an adjustable wrench.
6. Rotate the anti-vibration feet until they are at an adequate height and tighten their bolts with an adjustable wrench.

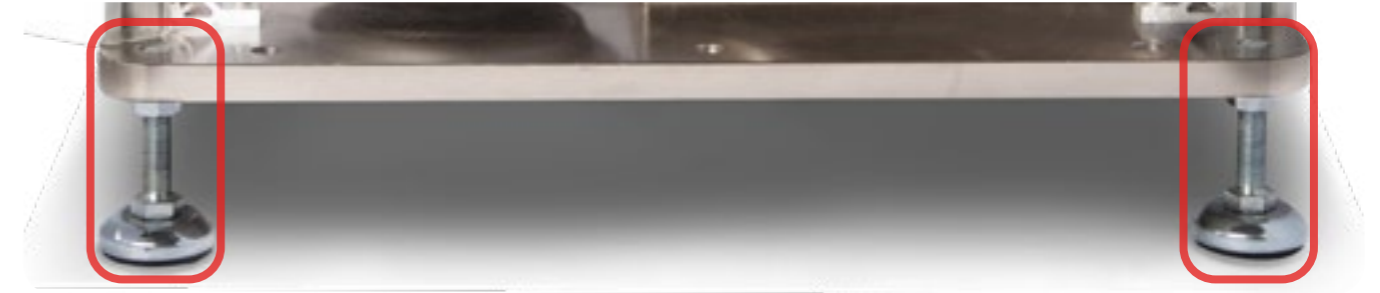

7. Carefully lower the machine to the ground.
8. Reinsert the top panel of the machine.

Manual and Electrical Controls

Basic Components



A description of the principal components follows:

- The **Top Cam** guides the punches' movement.
- The **Hopper** holds the dry materials that will be compressed.
- The **Boot** moves the materials from the Hopper to the Tooling and ejects the tablets.
- The **Die** defines or molds the size and shape of the powder.
- The **Upper Punch** and **Lower Punch** compress the materials within the Die.

DTP 25[®] Process

The basic mechanism of the DTP 25[®] involves filling the Tooling (Die, Upper Punch, and Lower Punch) with powder, compressing the powder, and ejecting the tablet.

Filling the Tooling with Powder

The dry materials are poured into the Hopper, which funnels the powder into the Boot. As the Hand Wheel is manually operated, the Top Cam withdraws the Upper Punch from the Die.

When the machine is operated by the motor, the Gearbox initiates the movement of the Top Cam, which withdraws the Upper Punch from the Die.

Compressing the Powder

After the powder is filled in the Tooling, the Top Cam drives the Upper Punch into the Die and the Lower Punch. Both punches then come together to compress the powder under high pressure.

Ejecting the Tablet

After both punches compress the powder into a tablet, the Top Cam withdraws the Upper Punch while the Lower Punch is pushed upward to expel the tablet. The tablet is then pushed out of the way by the Boot to prepare for the next tablet compression.



How to Create Tablets with the DTP 25®

Tools and Materials Needed

- Raw material formulation
- DTP 25®
- Safety goggles
- Disposable latex/rubber gloves (for food grade products and to protect hands from grease)
- Hairnet and/or beard net (food grade products only)
- Sterile shoe covers (food grade products only)



WARNING: For personal protection while operating the DTP 25®, contain long hair and do not wear loose jewelry.

Instructions

Note: Wear latex/rubber gloves (and appropriate food grade attire if applicable) during this process.

1. Pour the dry materials into the Hopper.
 - 1.1 Note: Ensure that the DTP 25® is unplugged from the electrical outlet.
2. Open the front Perspex door and rotate the Hand Wheel in the direction indicated by the arrow located on the Motor.
 - 2.1 Note: Always manually operate the DTP 25® for one rotation before running the machine.



3. Plug in the DTP 25® to an electrical outlet.
4. Press the green button (ON) to start operation and the red button (OFF) to stop.



Settings and Adjustment

The DTP 25's settings can be adjusted. Tuning the Tooling and adjusting the motor speed can help with changing the tablets' characteristics and how they are ejected from the machine.

Ejection Height

When the Upper Punch is fully lifted, the Lower Punch in its highest position should be flush with the Die:

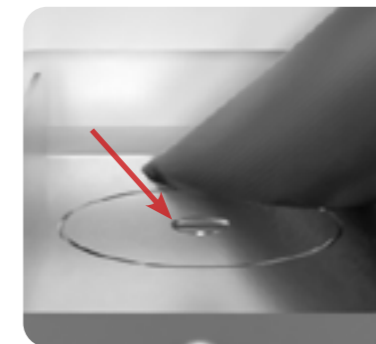

If the Lower Punch is above or below the Die's face, it will affect how smoothly the tablet is ejected. Adjusting the ejection height will help with this and can vary with different forms of Tooling.

Tools and Materials Needed

- Set of metric Allen keys with ball ends
- Disposable latex/rubber gloves (for food grade products and to protect hands from grease)
- Hairnet and/or beard net (food grade products only)
- Sterile shoe covers (food grade products only)



WARNING: To prevent any potential personal injury, unplug the DTP 25® from the electrical outlet

Instructions

Note: Wear latex/rubber gloves (and appropriate food grade attire if applicable) during this process.

1. Produce a test tablet to determine how the Tooling should be adjusted.
2. Open the front Perspex door.

3. Manually rotate the handle until the Lower Drift Pin Assembly is at its highest position and the Boot is at the position to push away the tablet.
4. Loosen the ejection height adjustment locking screw with an Allen key.
5. Insert an Allen key into one of the ejection height adjustment's holes and turn to adjust.
 - 5.1 Note: Turn clockwise to raise the ejection height. Turn counterclockwise to lower ejection height.



6. Tighten the ejection height adjustment locking screw with an Allen key.
7. Close the front Perspex door.

Fill Depth

At times, a tablet will be too light or too heavy, and its weight must change. Adjusting the fill depth determines the tablet's thickness and weight. This can be controlled by changing how high or low the Lower Punch sits.

Tools and Materials Needed

- Disposable latex/rubber gloves (for food grade products and to protect hands from grease)
- Hairnet and/or beard net (food grade products only)
- Sterile shoe covers (food grade products only)



WARNING: To prevent any potential personal injury, unplug the DTP 25® from the electrical outlet.

Instructions

Note: Wear latex/rubber gloves (and appropriate food grade attire if applicable) during this process.

1. Produce a test tablet to determine how the Tooling should be adjusted.
2. Open the front Perspex door.
3. Loosen the fill depth adjustment locking screw with an Allen key.
4. Insert an Allen key into one of the fill depth adjustment's holes and turn to adjust.
 - 4.1 Note: Turn clockwise to increase tablet weight. Turn counterclockwise to decrease tablet weight.



5. Tighten the fill depth adjustment locking screw with an Allen key.
6. Close the front Perspex door.

Motor Speed

The DTP 25®'s control console has a variable frequency drive (VFD) that can adjust the DTP 25®'s motor speed, which affects how quickly the machine operates and therefore tablet production speed.

Tools and Materials Needed

- Disposable latex/rubber gloves (for food grade products and to protect hands from grease)
- Hairnet and/or beard net (food grade products only)
- Sterile shoe covers (food grade products only)

Instructions

Note: Wear latex/rubber gloves (and appropriate food grade attire if applicable) during this process.

1. Turn on the machine to produce tablets.
2. Turn the dial on the VFD to adjust the production speed.
 - 2.1 Note: Rotate the dial clockwise to increase the production speed. Rotate the dial counterclockwise to decrease the production speed.



Punch Pressure

Sometimes tablets come out too soft and will crumble easily, which happens often after increasing the fill depth. Or, the machine can jam and will not be able to turn over. To correct this, the punch pressure needs to be adjusted in order to increase the tablet's firmness/de-jam the machine.

Tools and Materials Needed

- Adjustable wrench
- Disposable latex/rubber gloves (for food grade products and to protect hands from grease)
- Hairnet and/or beard net (food grade products only)
- Sterile shoe covers (food grade products only)



WARNING: To prevent any potential personal injury, unplug the DTP 25® from the electrical outlet.

CAUTION: Too much pressure adjustment can damage the machine/parts.

Instructions

Note: Wear latex/rubber gloves (and appropriate food grade attire if applicable) during this process.

1. Open the Perspex door and produce a test tablet to determine how the Tooling should be adjusted.



2. Rotate the pressure adjustment locking nut counterclockwise to loosen the pressure adjustment.
3. Raise or lower the pressure adjustment by hand to change the pressure.

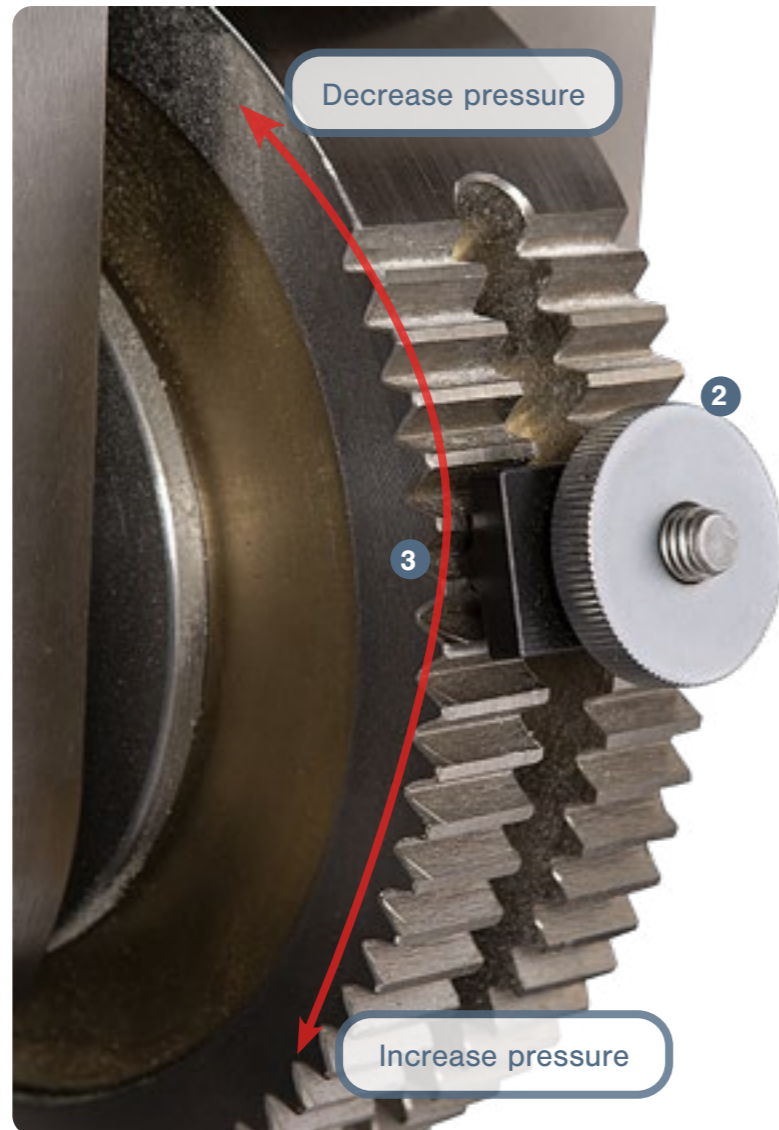

4. Ensure that the locking bar is in between a set of teeth on the Eccentric Sheave Strap and rotate the pressure adjustment locking nut clockwise.
5. Close the Perspex door.

Maintenance

To ensure that the DTP 25[®] will have a long operational life, maintenance is essential. This section includes methods for replacing parts, troubleshooting solutions, and how often to grease and clean your machines to keep its performance optimal.

General Maintenance Prescriptions

- Use the maintenance checklist (found in the Appendix) before, during, and after machine operation.
- Make sure all grease points are maintained and regularly lubricated.
- Use an appropriate amount of lubricant. Excess grease can drip into the tablets as they are formed.
- Before reassembling the machine after cleaning, make sure that the parts are dried and oiled.
- Constantly check for any loose nuts and/or screws before, during, and after machine operation.
- If the machine is not used for more than a week, place the Tooling in an airtight container and cover in lubricant.

Lubrication

Regularly greasing your machine is vital to prolonging its operational life. Parts that are not greased properly can make the machine seize up and cause major problems later. LFA recommends maintaining a lubrication schedule for your DTP 25[®], which can be found in this section.

Tools and Materials Needed

- Set of metric Allen keys with ball ends
- Disposable latex/rubber gloves (for food grade products and to protect hands from grease)
- Hairnet and/or beard net (food grade products only)
- Sterile shoe covers (food grade products only)



WARNING: To prevent any potential personal injury, unplug the DTP 25[®] from the electrical outlet.

Instructions (continued on next page)

Note: Wear latex/rubber gloves (and appropriate food grade attire if applicable) during this process.

1. Rub a finger's worth of grease on both of the Lower Assembly Timing Cam's sides.
1.1 Note: Be sure to lubricate the Boot Timing Cam runner and the Lower Drift Pin Assembly Timing Rod runner.

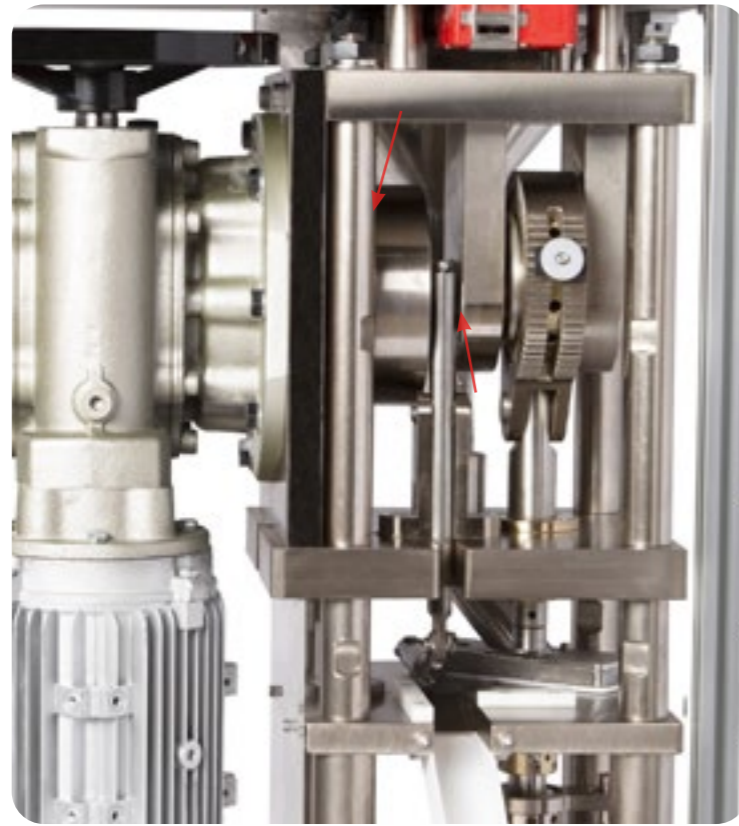

2. Lubricate the points at which the base and Upper Drift Pin Assembly meet.
3. Lubricate the points at which the base and Lower Drift Pin Assembly meet.





4. Lubricate the brass part in between the Eccentric Sheave Strap/Pressure Adjustment and Eccentric Sheave.



Lubrication Schedule

LFA recommends the following DTP 25® parts to be lubricated according to the following frequency:

Part	Location	Image	Frequency	Type of Lubricant
Tooling heads	The heads of the Upper Punch and Lower Punch		Visually inspect and apply when dry	Assembly Paste
Tooling (after cleaning)	Airtight storage container		Apply after cleaning	Mineral Oil
Gearbox	On top of the Motor		Visually inspect every week and top off when needed	460 Grade Worm Gear Oil
Upper Drift Pin Assembly	The point at which the Upper Drift Pin Assembly and base meet		Apply in the following situations: (a) after every 50,000 tablets, (b) after a deep clean, or (c) when the press has not been used for a prolonged period of time	NLGI Grade 2
Lower Drift Pin Assembly	The point at which the Lower Drift Pin Assembly and base meet		Apply in the following situations: (a) after every 50,000 tablets, (b) after a deep clean, or (c) when the press has not been used for a prolonged period of time	NLGI Grade 2
Lower Assembly Timing Cam	Cam tracks on both sides and runners on Lower Drift Pin Assembly Timing Rod and Boot Timing Bar		Apply in the following situations: (a) after every 50,000 tablets, (b) after a deep clean, or (c) when the press has not been used for a prolonged period of time	NLGI Grade 2
Eccentric Sheave and Eccentric Sheave Strap/ Pressure Adjustment	Brass part in between the Eccentric Sheave and Eccentric Sheave Strap		Apply in the following situations: (a) after every 50,000 tablets, (b) after a deep clean, or (c) when the press has not been used for a prolonged period of time	NLGI Grade 2

Dismantling for Repair and Replacement

Eventually due to wear and tear, some parts of the DTP 25® will need to be removed for repair and replacement. To prevent any delays in your tablet production, it is best practice to keep extra parts just in case.

To buy a DTP 25® part replacement, simply go to <https://www.lfatabletpresses.com/products/pill-press-machine-spare-parts/dtp-parts>

Warranty

To access LFA's warranty policy, go to <https://www.lfatabletpresses.com/warranty>
If your part is eligible for warranty, have your part's serial number on hand and please contact LFA:

UK
Phone
+44 (0) 0345 165 20 25
Email
support.uk@lfamachines.com

USA
Phone
(682) 312-0309
Email
support.usa@lfamachines.com

Taiwan
Phone
+886 2773 74704
Email
support.asia@lfamachines.com



WARNING: To prevent any potential personal injury, ALWAYS unplug the DTP 25® from the electrical outlet when replacing parts.

Wear Parts and Causes of Damage

Wear Part	Cause of Damage
Tooling	The Tooling can become chipped or broken. Lead times for a new set of Tooling can take as long as 6-8 weeks, so LFA recommends having a spare set or two.
Boot	This part can become trapped between the Die bore and the Upper Punch, which usually results from user error.
Boot Teflon Pads	On the bottom of the Boot there are three pads that are used to protect the Tooling and the Boot against the Die table. These pads are made from Teflon and are designed over time to wear to avoid damage to more expensive parts.

Tooling

If you want to change the shape and diameter of the tablet, or if the Upper Punch, Lower Punch, and/or Die you currently have is damaged, it is necessary to change the Tooling.

To buy new Tooling from LFA, simply go to <https://www.lfatabletpresses.com/products/tablet-press-tooling>

Tools and Materials Needed

- Set of metric Allen keys with ball ends
- Circlip pliers and small needle nose pliers
- Disposable latex/rubber gloves (for food grade products and to protect hands from grease)
- Hairnet and/or beard net (food grade products only)
- Sterile shoe covers (food grade products only)



WARNING: To prevent any potential personal injury, ALWAYS unplug the DTP 25® from the electrical outlet when replacing parts.

Instructions

Note: Wear latex/rubber gloves (and appropriate food grade attire if applicable) during this process.

Remove the Tooling

1. Remove the four screws securing the Hopper with an Allen key.



CAUTION: To prevent the Hopper from falling and becoming damaged, hold it in place while its four screws are being removed.

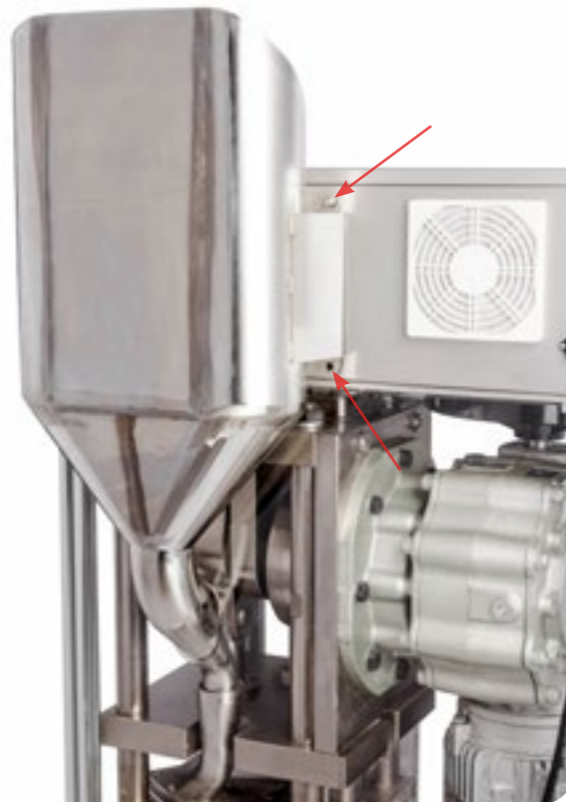

2. Remove the Hopper from the back Perspex panel and Boot.

3. Remove the four corner screws securing the back Perspex panel with an Allen key.



4. Remove the back Perspex panel from the machine.
5. Remove the circlip on the Boot Timing Bar Extender.
6. Remove the pin on top of the Boot with small needle nose pliers.

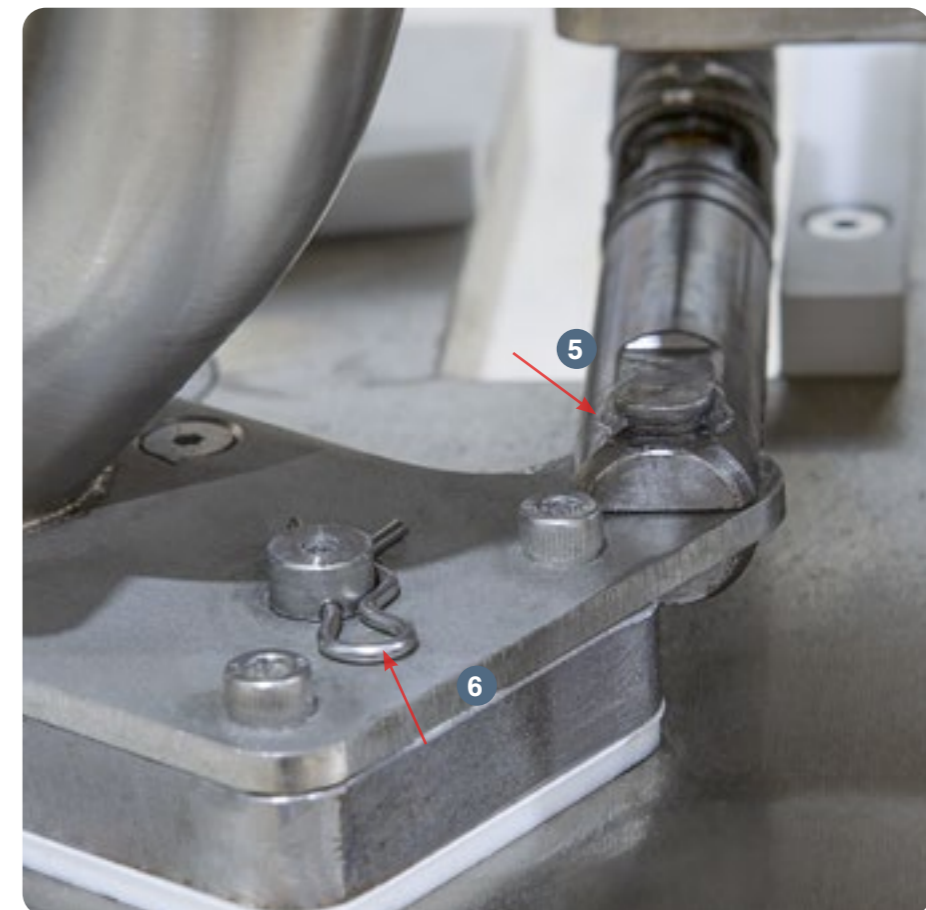

7. Pull down the Boot Bolt and Spring from the Boot.



8. Lift up the Boot and disengage it from the Boot Timing Bar Extender's pin.

9. Loosen the four bolts underneath the Ejection Tray with an Allen key and remove the Ejection Tray.

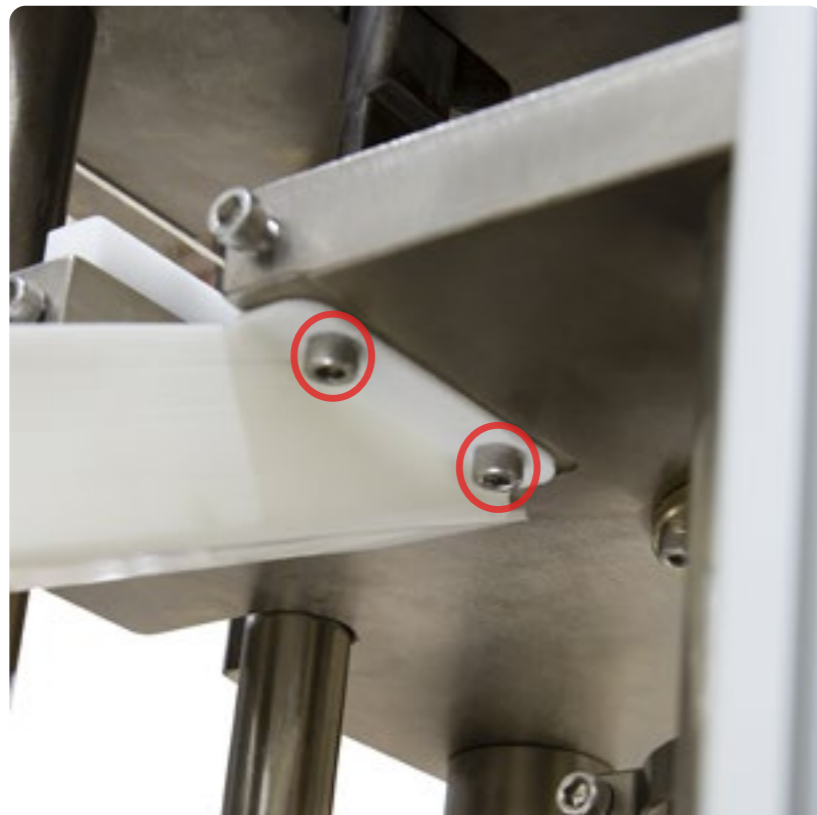

10. Remove the Ejection Tray and set aside.

11. Turn the Hand Wheel until the Upper Drift Pin Assembly is lowered.

12. Loosen the Upper Punch's screw with an Allen key.



13. Remove the Upper Punch by hand.

13.1 Note: If you cannot remove by hand, carefully use grippers or pliers.

14. Remove the righthand Perspex panel by unscrewing its four corner bolts with an Allen key.

15. Loosen the Die's screw on the righthand side of the Base Plate.



16. Slightly increase the ejection height of the Lower Punch.

16.1 Note: For more information, please refer to the ejection height adjustment instructions on page 17.

17. Rotate the Hand Wheel until the Lower Punch pushes up the Die from the Base Plate.

18. Remove the Die from the Base Plate.
19. Remove the bolt that locks the Lower Punch with an Allen key.



20. Remove the Lower Punch by hand.
 - 20.1 Note: If you cannot remove by hand, carefully use grippers or pliers.

Note: To help ensure that the Die is inserted correctly, LFA recommends using an Insertion Ring. You can order the Die Seat Cleaner and Insertion Ring on our website at <https://www.lfatablepresses.com/die-seat-cleaner-insertion-ring>



Replace the Tooling

21. Insert the new Lower Punch into the Lower Drift Pin Assembly.
22. Resecure the bolt that locks the new Lower Punch with an Allen key.
 - 22.1 Note: Make sure that the new Lower Punch's keyed section is facing toward the set screw.
23. Insert the new Die into the Base Plate and secure the Die's screw on the righthand side of the Base Plate.
24. Resecure the righthand Perspex panel using the four corner bolts and an Allen key.
25. Insert the new Upper Punch into the Upper Drift Pin Assembly.
26. Resecure the Upper Punch's screw into the Upper Drift Pin Assembly with an Allen key.
27. Rotate the Hand Wheel and carefully lower the new Upper Punch into the new Die.
 - 27.1 Note: Rotate the Hand Wheel to see that the new Upper Punch smoothly enters the new Die bore and that the new Upper Punch is seated firmly in the Upper Drift Pin Assembly.
28. Reattach the Ejection Tray with an Allen key.
29. Align the new Boot with the Boot Bolt and Spring's insertion point.
30. Insert the Boot Bolt and Spring up into the new Boot and hold it into place.
31. Reinsert the pin into the new Boot with needle nose pliers.
32. Insert the Boot Timing Bar Extender's pin into the new Boot and resecure it with circlip pliers.
33. Turn the Hand Wheel for one operation cycle to ensure that the machine runs smoothly before plugging it in and turning it on.
34. Resecure the back Perspex panel by tightening its four corner screws with an Allen key.
35. Insert the Hopper through the back Perspex panel and into the new Boot and hold it in place.
36. Resecure the Hopper to the machine with an Allen key.

Boot

Due to its constant movement, the Boot can wear down and prevent granular material from flowing smoothly. Replacing this part is a simple process.

Tools and Materials Needed

- Set of metric Allen keys with ball ends
- Circlip and small needle nose pliers
- New Boot part
- Disposable latex/rubber gloves (for food grade products and to protect hands from grease)
- Hairnet and/or beard net (food grade products only)
- Sterile shoe covers (food grade products only)



WARNING: To prevent any potential personal injury, ALWAYS unplug the DTP 25® from the electrical outlet when replacing parts.

Instructions

Note: Wear latex/rubber gloves (and appropriate food grade attire if applicable) during this process.

Remove the Boot

1. Remove the four screws securing the Hopper with an Allen key.



CAUTION: To prevent the Hopper from falling and becoming damaged, hold it in place while its four screws are being removed.

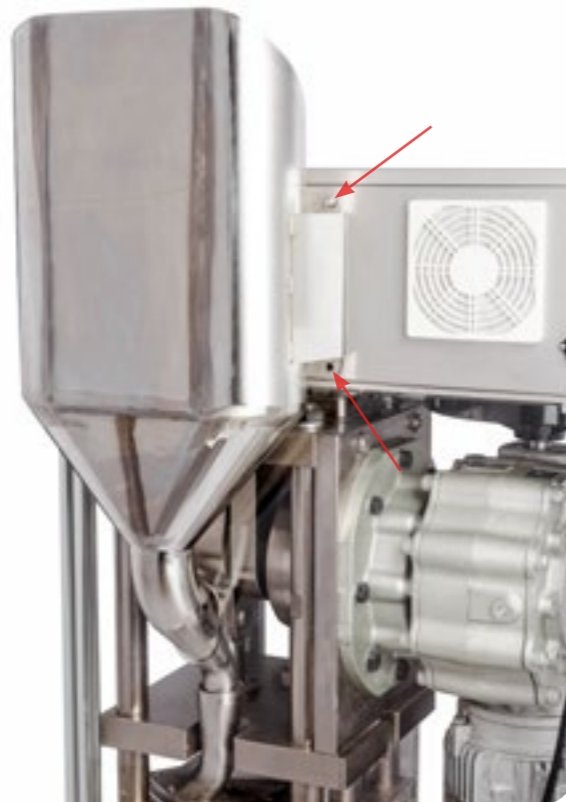

2. Remove the Hopper from the back Perspex panel and Boot.

3. Remove the four corner screws securing the back Perspex panel with an Allen key.



4. Remove the back Perspex panel from the machine.
5. Remove the circlip on the Boot Timing Bar Extender.
6. Remove the pin on top of the Boot with small needle nose pliers.

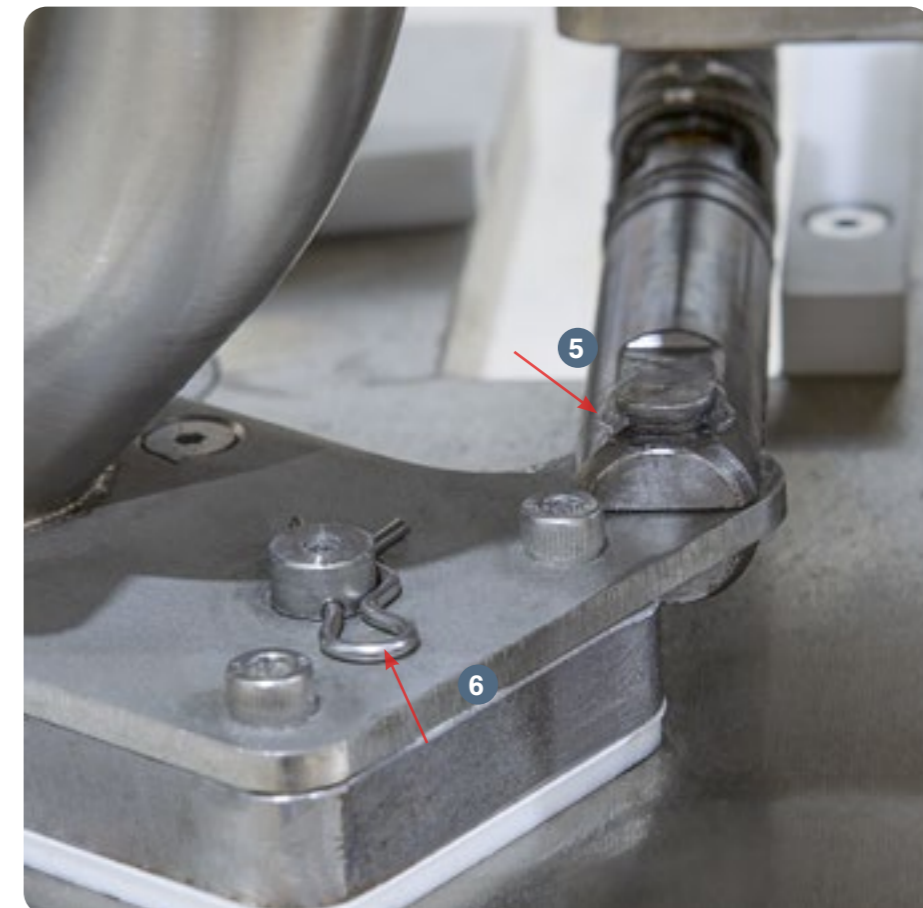

7. Pull down the Boot Bolt and Spring from the Boot.

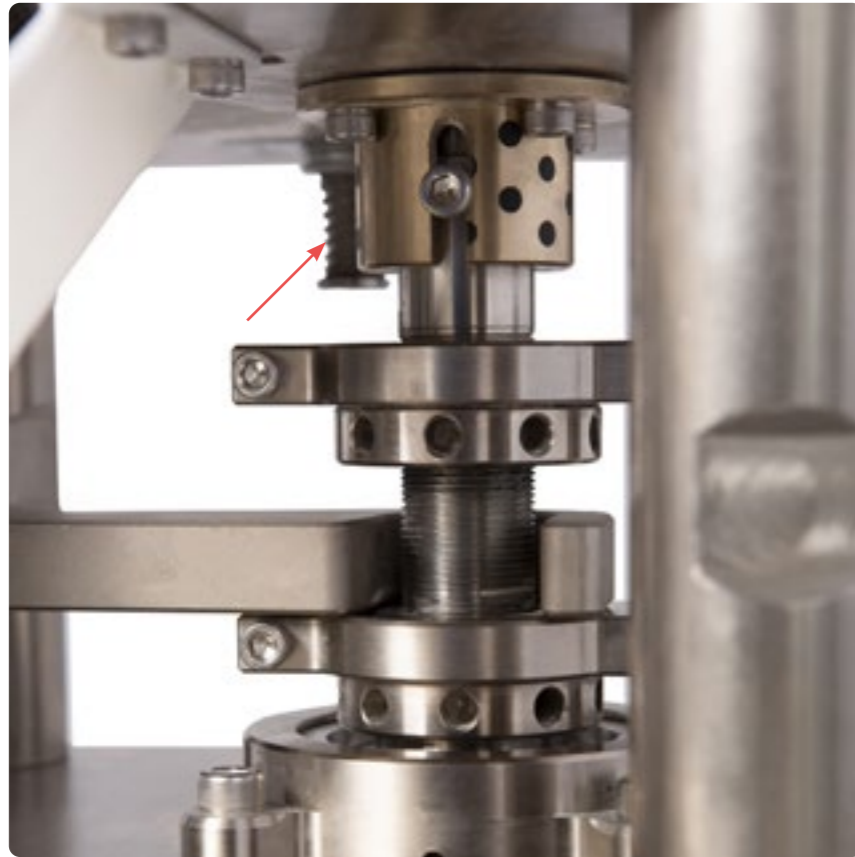

8. Lift up the Boot and disengage it from the Boot Timing Bar Extender's pin.

Replace the Boot

9. Align the new Boot with the Boot Bolt and Spring's insertion point.
10. Insert the Boot Bolt and Spring up into the new Boot and hold it into place.
11. Reinsert the pin into the new Boot with needle nose pliers.
12. Insert the Boot Timing Bar Extender's pin into the new Boot and resecure it with circlip pliers.
13. Turn the Hand Wheel for one operation cycle to ensure that the machine runs smoothly before plugging it in and turning it on.
14. Resecure the back Perspex panel by tightening its four corner screws with an Allen key.
15. Insert the Hopper through the back Perspex panel and into the new Boot and hold it in place.
16. Resecure the Hopper to the machine with an Allen key.

Boot Teflon Pad

The pad at the bottom of the Boot protects the Boot against the Base Plate. The Boot Teflon Pad is designed to wear over time to avoid damaging more expensive parts.

Tools and Materials Needed

- Set of metric Allen keys with ball ends
- Circlip pliers and small needle nose pliers
- New Boot Teflon Pad
- Disposable latex/rubber gloves (for food grade products and to protect hands from grease)
- Hairnet and/or beard net (food grade products only)
- Sterile shoe covers (food grade products only)



WARNING: To prevent any potential personal injury, ALWAYS unplug the DTP 25® from the electrical outlet when replacing parts.

Instructions

Note: Wear latex/rubber gloves (and appropriate food grade attire if applicable) during this process.

Remove the Boot Teflon Pad

1. Remove the four screws securing the Hopper with an Allen key.



CAUTION: To prevent the Hopper from falling and becoming damaged, hold it in place while its four screws are being removed.



2. Remove the Hopper from the back Perspex panel and Boot.

3. Remove the four corner screws securing the back Perspex panel with an Allen key.



4. Remove the back Perspex panel from the machine.
5. Remove the circlip on the Boot Timing Bar Extender.
6. Remove the pin on top of the Boot with small needle nose pliers.

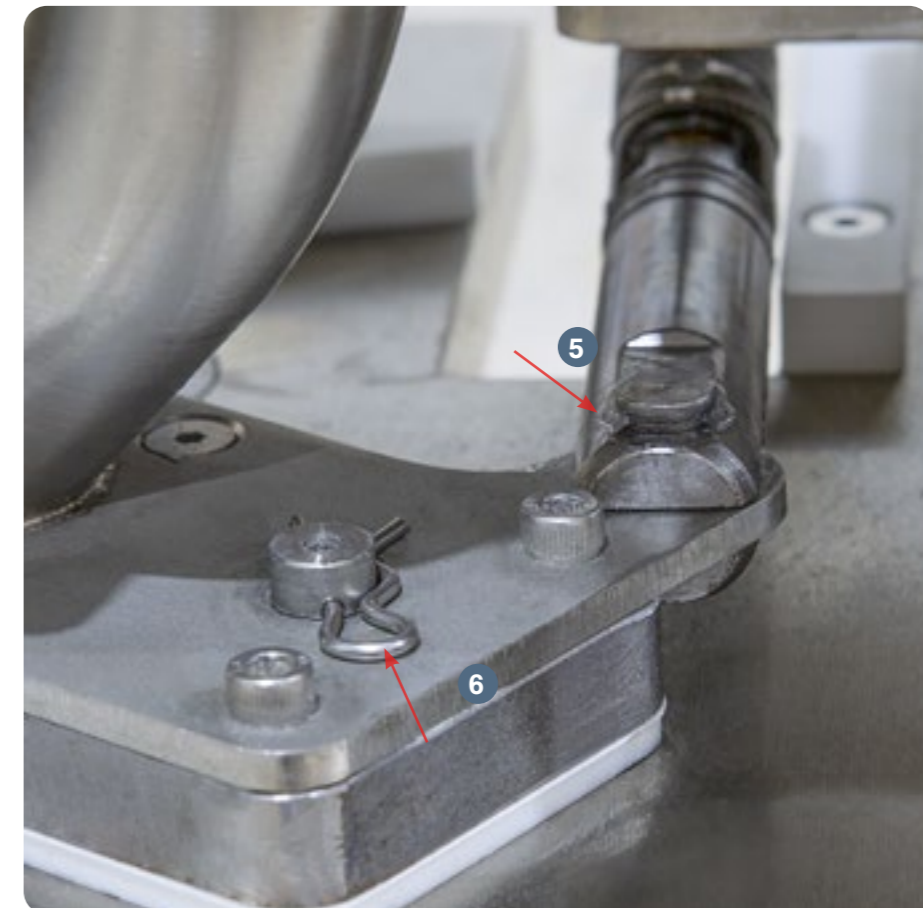

7. Pull down the Boot Bolt and Spring from the Boot.

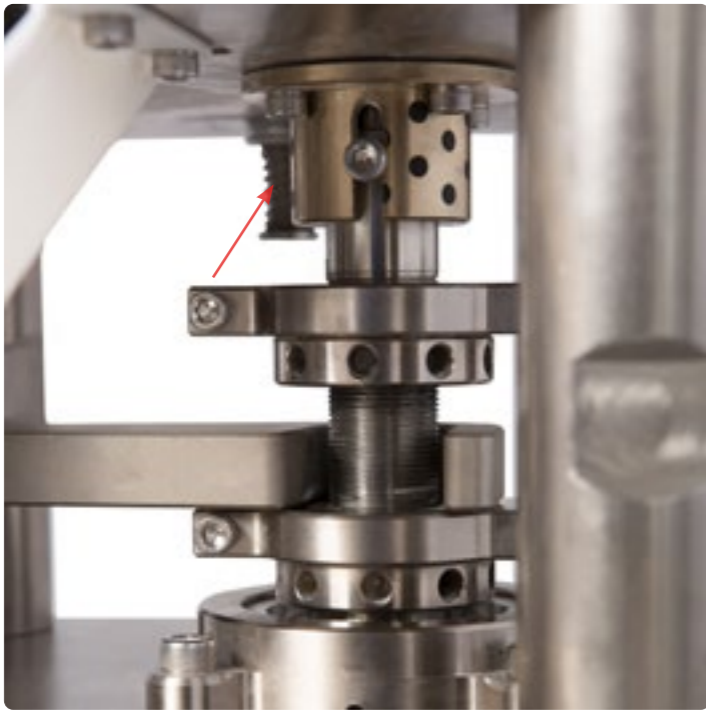

8. Lift up the Boot and disengage it from the Boot Timing Bar Extender's pin.

9. Turn over the Boot and remove each screw on the teflon pad with an Allen key.



10. Remove the Boot Teflon Pad.

Replace the Boot Teflon Pad

11. Align the new Boot Teflon Pad against its screw holes in the bottom of the Boot.
12. Screw in the new Boot Teflon Pad with an Allen key.
13. Insert the Boot Bolt and Spring up into the new Boot and hold it into place.
14. Reinsert the pin into the new Boot with needle nose pliers.
15. Insert the Boot Timing Bar Extender's pin into the new Boot and resecure it with circlip pliers.
16. Turn the Hand Wheel for one operation cycle to ensure that the machine runs smoothly before plugging it in and turning it on.
17. Resecure the back Perspex panel by tightening its four corner screws with an Allen key.
18. Insert the Hopper through the back Perspex panel and into the new Boot and hold it in place.
19. Resecure the Hopper to the machine with an Allen key.

Troubleshooting

Sometimes unavoidable issues will occur while operating the DTP 25[®]. Fortunately, there are several methods to remedy these issues.

Common Machine/Part Issues

Symptom	Possible Cause	Possible Solution
Machine freezes or locks up	Grease point areas are dry.	Regularly oil and grease all the Grease Nipple points.
	There is excess pressure on the Upper Drift Pin Assembly.	Lower the pressure on the eccentric sheave/pressure adjustment. Refer to page 21 for more information.
	The press is being started with the Upper Punch at a low point.	Adjust the starting position so that the Upper Punch is at the highest point.
Knocking sounds coming from machine	The Upper Drift Pin Assembly is slightly off.	Adjust the Upper Punch until it is aligned with the Die's bore.
	The Upper Drift Pin Assembly is not dropping smoothly in the powder filling stage of the process.	Check that there is not a buildup of powder between the Lower Punch and the Die. Then check that the Lower Drift Pin Assembly has enough clearance to drop through the hole in the machine's base.
Heavy resistance during production	The high friction areas are either unclean, locked, worn out, or not greased properly.	Clean and apply grease to all high friction areas on the machine.

Symptom	Possible Cause	Possible Solution
Inability to compact materials to tablet form	Boot is blocked and not enough materials are flowing out.	Check the Boot for a potential clog.
	The Boot Timing Bar is not secured.	Tighten the Boot Timing Bar's screw.
	There is not enough pressure.	Increase the pressure on the eccentric sheave/pressure adjustment. Refer to page 21 for more information.
	The Lower Punch is broken.	Remove the Lower Drift Pin Assembly to access the broken Lower Punch. After removing it, replace the Tooling.
	The Lower Drift Pin Assembly is not dropping properly during filling.	Check that there is not a buildup of powder between the Lower Punch and the Die. Then check that the Lower Drift Pin Assembly has enough clearance to drop through the hole in the base.
	There are flowing issues with the mix.	If the machine is able to make tablets with LFA's Firmapress®, then the problem is your mix. Adjust your formulation. If still an issue, contact LFA for support.
Powder sticks to the Upper Punch	There is damage to the Tooling or the Tooling's design is causing sticking.	Remove and replace the Tooling (Upper Punch, Lower Punch, and Die).
	There are issues with the mix.	Adjust your formulation. If still an issue, contact LFA for support.
Powder sticks to the Lower Punch	There are issues with the mix.	Adjust your formulation. If still an issue, contact LFA for support.

Common Tablet Issues

Symptom	Possible Cause	Possible Solution
Double tablets	Previous tablet did not eject correctly.	Remove the double tablet manually from the Die bore.
	Excess granular materials were placed in the Die, which prevented the ejection of the existing tablet.	Clean the Tooling to remove any excess granular materials and make sure that it is clean and completely dry.
Cracked or broken tablets	There are problems with the formulation of the granules and ingredients.	If the machine is able to make tablets with LFA's Firmapress®, then the problem is your mix. Adjust your formulation. If still an issue, contact LFA for support.
	The Boot is not feeding enough material to be pressed in tablet form.	
	There is excess pressure.	Please read our article on Capping at https://www.lfatabletpresses.com/articles/tablet-capping
Shattered tablets	The Boot Timing Bar and the Boot are not adjusted properly.	Adjust the Boot Timing Bar by loosening/tightening its bolt and moving it.
	Air is becoming trapped in the tablet during compression.	Please read our article on Capping at https://www.lfatabletpresses.com/articles/tablet-capping
Inconsistent tablet weight	There are flowing issues with the mix.	If the machine is able to make tablets with LFA's Firmapress®, then the problem is your mix. Adjust your formulation. If still an issue, contact LFA for support.
Soft tablets	There is too little punch pressure.	Increase the pressure on the eccentric sheave/pressure adjustment. Refer to page 21 for more information.
	There are flowing issues with the mix.	If the machine is able to make tablets with LFA's Firmapress®, then the problem is your mix. Adjust your formulation. If still an issue, contact LFA for support.
Uneven tablets	The Tooling is worn out.	Check the ingredients of your formula before you replace the Die, Upper Punch, and Lower Punch.

De-Jamming the DTP 25®

There are several reasons why a DTP 25® might jam such as:

- The fill depth is set too low and the pressure is set too high.
- There is a build up of powder sticking to the Tooling.
- Any powder buildup on the machine can cause tablets to eject backwards and not forwards, creating potential for a double tablet becoming stuck in the Die's bore.



WARNING: To prevent any potential personal injury, ALWAYS unplug the DTP 25® before de-jamming it.

Tools and Materials Needed

- Set of metric Allen keys with ball ends
- Disposable latex/rubber gloves (for food grade products and to protect hands from grease)
- Hairnet and/or beard net (food grade products only)
- Sterile shoe covers (food grade products only)

Instructions

Note: Wear latex/rubber gloves (and appropriate food grade attire if applicable) during this process.

Method 1: Lower the Pressure

1. Open the front Perspex door.
2. Rotate the pressure adjustment locking nut counterclockwise to loosen the pressure adjustment.
3. Raise the pressure adjustment by hand to lower the pressure.
4. Rotate the press by hand to ensure that it moves freely.



Method 2: Increase the Fill Depth

1. Open the front Perspex door.
2. Loosen the fill depth adjustment locking screw with an Allen key.
3. Insert an Allen key into one of the fill depth adjustment's holes and turn clockwise to increase the fill depth.



Method 3: Use the De-Jamming Bar

1. Remove the Hopper from the Boot and out of the back of the Perspex case.
2. Remove the back Perspex panel.
3. Open the front Perspex door.
4. Remove the Boot Timing Bar Extender from the Boot with circlip pliers.
5. Remove the pin on top of the Boot with small needle nose pliers.
6. Remove the Boot Bolt and Spring underneath the Boot with an adjustable wrench.
7. Remove the Boot from the machine.
8. Insert the De-Jamming Bar into one of the holes on the Hand Wheel.
9. Pull the De-Jamming Bar inside the Hand Wheel counterclockwise until the machine gives way.
 - 9.1 Note: This is the only situation in which the machine should be manually operated backwards.



Cleaning

During the DTP 25®'s operation, excess powder will find its way into parts of the machine, particularly in the Hopper, Boot, Tooling, and base. It is important to clean the DTP 25® thoroughly to prevent rusting and cross contamination.

LFA recommends that the machine be cleaned after each operation.

Tools and Materials Needed

- Cleaning brush
- Long wire pipe cleaner
- Toothbrush
- Cleaner (e.g. Member's Mark Commercial Lemon Fresh Disinfectant)
- Set of metric Allen keys with ball ends
- Disposable latex/rubber gloves
- Bagless vacuum
- 3 clean cloths
- Potable water
- Bowl of warm soapy water (nothing abrasive)
- Sanitizer (e.g. Member's Mark Commercial Sanitizer)
- Hairnet and/or beard net (food grade products only)
- Safety goggles
- Sterile shoe covers (food grade products only)



WARNING: To prevent any potential personal injury, ALWAYS unplug the DTP 25® from the electrical outlet when replacing parts.

Instructions

Note: Wear safety goggles and latex/rubber gloves (and appropriate food grade attire if applicable) during this process.

Remove Parts

1. Open the front Perspex door.
2. Remove the Ejection Tray from the machine by loosening its four screws with an Allen key.

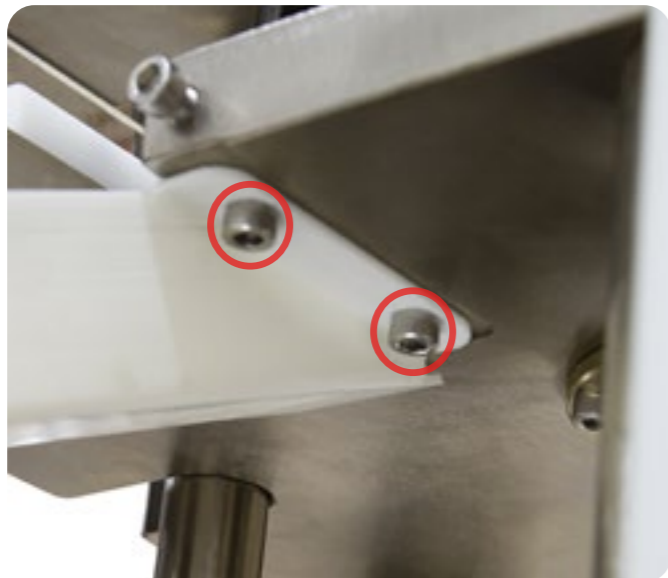

3. Remove the four screws securing the Hopper with an Allen key.



CAUTION: To prevent the Hopper from falling and becoming damaged, hold it in place while its four screws are being removed.

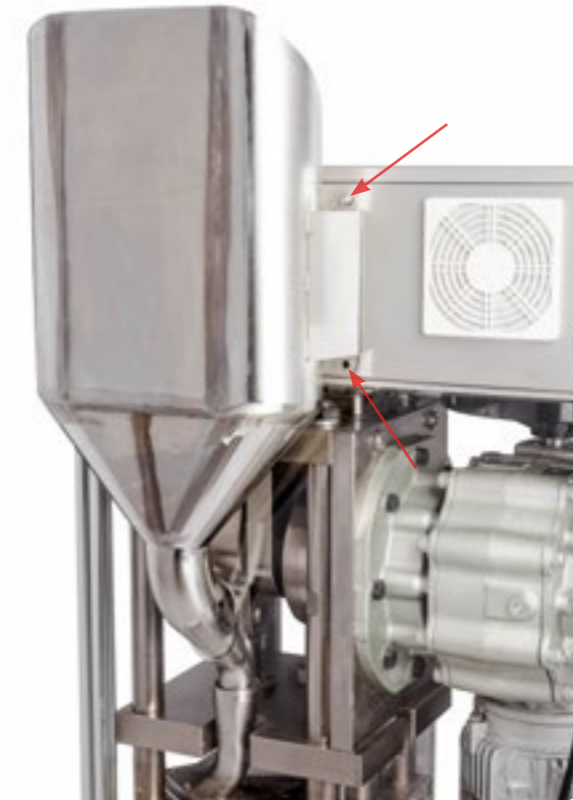

4. Remove the Hopper from the back Perspex panel and Boot.

5. Remove the four corner screws securing the back Perspex panel with an Allen key.

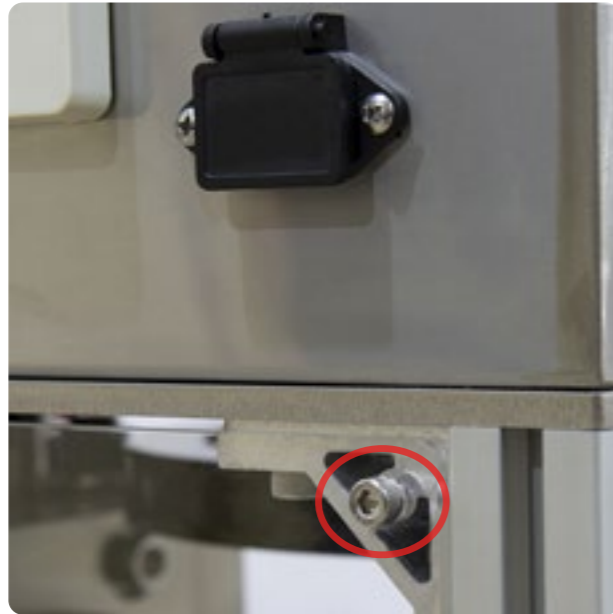

6. Remove the back panel from the machine.

7. Remove the circlip on the Boot Timing Bar Extender.

8. Remove the pin on top of the Boot with small needle nose pliers.

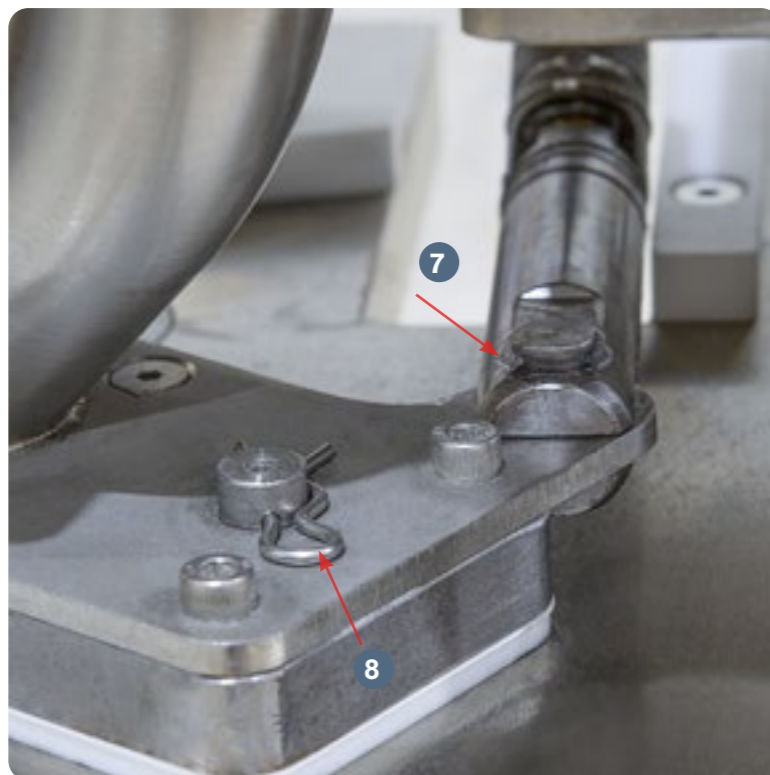

9. Pull down the Boot Bolt and Spring from the Boot.

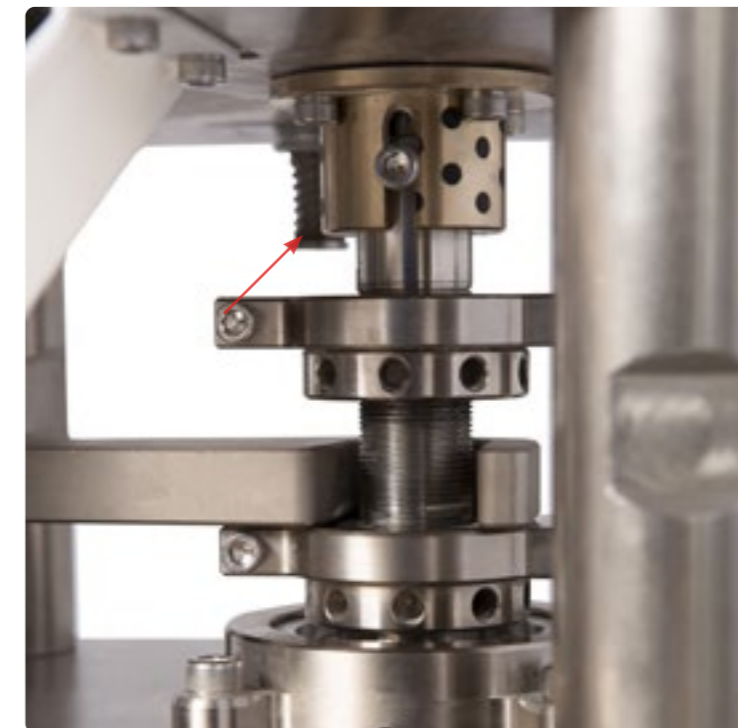

10. Lift up the Boot and disengage it from the Boot Timing Bar Extender's pin.

11. Disassemble the Boot by loosening the screws on the top and bottom of the part with an Allen key.



12. Turn the Hand Wheel until the Upper Drift Pin Assembly is lowered.
13. Loosen the Upper Punch's screw with an Allen key.



14. Remove the Upper Punch by hand.
14.1 Note: If you cannot remove by hand, carefully use grippers or pliers.
15. Remove the righthand Perspex panel by unscrewing its four corner bolts with an Allen key.
16. Loosen the Die's screw on the righthand side of the Base Plate.

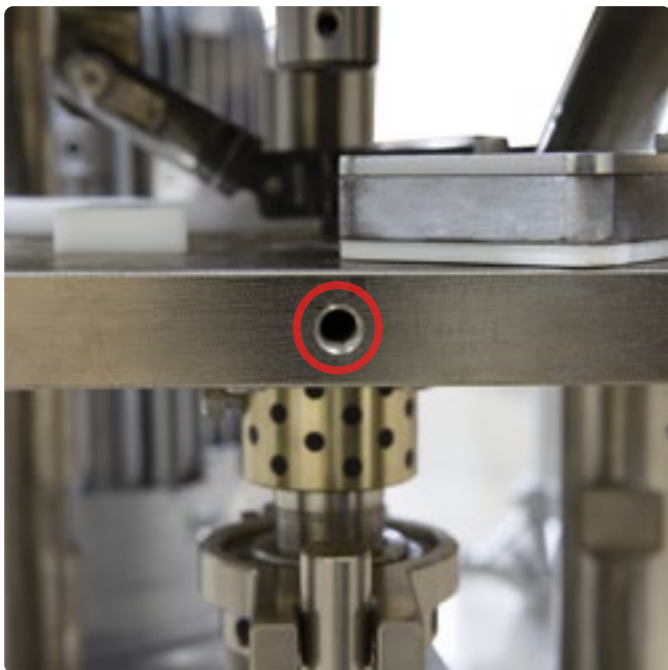

17. Slightly increase the ejection height of the Lower Punch.
17.1 Note: For more information, please refer to the ejection height adjustment instructions on page 17.
18. Rotate the Hand Wheel until the Lower Punch pushes the Die from the Base Plate.

19. Remove the Die from the Base Plate.
20. Remove the bolt that locks the Lower Punch with an Allen key.



21. Remove the Lower Punch by hand.
21.1 Note: If you cannot remove by hand, carefully use grippers or pliers.

Clean the Base

- 22. Vacuum any powder/debris from the machine.
- 23. Spray the DTP 25® base with the cleaner, particularly in the Tooling's location.
- 24. Rinse the cleaner off with potable water and dry immediately with a clean cloth.
- 25. Sanitize the DTP 25® base with a clean cloth.

Clean the Parts

- 26. Take one of the parts removed from the machine and submerge it in the bowl of warm soapy water.
 - 26.1 Note: To ensure that all dirt and debris are removed, wash one part at a time.
- 27. Take a clean cloth and carefully wash the part thoroughly.
 - 27.1 Note: Use the toothbrush for difficult-to-remove debris. When cleaning tooling, use non-abrasive cleaning equipment such as a soft pipe cleaner and soft cloth.
- 28. Dry part immediately after it is cleaned and rinsed.
- 29. Sanitize part with a clean cloth.
- 30. Repeat steps 26-29 for each remaining part until they are all clean.



Cleaning Schedule Matrix

Part	Frequency							
	After installing machine	After every use	Before every use	In between products that present a cross-contamination risk	Weekly	Monthly	Before placing in storage	After removing from storage
Ejection Tray	Remove from machine	Remove from machine	Install on machine	Remove from machine	N/A	N/A	Remove from machine	Install on machine
Tooling	Remove from machine	Remove from machine	Install into machine	Remove from machine	N/A	N/A	Remove from machine	Install on machine
Boot	Remove from machine	Remove from machine	Install into machine	Remove from machine	N/A	N/A	Remove from machine	Install on machine
Base Plate	Remove from machine	Remove from machine	Install on machine	Remove from machine	N/A	N/A	Remove from machine	Install on machine
Hopper	Remove from machine	Remove from machine	Install on machine	Remove from machine	N/A	N/A	Remove from machine	Install on machine
Top Cam area	Clean in machine	Clean in machine	Clean in machine	Clean in machine	Clean in machine	Clean in machine	Clean in machine	Clean in machine
Upper Drift Pin Assembly	Remove from machine	Remove from machine	Remove from machine	Remove from machine	Remove from machine	Remove from machine	Remove from machine	Remove from machine
Motor	Clean on machine	Clean in machine	Clean in machine	N/A	Clean on machine	Clean in machine	Clean on machine	Clean on machine
Upper Drift Pin Assembly Threaded Cam	Clean in machine	Clean in machine	Clean in machine	Clean in machine	Clean in machine	Clean in machine	Clean in machine	Clean in machine
Lower Drift Pin Assembly	Remove from machine	Remove from machine	Remove from machine	Remove from machine	Remove from machine	Remove from machine	Remove from machine	Remove from machine
Perspex Case	Clean on machine	Clean in machine	Clean on machine	Clean on machine	N/A	N/A	Clean in machine	Clean on machine
Base/Frame	Clean on machine	Clean in machine	Remove from machine	Remove from machine	N/A	N/A	Clean in machine	Clean on machine

Cleaning Level Key

Level 1 - Remove powder
Level 2 - Dry clean with cloth
Level 3 - Dry clean and re-lubricate if specified in lubrication schedule
Level 4 - Wet clean and re-lubricate if specified in lubrication schedule
Remove from machine - Take part out of machine and clean if required. Store it correctly or install back into machine.
Install into machine - Install part into the machine and make sure that it has been cleaned. If needed, lubricate to the level required.
Clean on/in machine - Clean the part while in the machine and do not remove it. Make sure that all contact surfaces are clean to the level required.

This cleaning matrix is intended as a guide only and is not an exhaustive list. All cleaning schedules will need to be adapted to the industry and product, following industry regulations and the material safety data sheets that come with specific products. Please check with your Food Safety Manager/Department, Quality Control Manager/Department, or other relevant internal departments at your company before using.

Storing the DTP 25®

After its thorough cleaning, the DTP 25® needs to be stored in the proper conditions. It is important to store it in an environment in which the machine is safe from rusting. The DTP 25®'s high traction areas and the Tooling need to be lubricated separately before you store them.

Tools and Materials Needed

- Plastic wrapping to cover machine
- Airtight container for Tooling (if in storage for more than a week)
- Lubricant/grease (food grade lubricant if machine has a high chance of contact with the food or drug product)
- Disposable latex/rubber gloves (for food grade products and to protect hands from lubricant)
- Hairnet and/or beard net (food grade products only)
- Sterile shoe covers (food grade products only)

Instructions

Note: Wear latex/rubber gloves (and appropriate food grade attire if applicable) during this process.

Lubricating the Tooling

If you are not using the machine for more than a week, store the Tooling in an airtight container and cover it with lubricant to prevent rust formation. If not, simply lubricate each part of the Tooling and reinsert it back into the machine.



LFA's TDP Tooling Case provides airtight storage and is perfect for transport and protection. Order at <https://www.lfatabletpresses.com/tooling-case-tdp>

1. Rub a finger's worth of grease on the Lower Assembly Timing Cam sides.

- 1.1 Note: Be sure to lubricate the Boot Timing Cam runner and the Lower Drift Pin Assembly Timing Rod runner.

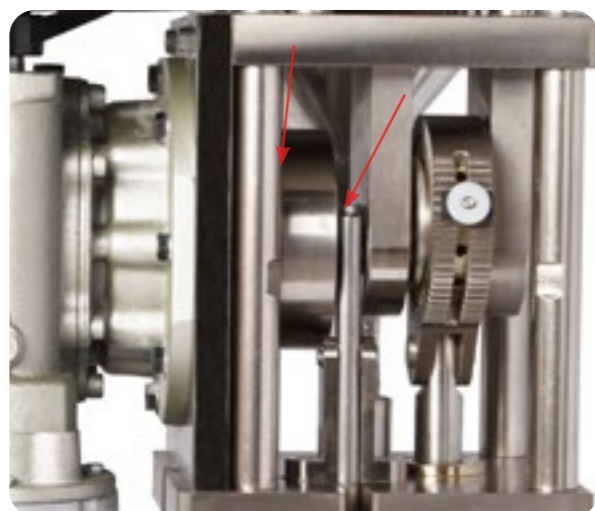

2. Apply grease between the Upper Drift Pin Assembly and DTP 25® base.



3. Apply grease between the Lower Drift Pin Assembly and Base Plate.



You can also lubricate any point of traction the DTP 25® at your own discretion; just be sure not to over-lubricate.

Cover the DTP 25®

4. Carefully cover the DTP 25® with the plastic wrapping.

- 4.1 Note: You can use the plastic wrapping that came with the machine in the shipping container.

Environmental Conditions

It is important that the environment in which you store the DTP 25® has the appropriate temperature and relative humidity levels. These two environmental factors can potentially cause the machine to rust and/or cause the tablets to have a lower quality. The table below shows the acceptable temperature and relative humidity levels:

Machine	Temperature		Humidity
	°C	°F	
DTP 25®	18-24	64-75	45-65% RH

Appendix

Glossary

Term	Definition
API/Active Pharmaceutical Ingredient	Any substance or mixture of substances used that is an active ingredient in the drug product.
Binding agent	See excipient.
Die	The part of the Tooling that makes up the hole in which the powder is compressed and shaped into a tablet.
Die bore	The cavity inside the middle of the Die.
Die face	The very top flat surface of the Die.
Ejection height	The height at which the Lower Punch is lifted to for a tablet's ejection from the machine.
Excipient	An inactive substance that serves as the vehicle or medium for a drug or other API.
Fill depth	The amount of space that the powder can flow into in the Die.
Formulation	Powder mix of the excipient and the API that is compressed to make tablets.
Granular material	See Formulation.
Kilonewton (kN)	The force to accelerate a mass of 1 kg at a constant 1 m per second. The TDP range's pressure is measured in this unit.
Punches	The Upper Punch and Lower Punch have concave endings in the shape of the desired tablet. When the punches meet, they compress the powder between.
Punch pressure	The adjustable amount of force that is used to press tablets.
TDP®	LFA trademarked term for desktop tablet press.
Tooling	Enables a tablet press to form tablets. It consists of a Die, Upper Punch, and Lower Punch.

Description of DTP 25® Parts

To order spare parts online, please go to <https://www.lfatabletpresses.com/products/pill-press-machine-spare-parts/dtp-parts>

Tooling

The Tooling consists of the Die, the Upper Punch, and the Lower Punch. This die set compresses the powder into the tablet. Order at <https://www.lfatabletpresses.com/tdp-tooling>

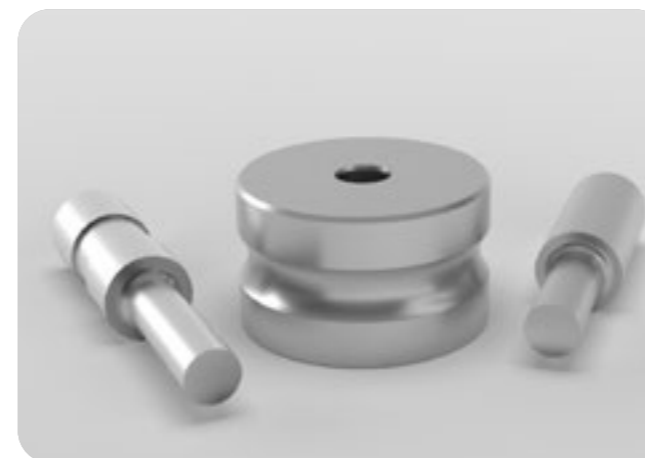

Lower Drift Pin Assembly Adjustment Plate

The Lower Drift Pin Assembly Adjustment Plates are used to adjust the tablet's fill depth and ejection height. They are located in the Lower Drift Pin Assembly.



Lower Assembly Timing Cam

The Lower Assembly Timing Cam moves the Lower Assembly Timing Rod, which raises the finished tablet out of the Die.



Hand Wheel

The Hand Wheel can be used to turn over the DTP 25® manually as well as with a de-jamming bar to turn over a stuck machine.



Boot

The Boot is where the dry granular materials are held for pressing. It fills the Die bore with the dry granular material and moves the finished tablet out of the Die before refilling it with the next batch of materials.



Boot Bolt and Spring

The Boot Bolt and Spring holds the Boot in place while the press is running and allows it to move back and forth. It is kept secure with a pin on top of the Boot.



Hopper

The Hopper is the funnel that holds the granular materials before it moves into the Boot to be pressed.



Lower Drift Pin Assembly Lifting Bar

The Lower Drift Pin Assembly Lifting Bar lifts the Lower Drift Pin Assembly that holds the Lower Punch and helps push the tablets out of the Die.



Upper Drift Pin Assembly

The Upper Drift Pin Assembly holds the Upper Punch in place.



Lower Drift Pin Assembly Timing Rod

The Lower Assembly Timing Rod raises the finished tablet out of the Die.



Eccentric Sheave Strap/Pressure Adjustment

The Eccentric Sheave Strap/Pressure Adjustment attaches the Upper Drift Pin Assembly to the Top Cam and also increases or decreases the Upper Punch pressure.



Lower Drift Pin Assembly

The Lower Drift Pin Assembly is located below the base of the tablet. It holds the Lower Punch in place in the Die while the Upper Punch pushes down to form the tablet in the middle.



Anti-Vibration Feet

The Anti-Vibration Feet are located on the machine's bottom four corners. They absorb noise and vibration produced by the machine.



Base Plate

The Base Plate is not only the mount for the Boot, but also holds the Die in place.



Top Cam Drive Shaft

All other DTP 25[®] parts are connected to the Top Cam Drive Shaft. As it is turned, all the parts of DTP 25[®] move.



Eccentric Sheave Inner Strap

The Eccentric Sheave Inner Strap attaches the Upper Drift Pin Assembly to the Top Cam Drive Shaft.



Upper Drift Pin Assembly Bushing Retainer

The Upper Drift Pin Assembly Bushing Retainer reduces friction between the Upper Drift Pin Assembly and upper platform of the machine.



Lower Drift Pin Assembly Bushing Retainer

The Lower Drift Pin Assembly Bushing Retainer reduces friction between the Lower Drift Pin Assembly and the Base Plate.



Boot Teflon Pad

The Boot Teflon Pad acts as a buffer between the Boot and the Base Plate.



List of Electrical Components

Name of Part	Part Manufacturer	Part Serial Number	Quantity	Link to Manufacturer's Site
VFD	Delta	VFD-11AMS21ANSAA	1	Delta
Terminal	Wago	2002-1201	7	Wago
Terminal	Wago	2002-1401	9	Wago
Ground Terminal Block	Wago	2002-1207	8	Wago
Variable Speed Dial	Guanghua Electronic Mall/Dunhua Electronic Materials Co., Ltd.	VR10T-001	1	Guanghua Electronic Mall/Dunhua Electronic Materials Co., Ltd.
Potentiometer	TOCOS	RV24YN-20S-B103	1	TOCOS
Variable Speed Dial Plate	Guanghua Electronic Mall/Dunhua Electronic Materials Co., Ltd.	VR10T-001L	1	Guanghua Electronic Mall/Dunhua Electronic Materials Co., Ltd.
Fuse Socket with Light	Shan Ho	SFKN-1 AC110~220V	2	Shan Ho
Fuse	Eaton	C10G2(10*38 2A)	2	Eaton
Circuit Breaker	Fuji Electric	BC62E0C-020	2	Fuji Electric
3 Phase AC Socket	Guanghua Electronic Mall/Dunhua Electronic Materials Co., Ltd.	9336	1	Guanghua Electronic Mall/Dunhua Electronic Materials Co., Ltd.
Power Switch	Shan Ho	SC-88-3P	1	Shan Ho
Emergency Stop	Rockwell Automation	800FM-MT44/ALM/X02	1	Rockwell Automation
Stop Button	Rockwell Automation	800FM-LF4MN3RX10/AB7	1	Rockwell Automation
Run Button	Rockwell Automation	800FM-LF3MN3GX10/AB7	1	Rockwell Automation
Contactors	Fuji Electric	SC-03/G DC24V 1A-CCC	1	Fuji Electric
Thermal Overload Relay	Fuji Electric	TR-0N/3 6A-CCC	1	Fuji Electric
Waterproof Cable Gland	AVC	MG20A-10 ST-AA	1	AVC
Cable Gland	AVC	MGB10-03B-ST	1	AVC
Interlock Safety Switch	Rockwell Automation	440G-T27256	1	Rockwell Automation
Relay with Light	Omron	MY4N-GS DC24 BY OMZ	1	Omron
Relay	Omron	PYF14A-E BY OMZ	1	Omron
Power Supply	Omron	S8VK-S12024	1	Omron
Fan	Sunon	PMD2412PMB1-A P/N:(2) GN	1	Sunon
Fan Guard	Sunon	FG-12	1	Sunon
Power Cable for Fan	Sunon	4" for A2-20 2M	1	Sunon
Terminal Plate for Ground	Rong Kuang Electric Co., Ltd.	WJ9005 (5P)	1	Rong Kuang Electric Co., Ltd.
Interlock Safety Switch Pin	Rockwell Automation	440G-A27011	1	Rockwell Automation

Material of Contact Parts

Contact Part	Material
Boot	304 SS+PTFE
Die Seat Table	304 SS
Tooling (Upper Punch, Lower Punch, and Die)	User specified
Ejection Tray	304 SS
Hopper	304 SS

Technical Specifications

Number of dies	1
Max production capacity	1,500/hour
Max diameter of tablet	25 mm
Max thickness of tablet	8 mm
Max fill depth	20 mm
Max pressure	100 kN
Number of filling stations	1
Double layered tablet	No
Power USA	220 V 1 phase 2.2 kW 60 Hz
Power UK	240 V 1 phase 2.2 kW 50 Hz
Overall size	710 mm x 620 mm x 1340 mm
Dimensions with suggested working clearance	1610 mm x 1520 mm x 2240 mm
Weight	332 kg (731.9 lbs)

Maintenance Checklist

Before Operation	
<input type="checkbox"/>	Visually inspect the tablet press and the parts.
<input type="checkbox"/>	Ensure all bolts and screws are tight.
<input type="checkbox"/>	Visually inspect lubrication points and regrease where necessary.
<input type="checkbox"/>	Tune the tablet press by hand to get the tablet size and weight correct.
<input type="checkbox"/>	Manually operate the machine for at least two full rotations to ensure it is not jammed.
During Operation	
<input type="checkbox"/>	Listen for irregular knocking or clicking sounds. If heard, stop operation and lubricate the desktop press.
<input type="checkbox"/>	Watch for buildup of powder in front of the Boot. If occurring, either (a) make mix more granular, (b) check the Boot's base for damage, or (c) clear the buildup with a paintbrush.
<input type="checkbox"/>	Occasionally check the Motor's temperature. If it starts to overheat, turn off the machine, let it cool down, and grease it to ensure smooth operation.
<input type="checkbox"/>	Ensure that the Hopper does not run out of powder.
<input type="checkbox"/>	Weigh a sample tablet and test for its hardness.
After Operation	
<input type="checkbox"/>	Unplug machine and remove all excess powder with a bagless vacuum.
<input type="checkbox"/>	Remove the Boot and the Tooling and clean the inside of the tablet press.
<input type="checkbox"/>	Wipe down the other surfaces with a damp cloth.
<input type="checkbox"/>	Apply a layer of food grade grease to the entire desktop tablet press.
<input type="checkbox"/>	Lubricate high-traction points.
<input type="checkbox"/>	Store Tooling in an airtight box with a small amount of grease.

Diagrams

DTP 25[®] Dimensions Diagram

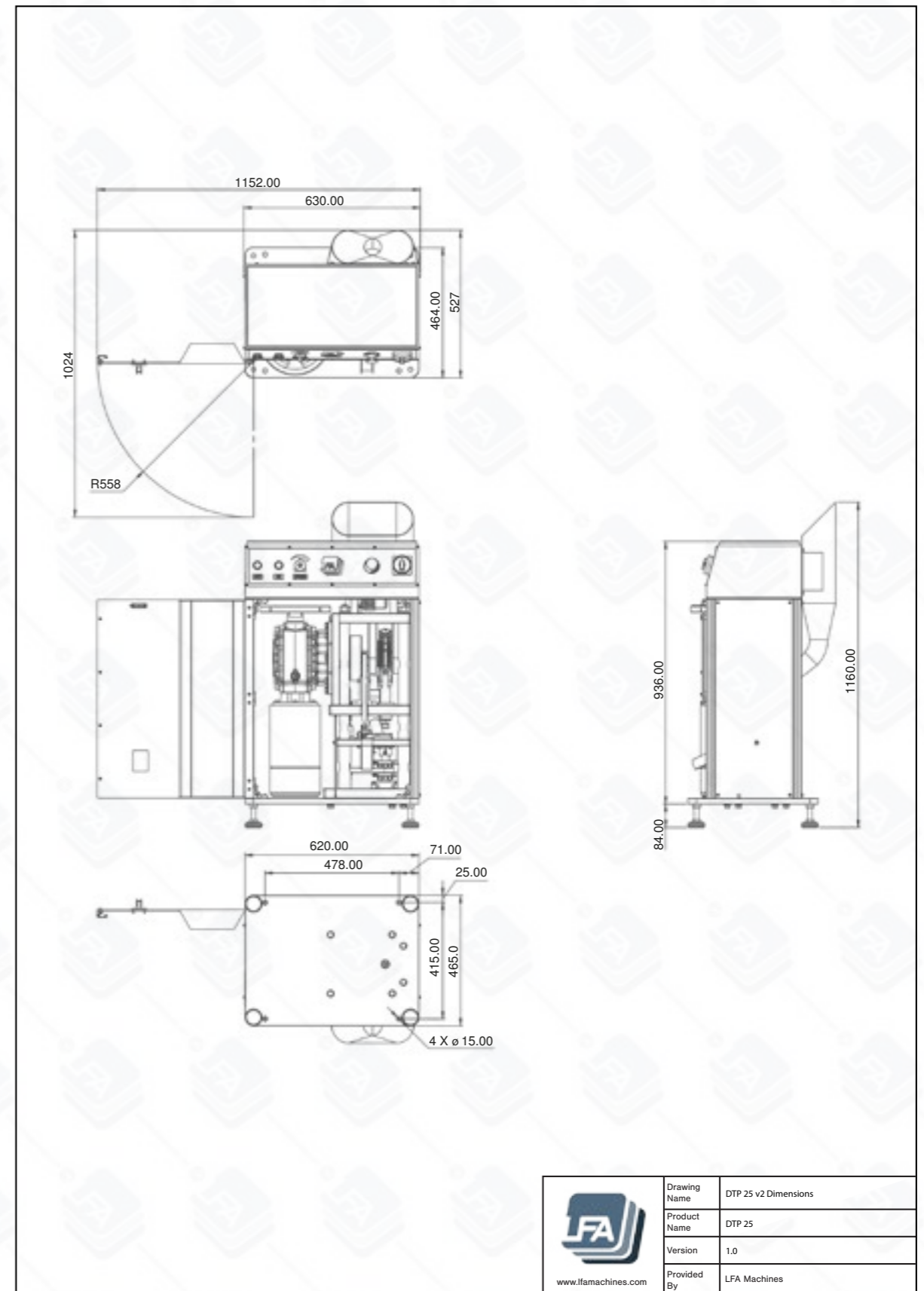

TDP® International Tooling
Standard Dimensions

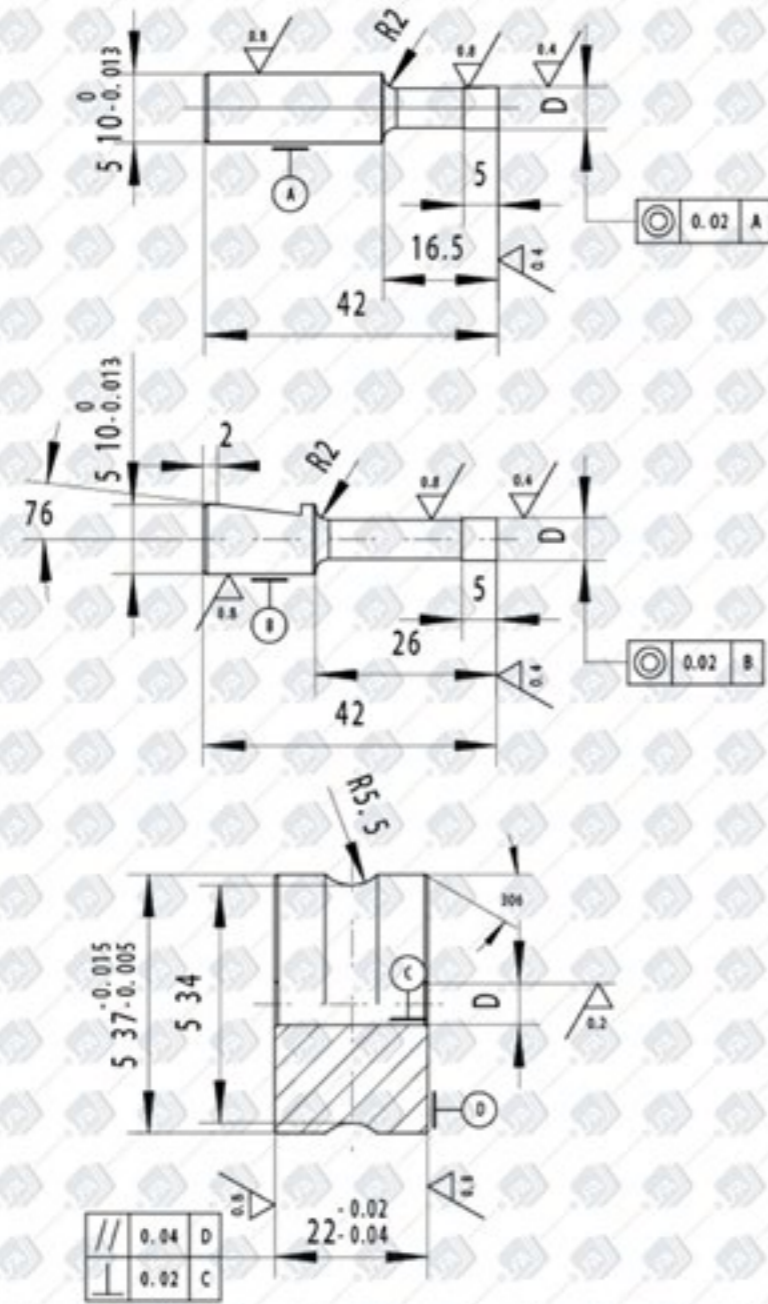

www.lfatabletpresses.com

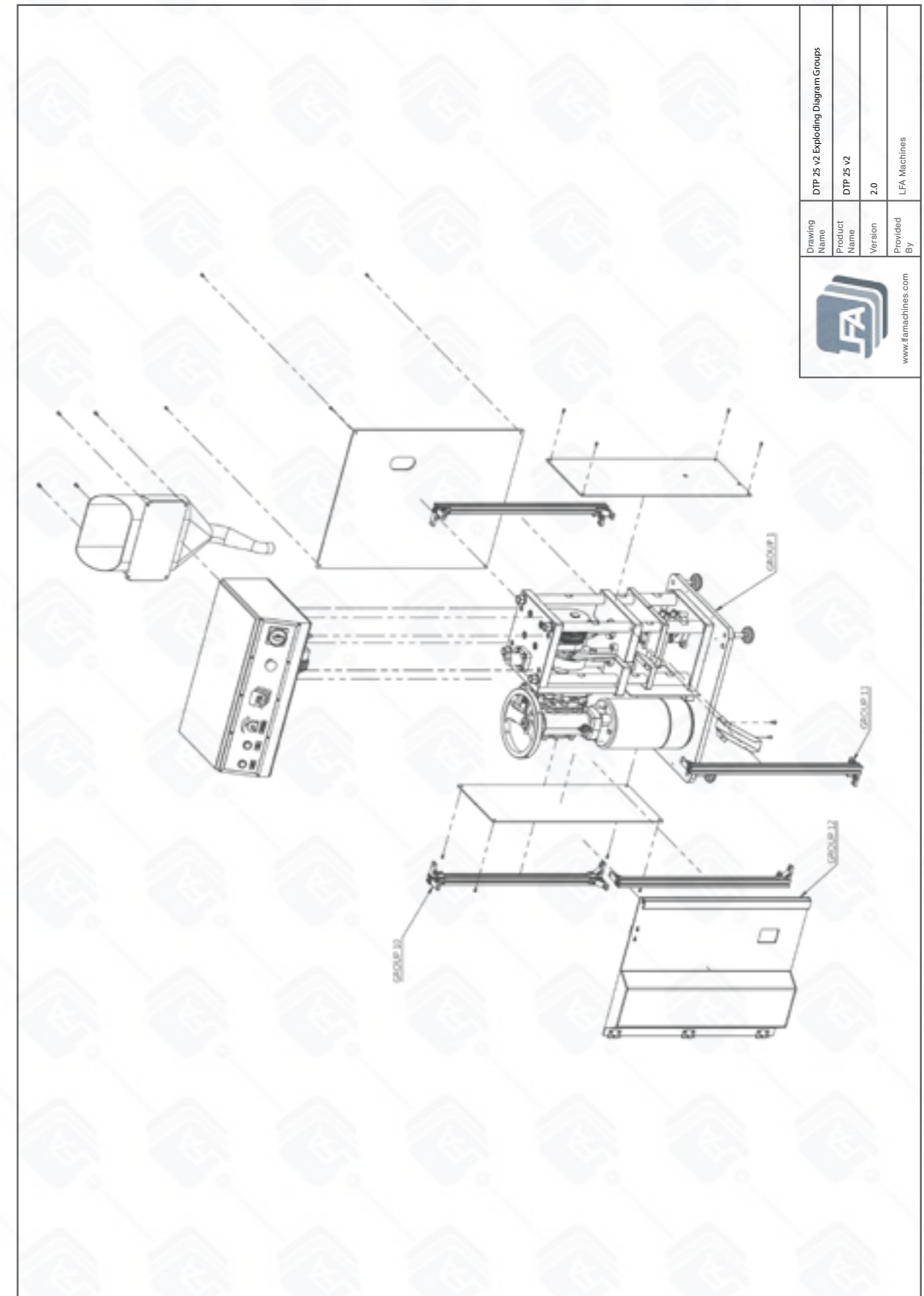

Drawing Name	DTP 25 v2 Exploding Diagram Groups
Product Name	DTP 25 v2
Version	2.0
Provided By	LFA Machines



DTP 25® Exploding Diagram Group 1

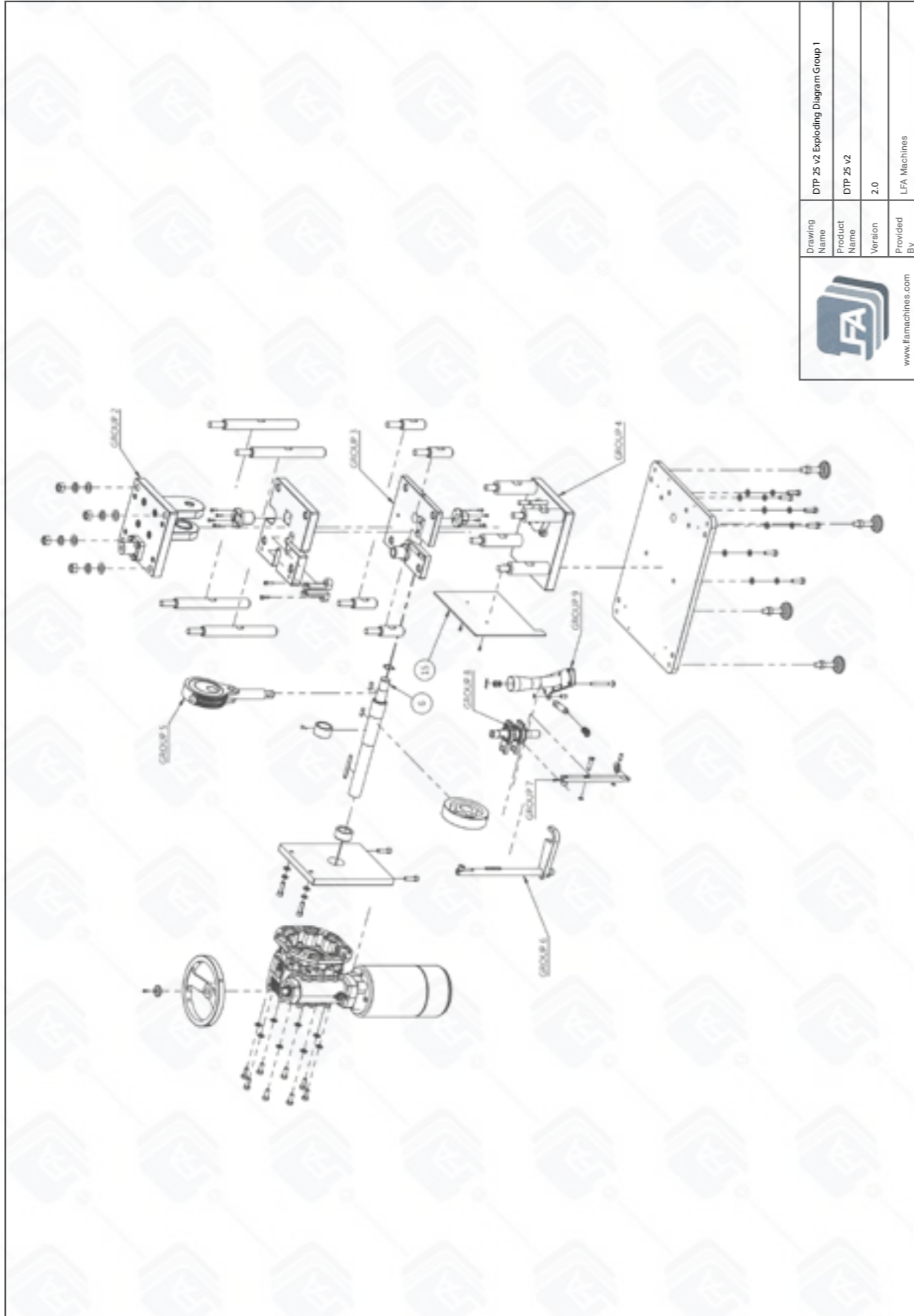

DTP 25® Exploding Diagram Group 2

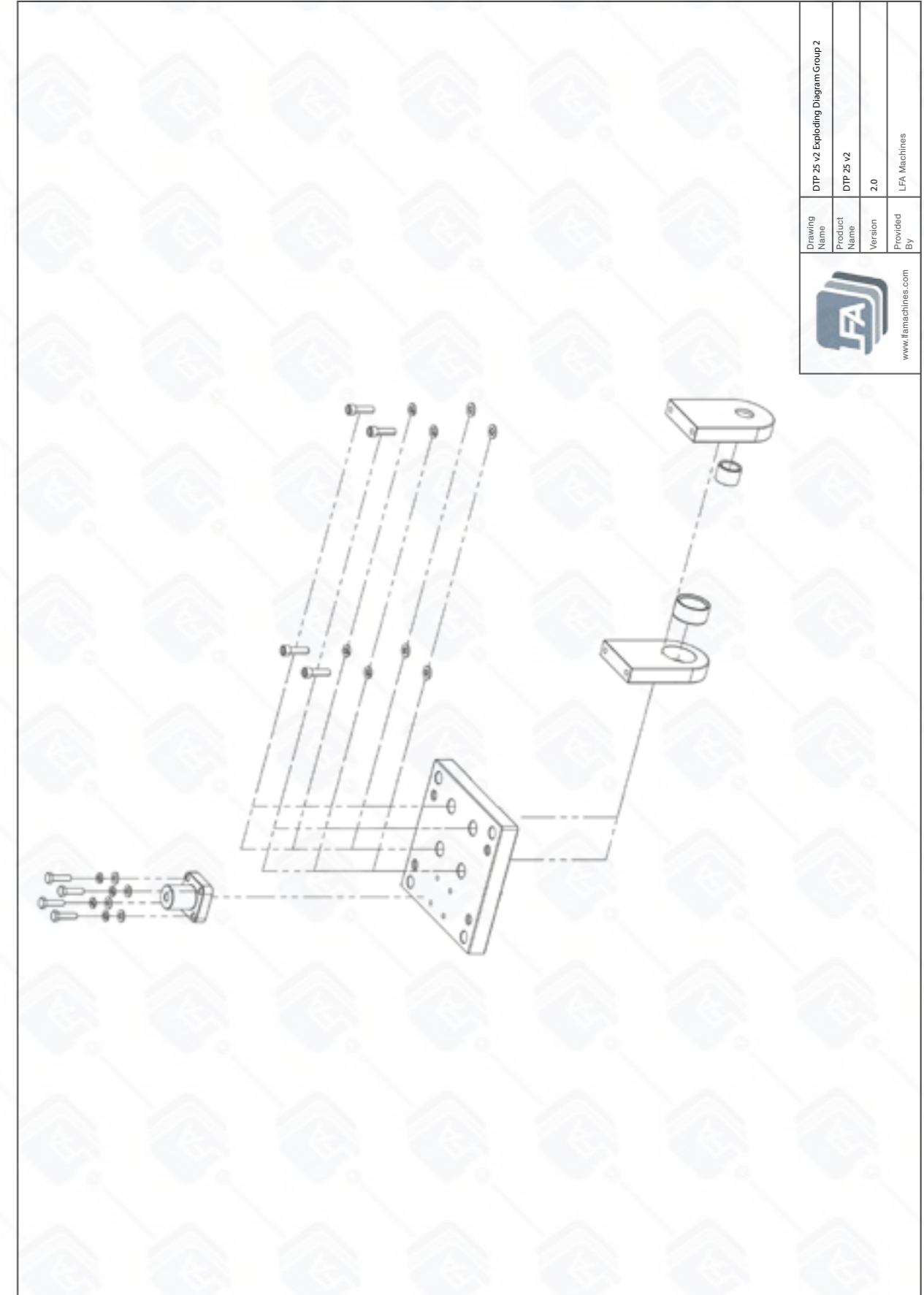

DTP 25® Exploding Diagram Group 3

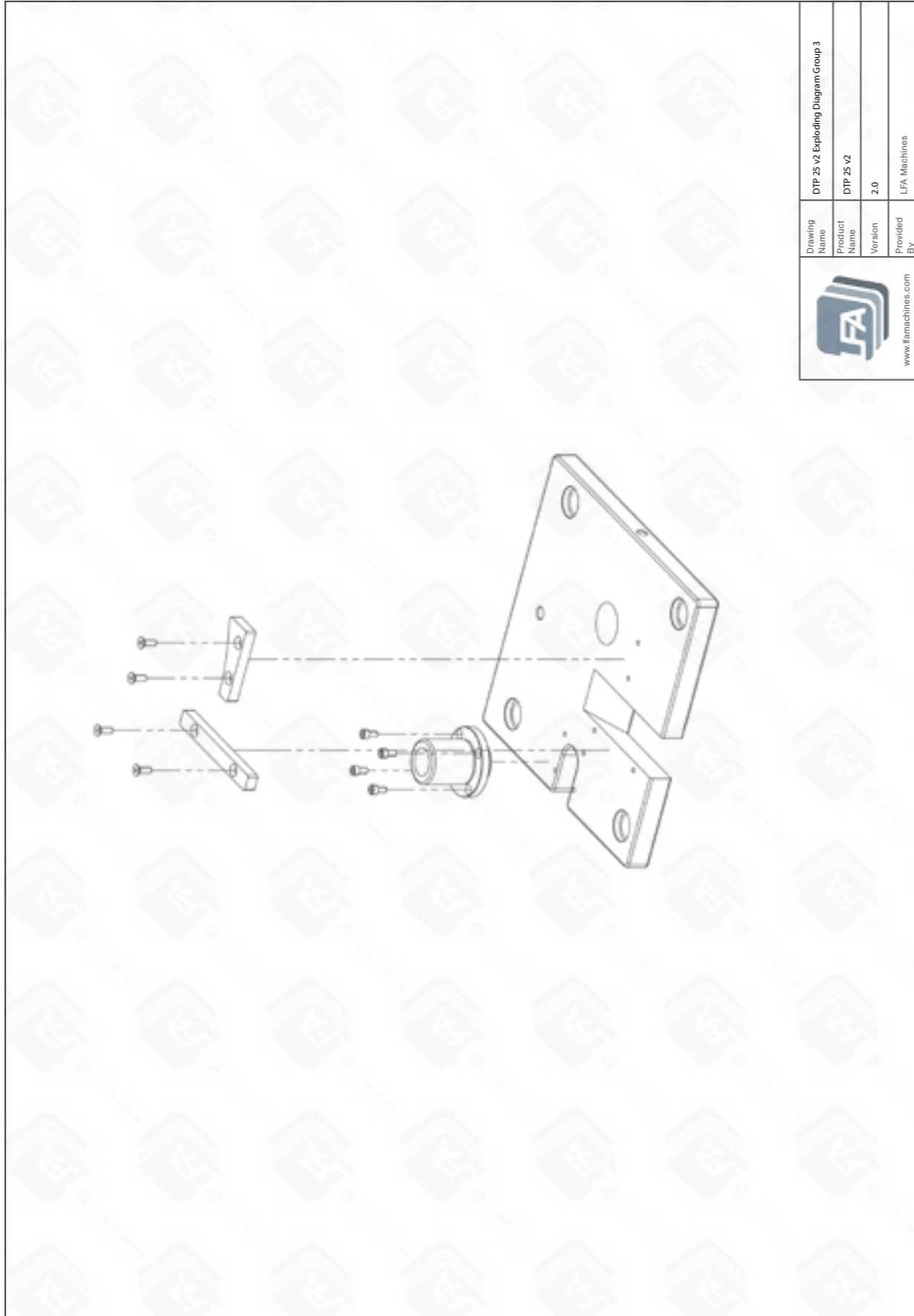

DTP 25® Exploding Diagram Group 4

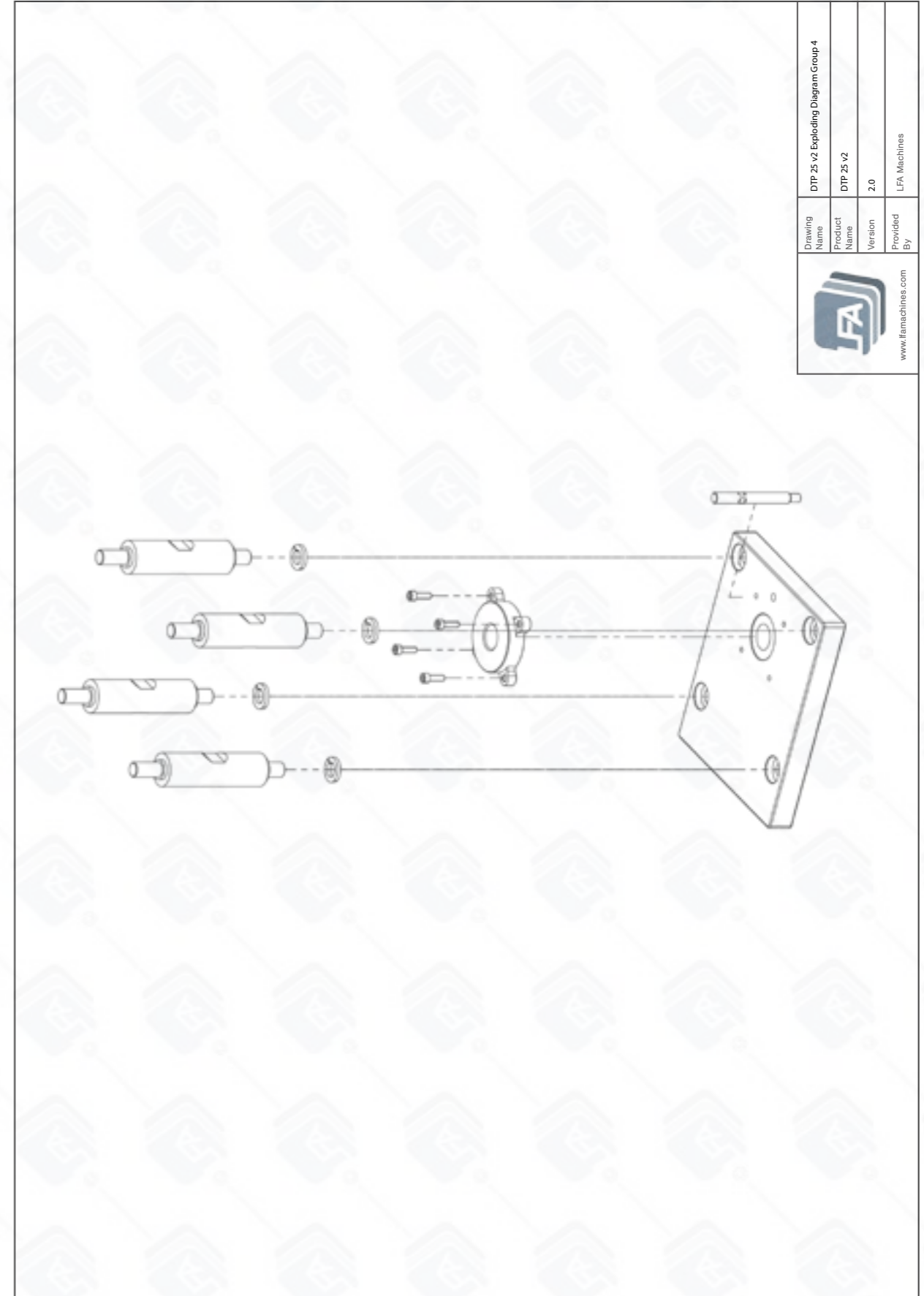

DTP 25® Exploding Diagram Group 5

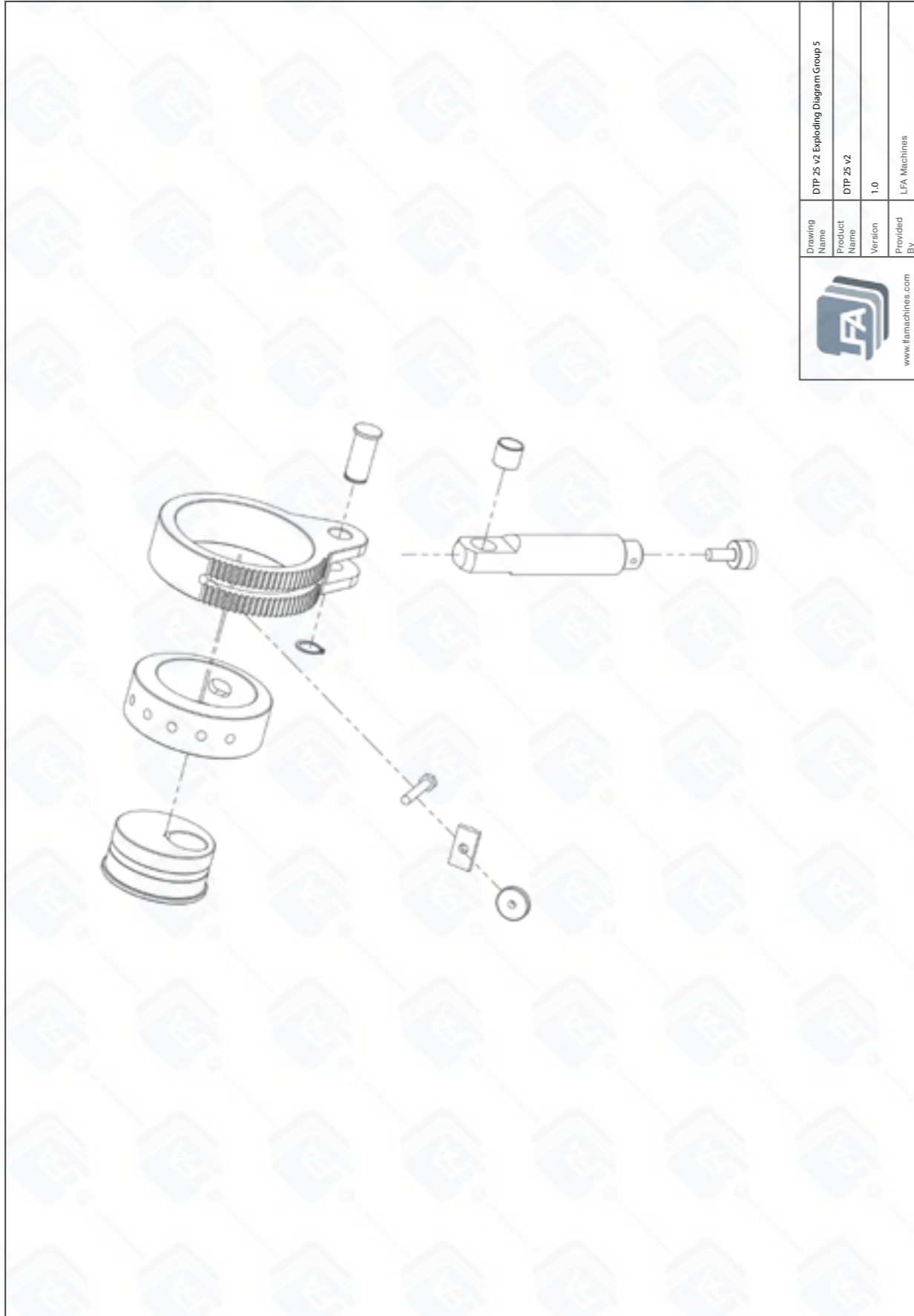

DTP 25® Exploding Diagram Group 6

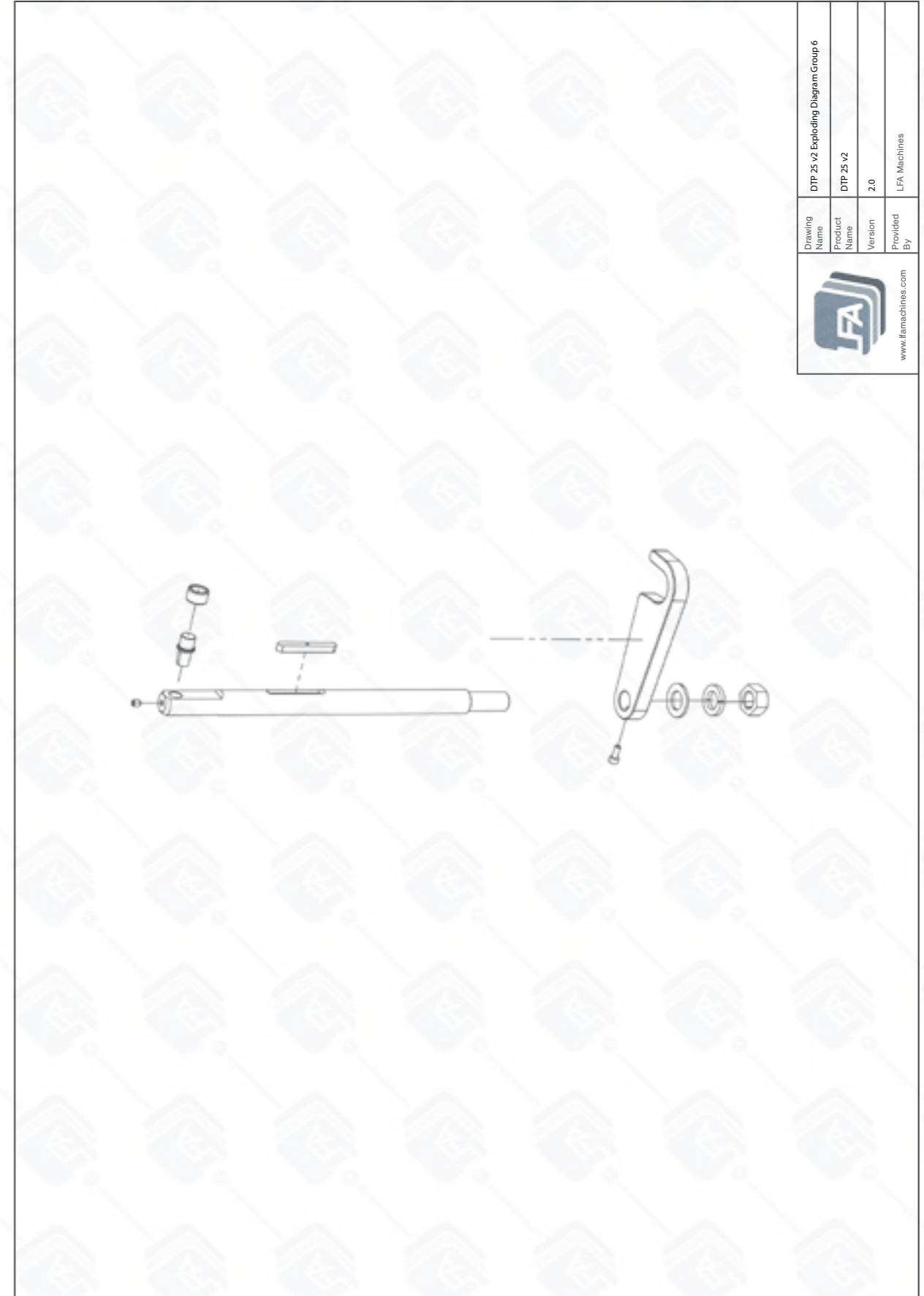

DTP 25® Exploding Diagram Group 7

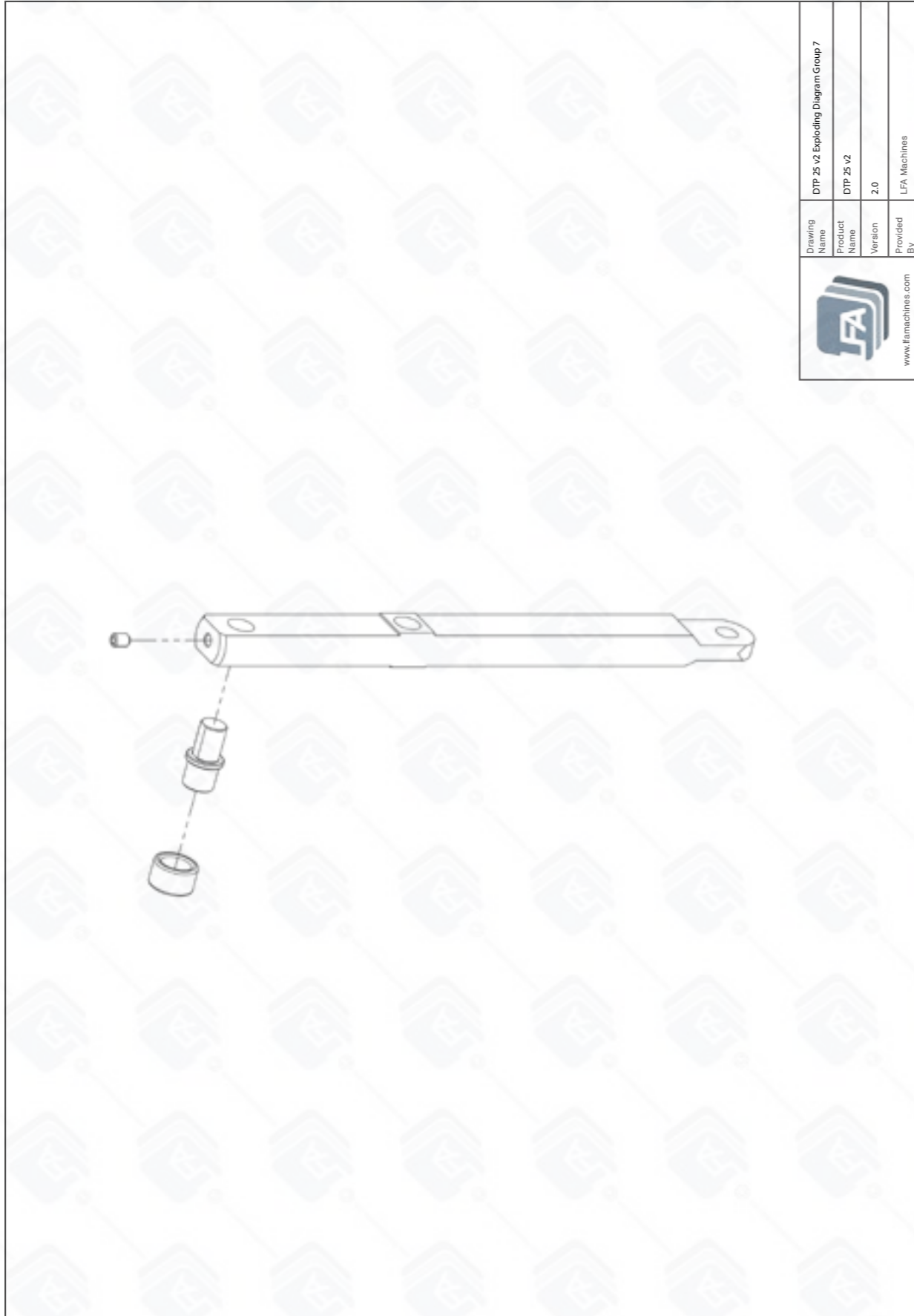

DTP 25® Exploding Diagram Group 8

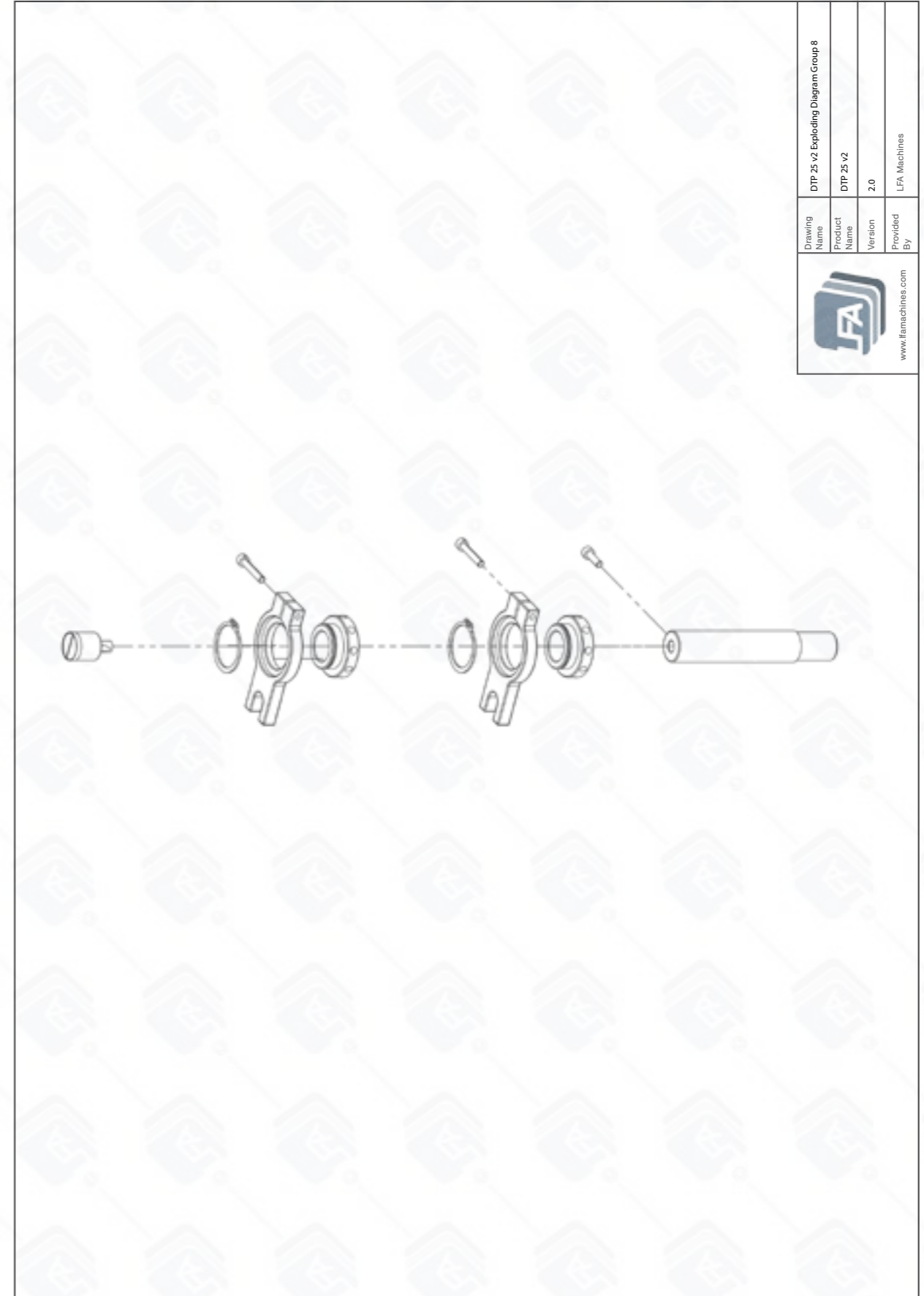

DTP 25® Exploding Diagram Group 9

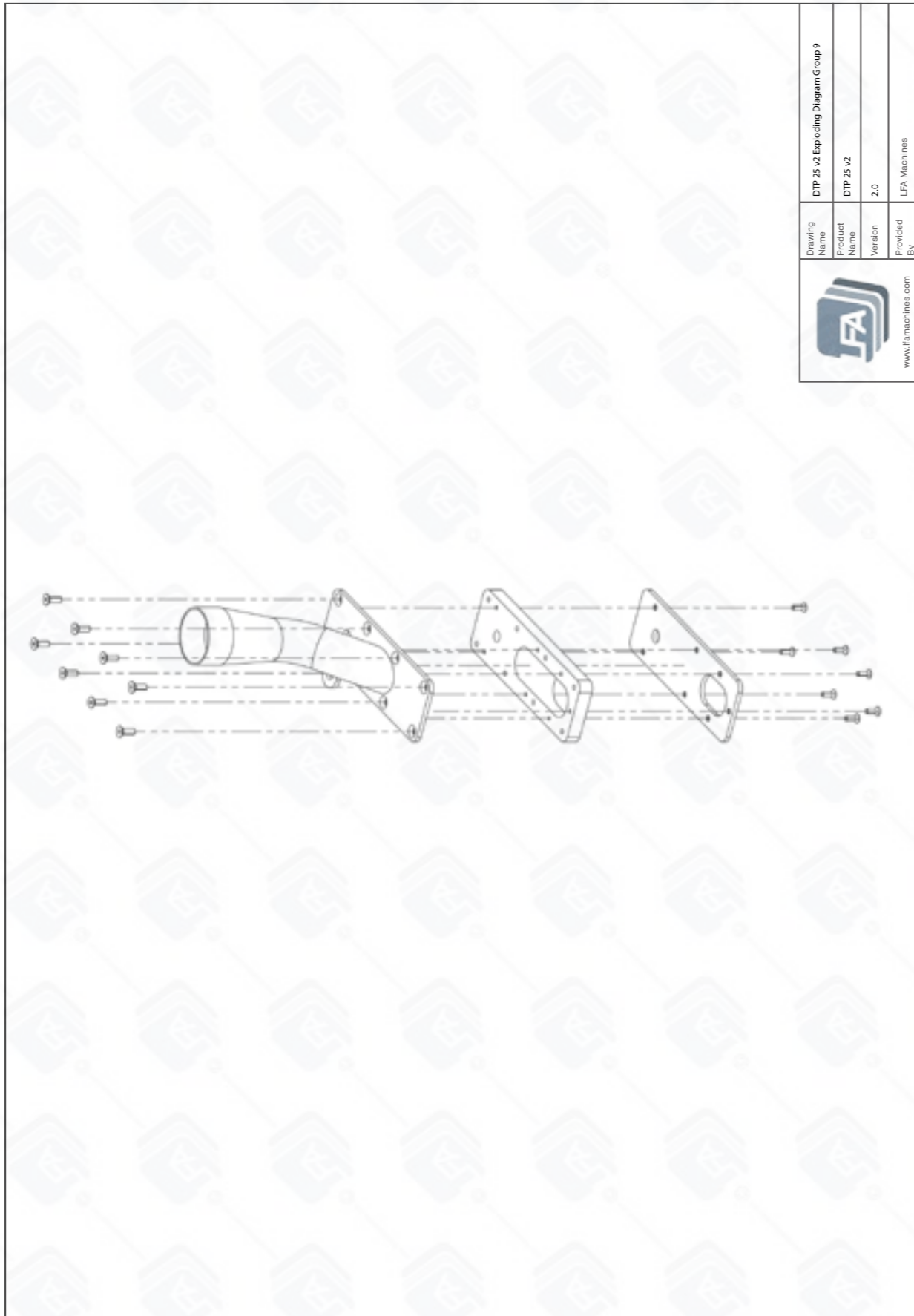

DTP 25® Exploding Diagram Group 10

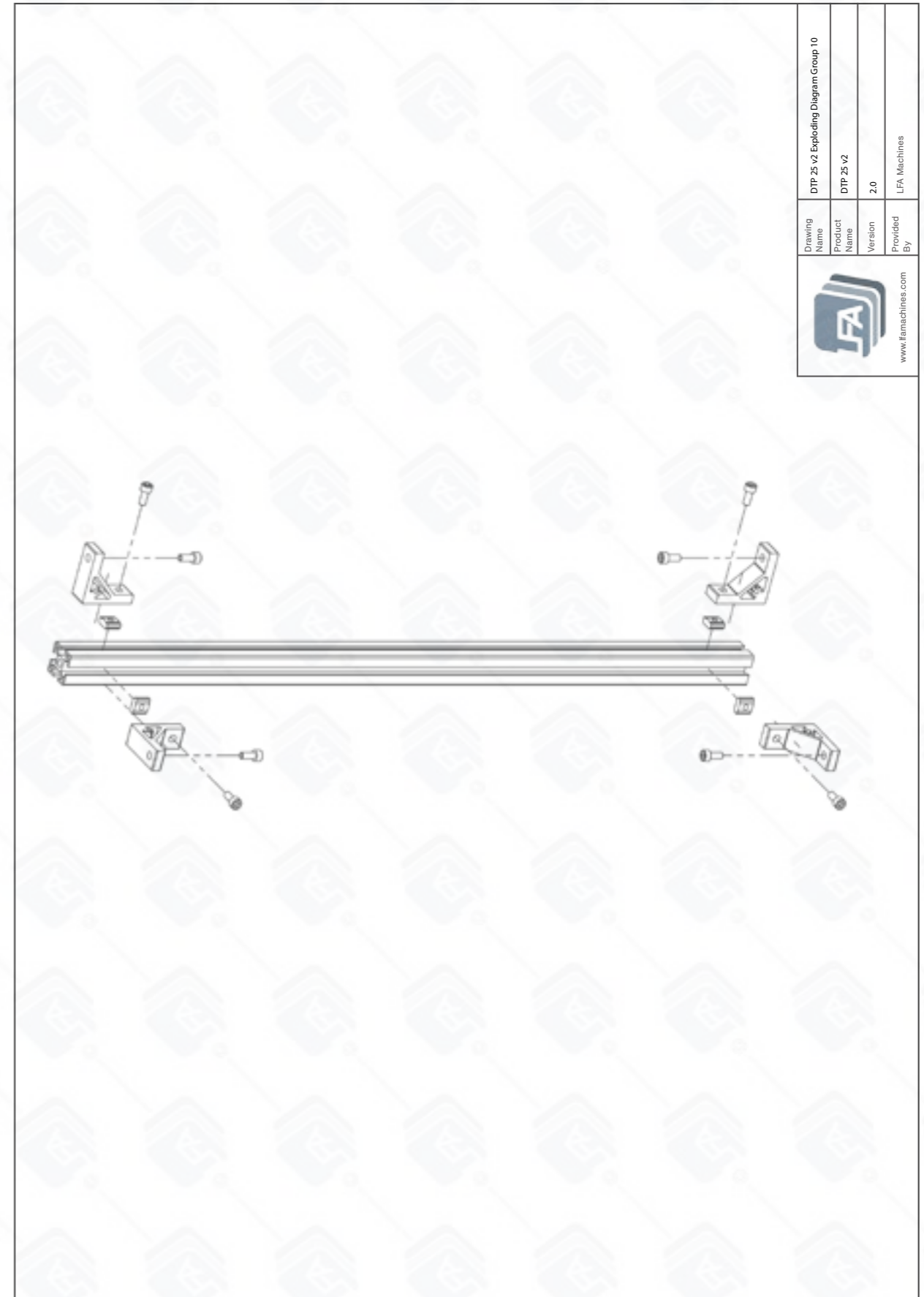

DTP 25® Exploding Diagram Group 11

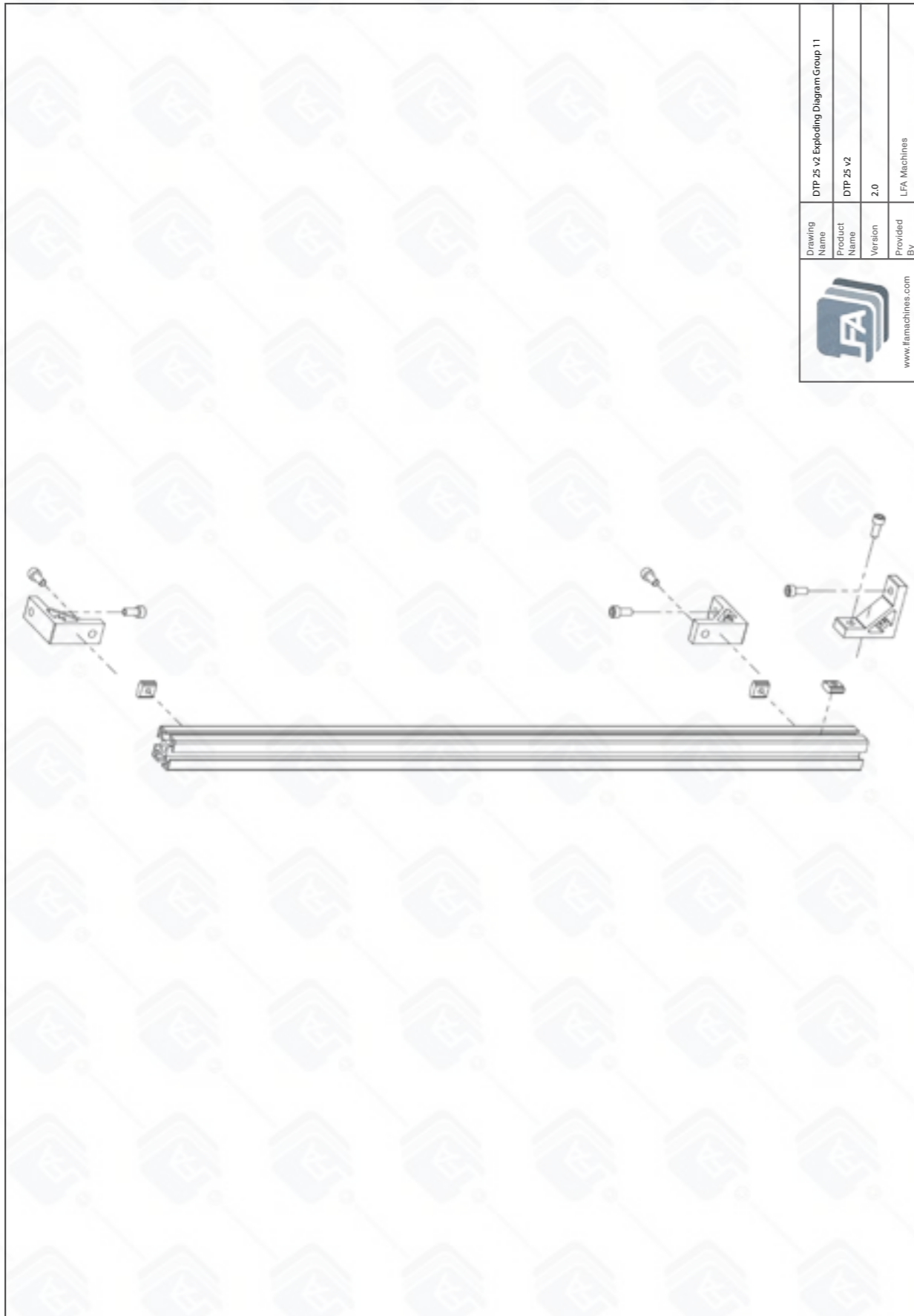

DTP 25® Exploding Diagram Group 12

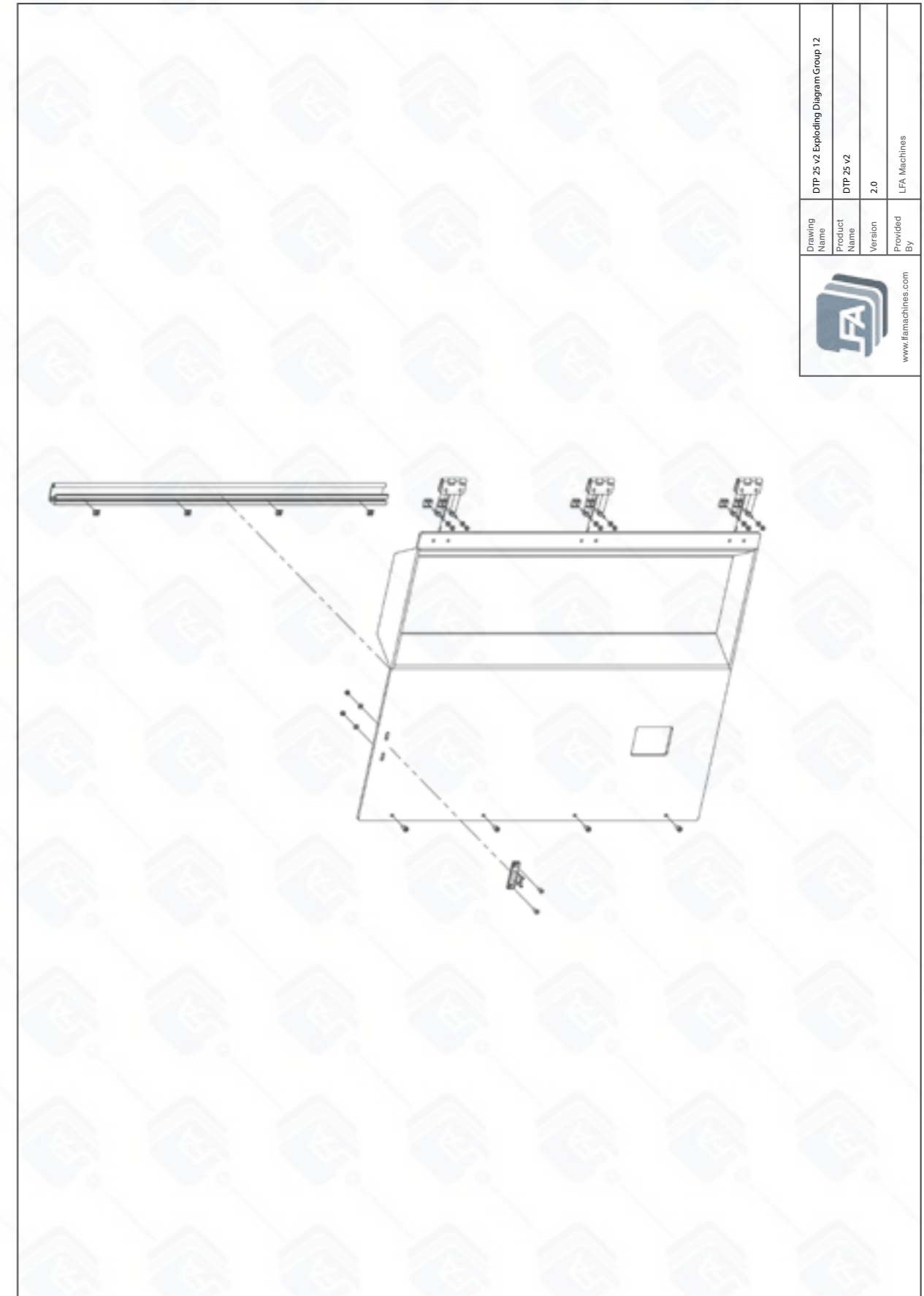

DTP 25® Wiring Diagram 1

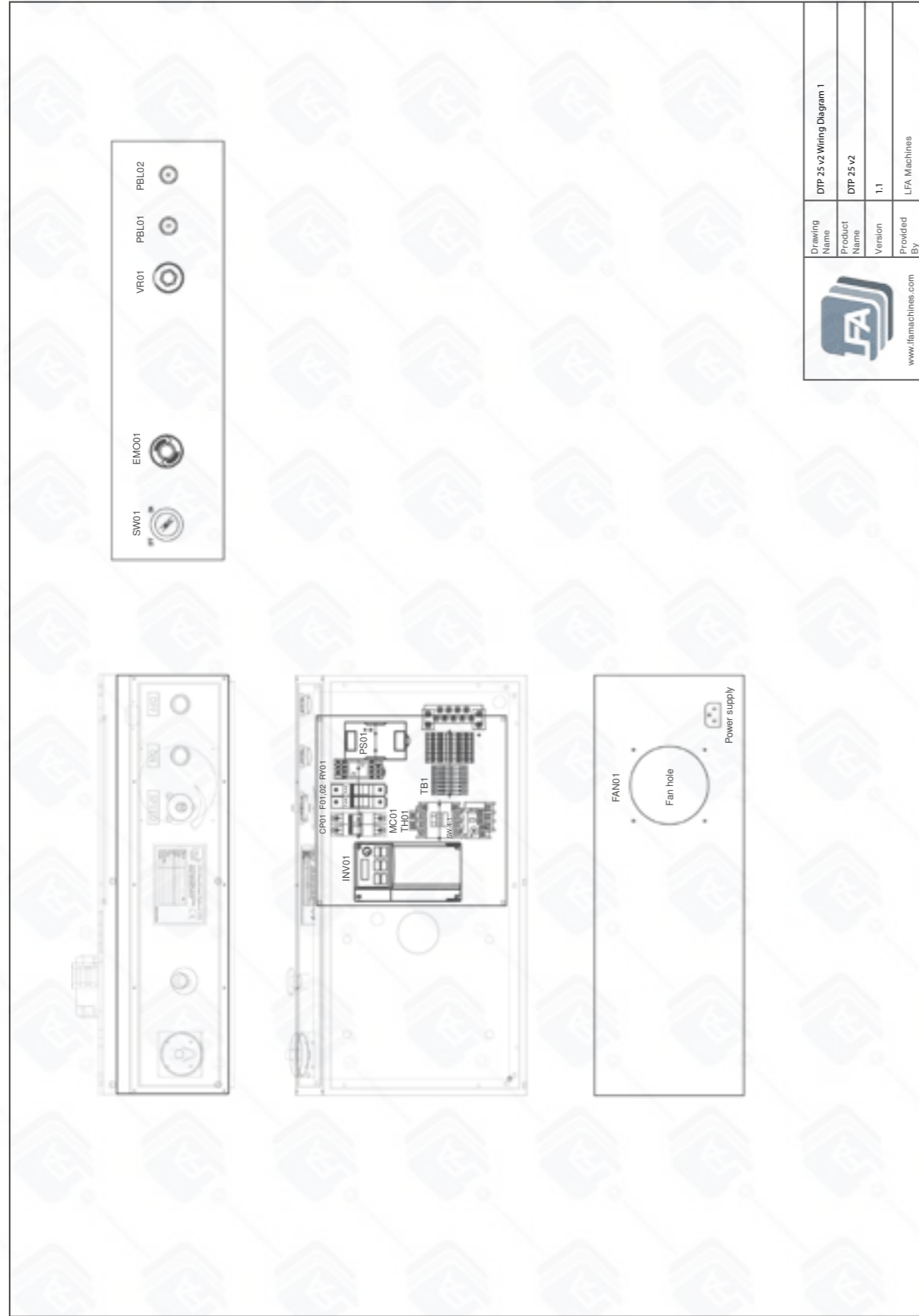

DTP 25® Wiring Diagram 2

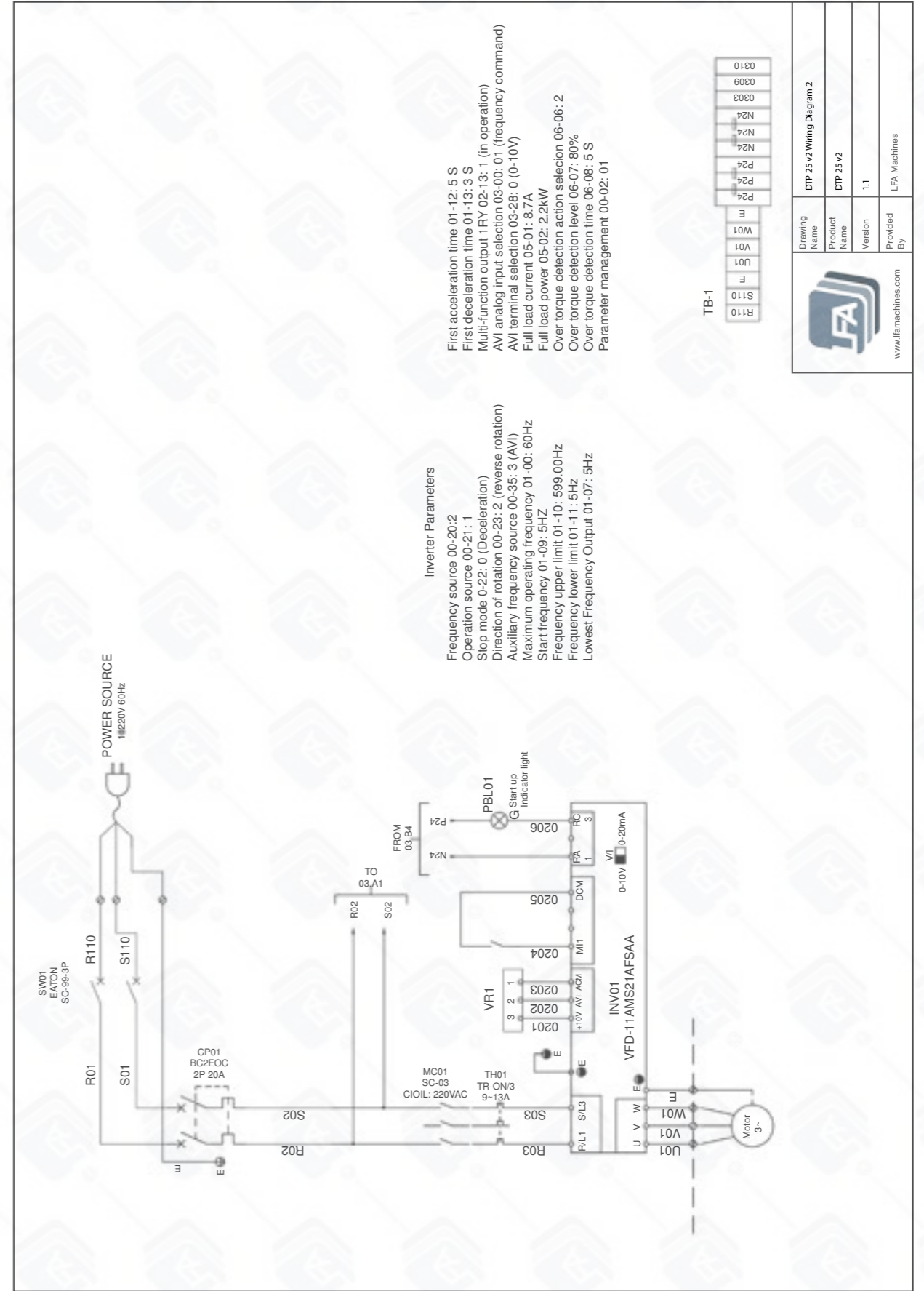

DTP 25® Wiring Diagram 3

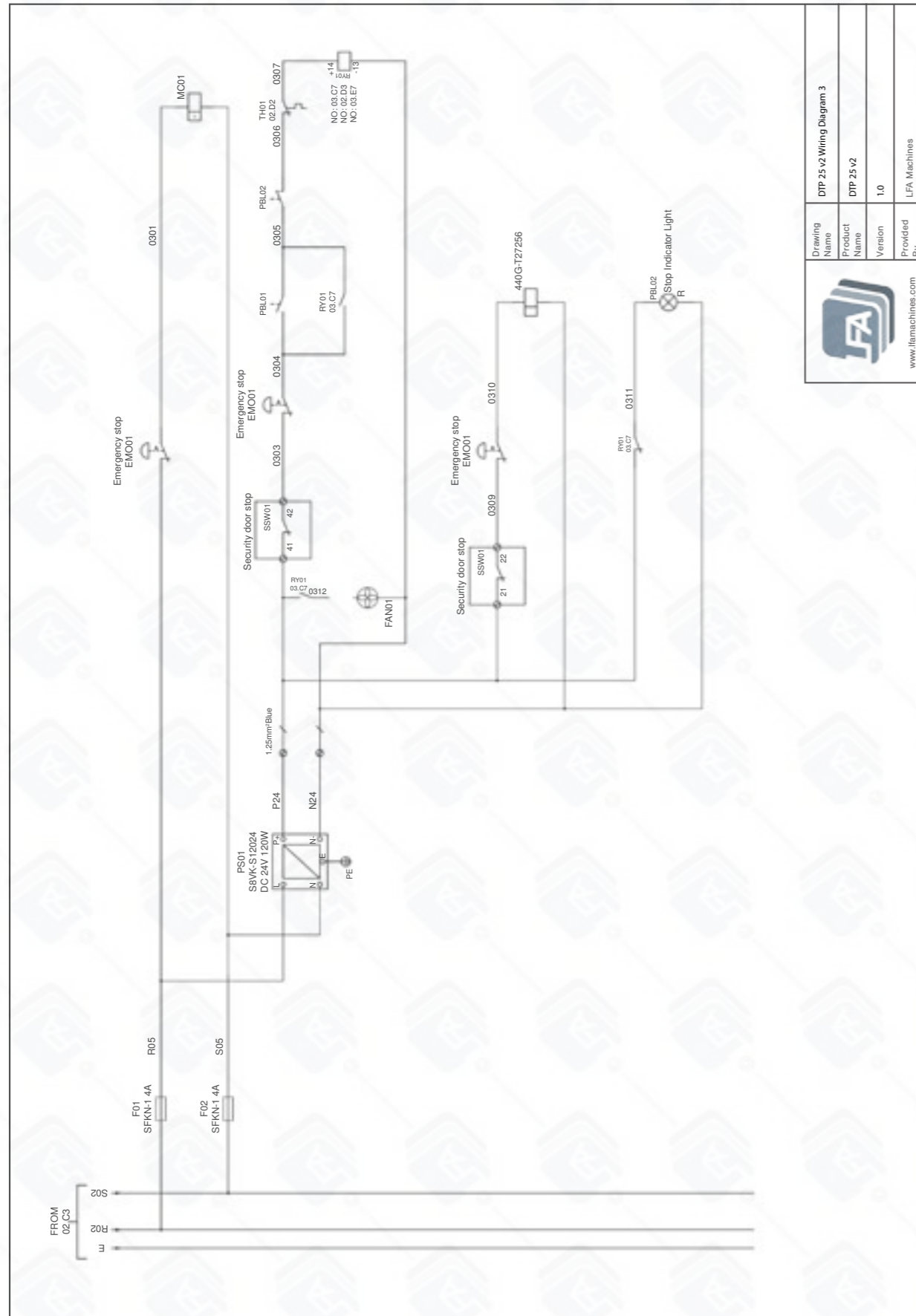

Resources

Helpful Links

Warranty

For information regarding the warranty policy of the DTP 25® and other LFA products, please visit <https://www.lfatabletpresses.com/warranty>

LFA Website

In order to aid you in your tablet production, LFA Machines maintains a website that offers a breadth of useful information about the DTP 25® and other tablet presses. Use our online tools such as the Tablet Mix Calculator to help you in your formulation production or read our regularly published articles that cover a whole range of topics about tablet presses and tablet production.

Visit the LFA homepage at <https://www.lfatabletpresses.com>

LFA Machines YouTube Channel

Our YouTube videos provide you an opportunity to see how to use our tablet presses, common troubleshooting tips, and other LFA products such as capsule fillers and mixers. We regularly upload videos to give you a visual aid that will hopefully support you in your tablet production efforts. To watch our videos, visit <https://www.youtube.com/channel/UCwtbcwja77ai7vX2o34FUkQ>

LFA Machines Social Media

Social media is a great way to keep yourself updated on new developments and exciting things happening at LFA Machines. The list below contains our current social media pages:

Twitter: @lfatabletpress

Instagram: @lfatabletpresses

Facebook: <https://www.facebook.com/lfatabletpresses>

LinkedIn: <https://www.linkedin.com/company/lfa-machines-oxford-ltd/>

Contact Us

UK

LFA Machines Oxford Ltd
Unit 4B Rowood Estate
Murdock Road
Bicester, Oxfordshire OX26 4PP
+44 (0) 1869 250 234
support.uk@lfamachines.com
Monday-Friday
9AM-5PM GMT

US

LFA Machines DFW, LLC
6601 Will Rogers Blvd
Fort Worth, TX 76140
+1 (682) 312 0034
support.usa@lfamachines.com
Monday-Friday
8AM-6PM UTC (Central)

Germany

LFA Machines Düsseldorf GmbH
Business Parc Am Trippelsberg 92
Düsseldorf, North-Rhine
Westphalia 40589
+41 21188250223
verkauf@lfamachines.com

Taiwan

LFA Machines Taiwan Ltd
7F-5, No. 2, Sec. 2 Taiwan Blvd
West District, Taichung City 403
Taiwan
+886 2773 74704
support.asia@lfamachines.com



LFA MACHINES

Copyright © 2024 by LFA Machines

www.lfamachines.com

United Kingdom

Unit 4B
Murdock Road
Bicester
Oxfordshire
United Kingdom
OX26 4PP

United States

6601 Will Rogers Blvd
Fort Worth
Texas
United States
76140

Germany

Business Parc Am
Trippelsberg 92
Düsseldorf
Germany
40589

Taiwan

7F.-5, No. 2, Sec. 2
Taiwan Blvd., West Dist.,
Taichung City 403,
Taiwan