



HSTP[®] Range Tablet Press User Manual



We don't just sell machines—
we provide service.

Copyright Notice

© LFA Machines Oxford Limited, published in 2021 by LFA Machines Oxford Limited 2021. Registered in England and Wales, company number 08428898, registered office for service Demar House 14 Church Road East Wittering, Chichester, West Sussex, PO20 8PS.

All rights reserved. No part of this publication may be reproduced or transmitted, in any form or by any means, or stored in any retrieval system of any nature, without prior permission, except for fair dealing under the Copyright, Designs and Patents Act 1988, or in accordance with the terms of license issued by the Copyright Licensing Agency in respect of photocopying and/or reprographic reproduction. Application for permission for other use of the copyright material including permission to reproduce extracts in other published works shall be made to the publisher. Full acknowledgment of author, publisher and source must be given.

All trade marks are acknowledged and are owned by their respective owners.

Important Safety Information

READ THIS BEFORE OPERATING MACHINE

Intended Use

The intended use of this machine is to press dry raw materials into tablet form.

Potential misuse of this machine includes:

- Applying too much force to the powder.
- Trying to fill the Die with powder by hand.
- Inserting Tooling that is too big for the machine.
- Using powders that could explode under pressure.
- Using powders with extremely small particles (≥ 100 mesh).
- Using wet or damp material.

Personal Protection

For personal protection while transporting the HSTP[®], abide by these actions:

- Use an forklift to raise the machine.
- Wear steel toe boots to prevent foot injury.
- Wear heavy duty grip gloves to ensure firm grasp on machine.
- Wear back support belt to prevent injury if needed.

For personal protection while operating the HSTP[®], abide by these actions:

- Avoid wearing loose jewelry to prevent machine entanglement.
- Contain long hair to prevent machine entanglement.
- Wear safety goggles.
- Wear disposable latex/rubber gloves.
- Wear a hairnet (food grade products only).
- Wear a beard net if needed (food grade products only).

General Hazards

- Be aware of risk of entanglement and pinch point due to moving parts.
- Do not operate in a wet environment or with wet hands due to risk of electrical shock or burn.
- Do not operate if any wires are damaged, pinched, or frayed due to risk of electrical shock or burn.
- Keep out of reach of children.
- Keep fingers away from all moving parts.
- Ensure that it is secured to a workbench to prevent from falling.
- Inspect machine before use.
- Check that nuts and bolts are suitably tightened.
- Use this machine only for its intended use as described in this manual.
- Turn off and unplug the machine before conducting cleaning and maintenance.
- Do not modify the machine in any way.

Safety Assessment

It is critical to conduct a safety assessment to ensure that it complies with all local laws and industry accepted safety regulations.

If you require guidance on the installation of the machine or conducting a safety assessment, please contact LFA Machines.

Important Safety Information

READ THIS BEFORE OPERATING MACHINE

Symbols



WARNING

This signals potential risk for personal injury.



WARNING

This signals potential risk for electrical shock.



CAUTION

This signals potential risk for damage to the machine or other parts.

Modes for Stopping

In the case of an emergency during operation, immediately push the Emergency Stop/turn the Isolator Switch (see below) and unplug.



Prop. 65 Statement for CA Residents

Based on LFA's current level of knowledge of our machines, the HSTP® range does not require a Proposition 65 warning label.

Warning for Explosive Material

This machine is not explosion proof. LFA recommends that you test your materials' explosivity before running them through this machine. If your materials are indeed explosive, do not use them with this machine.

Table of Contents

Copyright Notice	2
Important Safety Information	3
Intended Use	3
Personal Protection	3
General Hazards	3
Safety Assessment	3
Symbols	4
Modes for Stopping	4
Prop. 65 Statement for CA Residents	4
Warning for Explosive Material	4
HSTP® Components	6
Preface	7
Training	8
On-Site/Off-Site Training	8
Training via Video Chat/Phone	8
LFA Articles	8
LFA Videos	8
Installation	9
Tools and Materials Needed	9
The Appropriate Workstation for the Machine	10
Positioning the HSTP®	12
Manual and Electrical Controls	13
Settings and Adjustment	20
Maintenance	34
General Maintenance Prescriptions	34
Lubrication	34
Dismantling for Repair and Replacement	38
Tooling	39
Troubleshooting	42
Common Machine/Part Issues	42
Common Tablet Issues	44
Cleaning	45
Storing the HSTP®	48
Appendix	49
Glossary	49
Description of HSTP® Parts	50
Technical Specifications	51
Maintenance Checklist	52
Diagrams	53
Resources	62

HSTP® Components

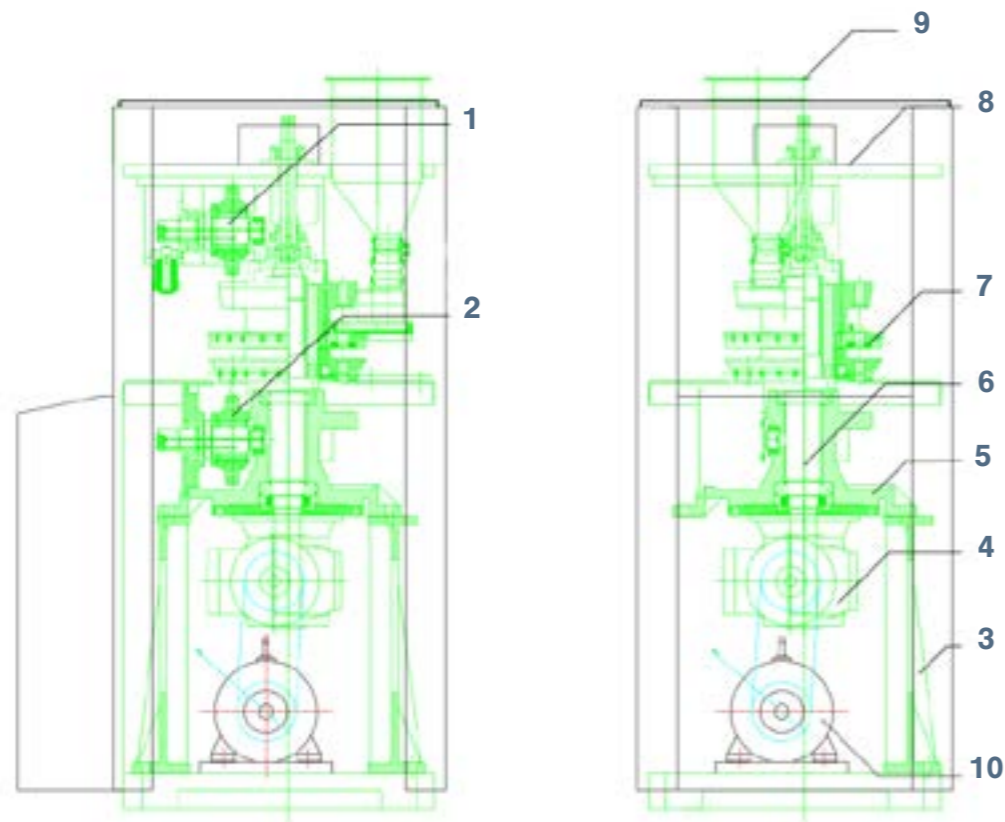

- 1. Upper Pressure Cam Mechanism**
- 2. Lower Pressure Cam Mechanism**
- 3. Frame**
- 4. Gearbox**

- 5. Seat**
- 6. Spindle**
- 7. Turret**
- 8. Support Block**
- 9. Hopper**
- 10. Motor**

Preface



The HSTP® High Speed Tablet Press achieves very high levels of productivity and speed by offering exceptional refinements in terms of safety, efficiency, and quality of output. The HSTP® can produce up to 252,000 tablets an hour with interchangeable dies and create round and shaped tablets up to 25 mm in diameter and 6 mm thick. With an LCD touch screen display panel, this advanced high speed tablet press is very easy to use and possesses features such as an automatic lubrication system, automatic or manual operation, and settings that allow the user to fine-tune adjustments.

The purpose of this document is to support your understanding of the HSTP®'s components, features, functions, and design. With this manual, you will be able to successfully operate and maintain your HSTP® machine.

The user manual's content includes:

- Important safety information
- HSTP® installation instructions
- Description of the HSTP®'s operation
- HSTP® maintenance information
- Appendix with supplemental information

Training

HSTP® training is essential for the machine's successful operation and your personal safety. There are several methods to prepare you for working with the HSTP®.

On-Site/Off-Site Training

LFA technicians can travel and train you at your own facility with your own machines. LFA also offers free training at our UK, USA, and Taiwan facilities for all our customers and their teams. For more information, go to <https://www.lfatabletpresses.com/services>

Training via Video Chat/Phone

Using an online video chat system, an LFA technician can interact face-to-face with you and assist with your understanding of the machine. Or, if you prefer, LFA can provide training via phone for all customers who call the office. To set up a training, call or email your local LFA office:

UK

Phone

+44 01869 250234

Email

support.uk@lfamachines.com

Taiwan

Phone

+886 422031790

Email

support.asia@lfamachines.com

LFA Articles

LFA writes informative articles about desktop tablet presses, which includes instructions, procedures, and guides. To access the articles, go to <https://www.lfatabletpresses.com/articles>

LFA Videos

LFA has created several videos involving the HSTP® and other desktop tablet presses. To access the videos, go to <https://www.lfatabletpresses.com/videos> or <https://www.youtube.com/user/TabletPilPress>

Installation

Tools and Materials Needed

Before you install and operate the HSTP®, it is best to have the following tools and materials on hand for general operation and maintenance:

- Forklift
- Lifting straps
- Anti-vibration feet (4)
- Hammer
- Rubber mallet
- Metric wrench set
- Pliers/grippers
- Flathead screwdriver
- Set of metric Allen keys with ball ends
- Long wire pipe cleaner
- Lubricant (#30 machine oil, #00 boron nitrate, and NSF approved lubricant for food grade products)
- Grease gun
- Toothbrush
- Bagless vacuum
- Cleaner (e.g. Member's Mark Commercial Lemon Disinfectant)
- Sanitizer (e.g. Member's Mark Commercial Sanitizer)
- Cleaning brush set
- Plastic sheet or something similar to cover machine
- Safety goggles
- Disposable latex/rubber gloves
- Hairnet and/or beard net (food grade products only)
- Sterile shoe covers (food grade products only)

The Appropriate Workstation for the Machine

Find a stable workspace surface that supports the HSTP®'s weight.

Machine Weight and Floor Loading (Static)		
HSTP 26™	1750 kg (3858 lbs)	23.08 kN/m ²
HSTP 32™	1750 kg (3858 lbs)	23.08 kN/m ²
HSTP 40™	1750 kg (3858 lbs)	23.08 kN/m ²

The machine's motor requires a three-phase power supply of 220 V (US) or 380 V (UK). Ensure to position the machine near an appropriate electrical plug.

Environmental Conditions

It is important that the environment in which you operate and store the HSTP® has the appropriate temperature and relative humidity levels. These two environmental factors can potentially cause the machine to rust and/or cause the tablets to have a lower quality. The table below shows the acceptable temperature and relative humidity levels:

Machine	Temperature		Humidity
	°C	°F	
HSTP® Range	18-24	64-75	45-65% RH

The shipping crate will contain the following:

1. The assembled HSTP®



2. The Tooling (already installed)



Positioning the HSTP®

WARNING: To prevent personal injury, wear steel toe boots and heavy duty grip gloves while transporting the HSTP®.



LFA does NOT recommend carrying the machine manually but rather with a forklift. At least two people should be involved (one operating the forklift and one stabilizing the machine) in removing the machine from the shipping container and placing it in the workspace.

Moving the HSTP® with a Forklift

Tools Needed

- Forklift that is rated to lift at least 2000 kg
- Lifting straps that are rated for at least 2000 kg
- Anti-vibration feet (4)
- Heavy duty grip gloves
- Steel toe boots

Instructions

1. Feed the lifting straps around the machine.
2. Position the forks of a forklift truck over the top of the machine and securely attach the lifting straps.
3. Carefully lift the machine off the pallet and attach the anti-vibration feet.
4. Lower the machine so that it is no more than 2-3 cm off the floor.
5. Position the machine in the desired location and carefully lower the machine.

Manual and Electrical Controls

Basic Components



A description of the principal components follows:

- The **Hopper** holds the dry materials that will be compressed.
- The **Force Feeder** distributes the dry materials into the Die bores and its Take-Off Blade pushes tablets into the Tablet Chute.
- The **Dies** define the size and shape of the powder.
- The **Upper Punches** and **Lower Punches** compress the materials within the Dies.
- The **Turret** houses the Tooling.
- The **Upper Pre-Pressure Roller Cam** and **Lower Pre-Pressure Roller Cam** provide the initial compression force onto the powder to remove any air within the Die bore or powder particles.
- The **Upper Roller Cam** and **Lower Roller Cam** compress the Upper Punches and Lower Punches to create the tablet.

Control Console



1. Adjusts the main pressure.
2. Adjust the pre-pressure.

3. Adjusts the tablet weight.
4. Raises/lowers the Upper Punch by 5 mm.

Control Console (Machine State)

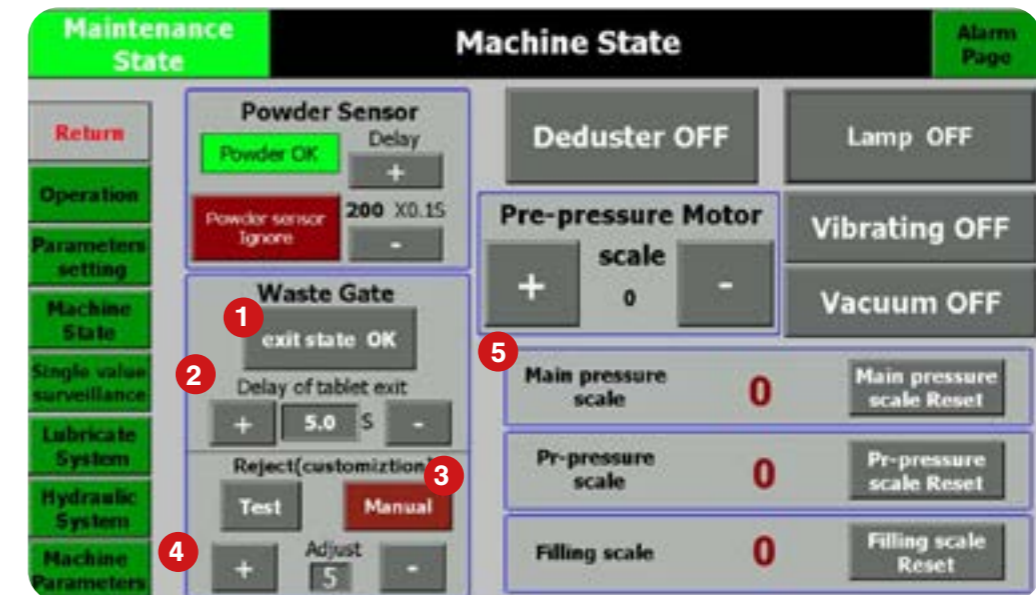

1. Reroutes tablet ejection from the main chute to the secondary chute (Waste Gate) for testing.
2. Sets the time for rerouting tablet ejection.
3. Sets tablet ejection rerouting to automatic or manual.
4. Adjusts the tablet amount to be rerouted into the secondary chute.
5. Shows the amount of the main pressure, pre-pressure, and filling during operation.

Control Console (Lubricate System)

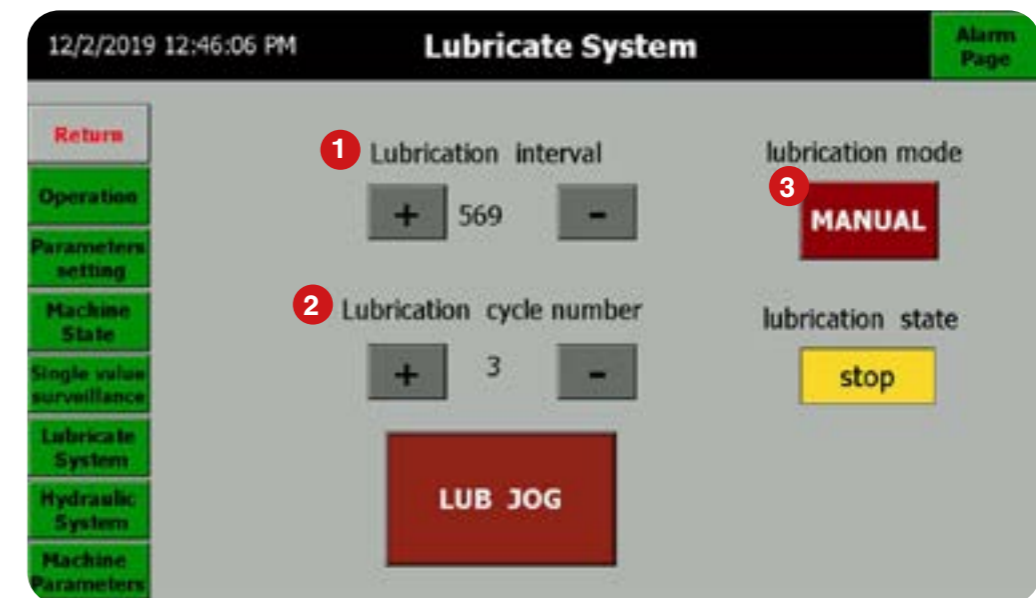

1. Adjust the amount of machine rotation cycles for lubrication (e.g. every 569 cycles the pump will lubricate).
2. Adjust the amount of machine rotation cycles the lubrication pump will run.
3. Switch from automatic to manual lubrication mode.

Control Console (Operation)

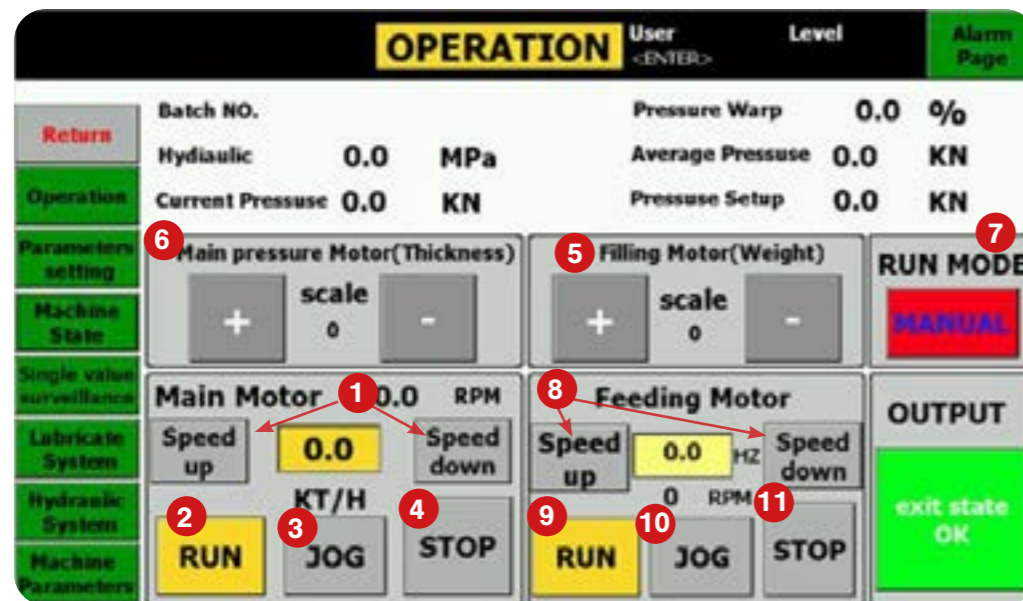

1. Adjusts Turret speed.
2. Starts the machine.
3. Jogs the machine.
4. Turns off the machine.
5. Adjusts the fill depth.
6. Adjusts the punch pressure.
7. Switches between manual and auto operation.

8. Adjusts Force Feeder speed.
9. Starts the Force Feeder.
10. Jogs the Force Feeder.
11. Stops the Force Feeder.

HSTP® Process

The basic mechanism of the HSTP® involves filling the Tooling (Dies, Upper Punches, and Lower Punches) with powder, compressing the powder, and ejecting the tablets.

Filling the Tooling with Powder

The dry materials are poured into the Hopper and funneled into Force Feeder via the connecting pipe. As the machine operates, the Turret moves, which causes the Upper Punches to withdraw from the Dies. During this process, powder is fed by the Force Feeder into the moving Turret and the Die bores.

Compressing the Powder

After the Die bore is filled with powder, the Upper Punch is driven into the Die. The Upper and Lower Punches then compress the powder under high pressure.

Ejecting the Tablet

After both punches compress the powder into a tablet, the Upper Tooling is withdrawn and the tablet is then pushed out of the Die bore by the Lower Punch. Once the tablet has been ejected out of the Die bore, it is slid out of the way by the Force Feeder's Take-Off Blade to prepare for the next tablet compression.



How to Create Tablets with the HSTP®

Tools and Materials Needed

- Raw material formulation
- HSTP®
- Safety goggles
- Disposable latex/rubber gloves (for food grade products and to protect hands from grease)
- Hairnet and/or beard net (food grade products only)
- Sterile shoe covers (food grade products only)



WARNING: For personal protection while operating the HSTP™, contain long hair and do not wear loose jewelry

Instructions

Note: Wear latex/rubber gloves (and appropriate food grade attire if applicable) during this process.

1. Turn the Hand Wheel manually clockwise to ensure proper machine operation.
2. Pour the dry materials into the Hopper and manually press a tablet to avoid the chance of jamming the machine.
3. Plug in the HSTP® to an outlet.
4. Start up the machine's digital touch screen by disengaging the Emergency Stop button.
5. Press LOGIN and enter the following credentials on the touch screen panel:

Log on ✕

User:

Password:

6. Press the Operation button on the touch screen panel.

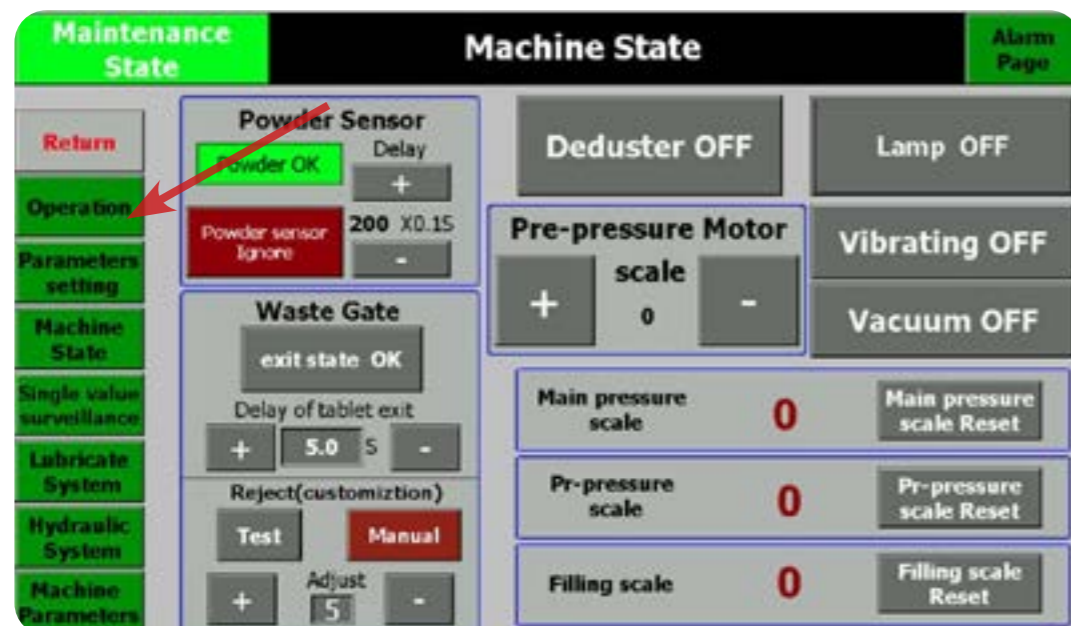

7. Change the run mode to automatic by pressing the MANUAL button.
8. Press the RUN button in the Main Motor section to start the machine operation.

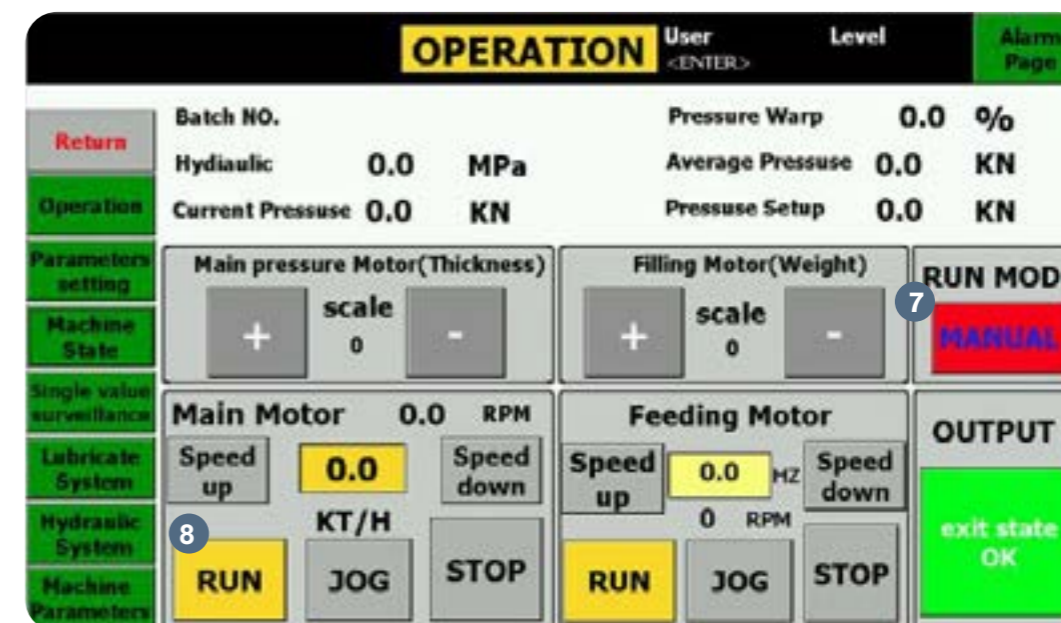

Settings and Adjustment

The HSTP®'s settings can be adjusted. Tuning the Tooling can help with changing the tablets' characteristics and how they are ejected from the machine.

Fill Depth (option #1)

At times, a tablet will be too light or too heavy, and its weight must change. Adjusting the fill depth determines the tablet's thickness and weight. This can be controlled by changing how high or low the Lower Punch sits.

Tools and Materials Needed

- Disposable latex/rubber gloves (for food grade products and to protect hands from grease)
- Hairnet and/or beard net (food grade products only)
- Sterile shoe covers (food grade products only)

Instructions

Note: Wear latex/rubber gloves (and appropriate food grade attire if applicable) during this process.

1. Produce a test tablet to determine how the Tooling should be adjusted.
2. Turn the middle right-hand knob to adjust the fill depth.
 - 2.1 Note: Turn the knob clockwise to increase the fill depth and counterclockwise to decrease the fill depth.



Fill Depth (option #2)

Tools and Materials Needed

- Disposable latex/rubber gloves (for food grade products and to protect hands from grease)
- Hairnet and/or beard net (food grade products only)
- Sterile shoe covers (food grade products only)

Instructions

Note: Wear latex/rubber gloves (and appropriate food grade attire if applicable) during this process.

1. Produce a test tablet to determine how the Tooling should be adjusted.
2. Press the Filling Motor (Weight) buttons on the touchscreen to adjust the fill depth.

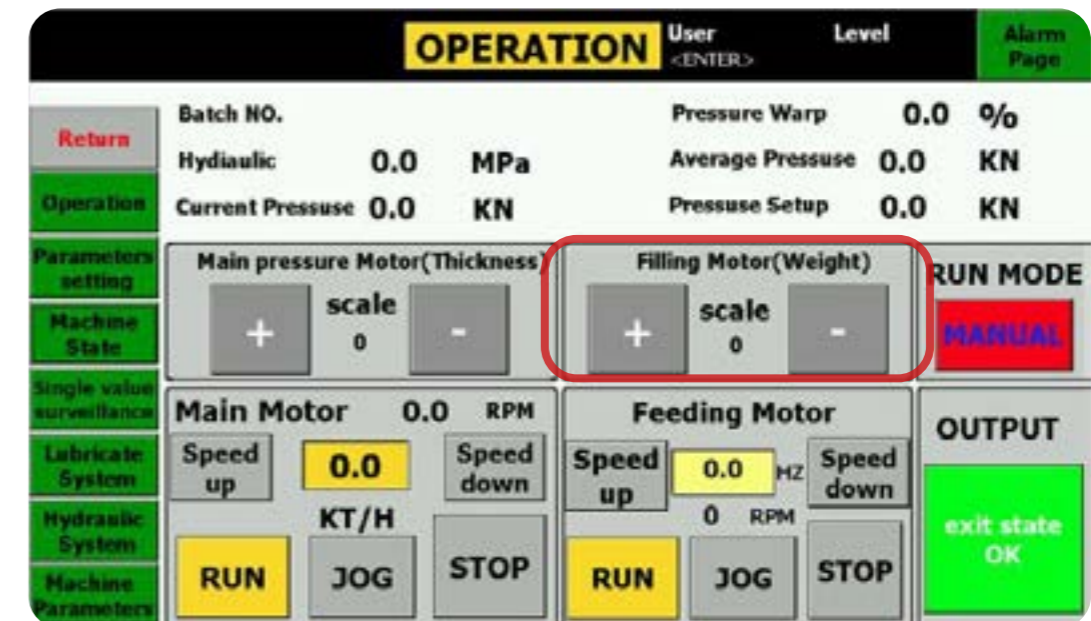

Pre-Pressure Thickness

The pre-pressure thickness could be adjusted in the event that ejection forces are exceedingly high and it needs to be reduced, or it needs to be increased to help with air elimination in powder.

Tools and Materials Needed

- Disposable latex/rubber gloves (for food grade products and to protect hands from grease)
- Hairnet and/or beard net (food grade products only)
- Sterile shoe covers (food grade products only)

Instructions

Note: Wear latex/rubber gloves (and appropriate food grade attire if applicable) during this process.

1. Produce a test tablet to determine how the Tooling should be adjusted.
2. Turn the middle left-hand knob to adjust the pre-pressure.
 - 2.1 Note: Turn the knob clockwise to lower the pre-pressure and counterclockwise to increase the pre-pressure.



Punch Pressure (option #1)

Sometimes tablets come out too soft and will crumble easily, which happens often after increasing the fill depth. Or, the machine can jam and will not be able to turn over. To correct this, the punch pressure needs to be adjusted in order to increase the tablet's firmness/de-jam the machine.

Tools and Materials Needed

- Disposable latex/rubber gloves (for food grade products and to protect hands from grease)
- Hairnet and/or beard net (food grade products only)
- Sterile shoe covers (food grade products only)

Instructions

Note: Wear latex/rubber gloves (and appropriate food grade attire if applicable) during this process.

1. Produce a test tablet to determine how the Tooling should be adjusted.
2. Turn the left-hand knob to adjust the pressure.
 - 2.1 Note: Turn the knob clockwise to lower the pressure and counterclockwise to increase the pressure.



CAUTION: Applying too much pressure can damage the machine and/or Tooling. The appropriate amount of pressure depends on the dimension and shape of the Tooling. Please refer to the table on the page 25 for more details.

Punch Pressure (option #2)

Sometimes tablets come out too soft and will crumble easily, which happens often after increasing the fill depth. Or, the machine can jam and will not be able to turn over. To correct this, the punch pressure needs to be adjusted in order to increase the tablet's firmness/de-jam the machine.

Tools and Materials Needed

- Disposable latex/rubber gloves (for food grade products and to protect hands from grease)
- Hairnet and/or beard net (food grade products only)
- Sterile shoe covers (food grade products only)

Instructions

Note: Wear latex/rubber gloves (and appropriate food grade attire if applicable) during this process.

1. Produce a test tablet to determine how the Tooling should be adjusted.
2. Press the Main Pressure Motor (Thickness) buttons on the touchscreen to adjust the punch pressure.

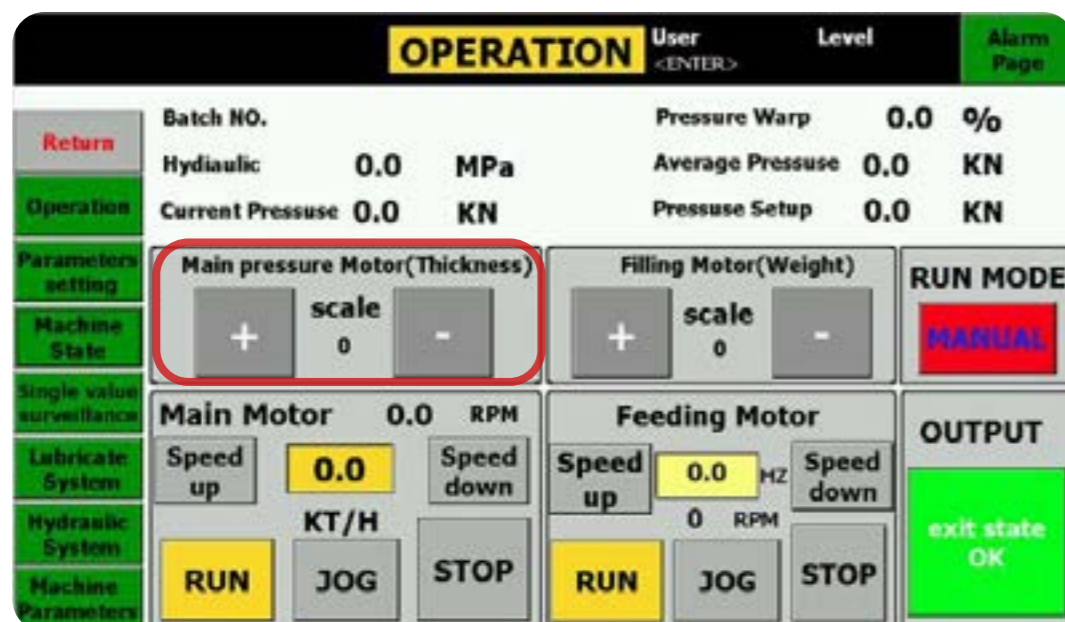

CAUTION: Applying too much pressure can damage the machine and/or Tooling. The appropriate amount of pressure depends on the dimension and shape of the Tooling. Please refer to the table on the next page for more details.

Tablet Pressure Guide

Die Diameter	Area mm ²	Flat Face Tablet 1 mm ² 0.8 kN	Shallow Concave Tablet 1 mm ² 0.8 kN	Deep Concave Tablet 1 mm ² 0.3 kN
3	7.07	5.65	3.53	2.12
4	12.57	10.05	6.28	3.77
5	19.63	15.71	9.82	5.89
6	28.27	22.62	14.14	8.48
7	38.48	30.79	19.82	11.55
8	50.27	40.21	25.13	15.08
9	63.62	50.89	31.81	19.09
10	78.54	62.83	39.27	23.56
11	95.03	76.03	47.52	28.51
12	113.10	90.48	56.55	33.93
13	132.73	106.20	66.37	39.82
14	153.94	123.2	76.97	46.18
15	176.71	141.4	88.36	53.01
16	301.06	106.8	100.5	60.32
17	226.98	181.6	113.5	68.09
18	254.47	203.6	127.2	76.34
19	283.53	226.8	141.8	85.06
20	314.16	251.3	157.1	94.25
21	346.36	277.1	173.2	103.9

Turret Speed

Once the characteristics of tablet production are satisfactory, it might be appropriate to increase the Turret speed in order to raise maximum output.

Tools and Materials Needed

- Disposable latex/rubber gloves (for food grade products and to protect hands from grease)
- Hairnet and/or beard net (food grade products only)
- Sterile shoe covers (food grade products only)
-

Instructions

Note: Wear latex/rubber gloves (and appropriate food grade attire if applicable) during this process.

1. Produce a test tablet to determine how the Tooling should be adjusted.
2. Press the Speed Up and Speed Down buttons in the Main Motor section on the touchscreen to adjust the Turret speed.

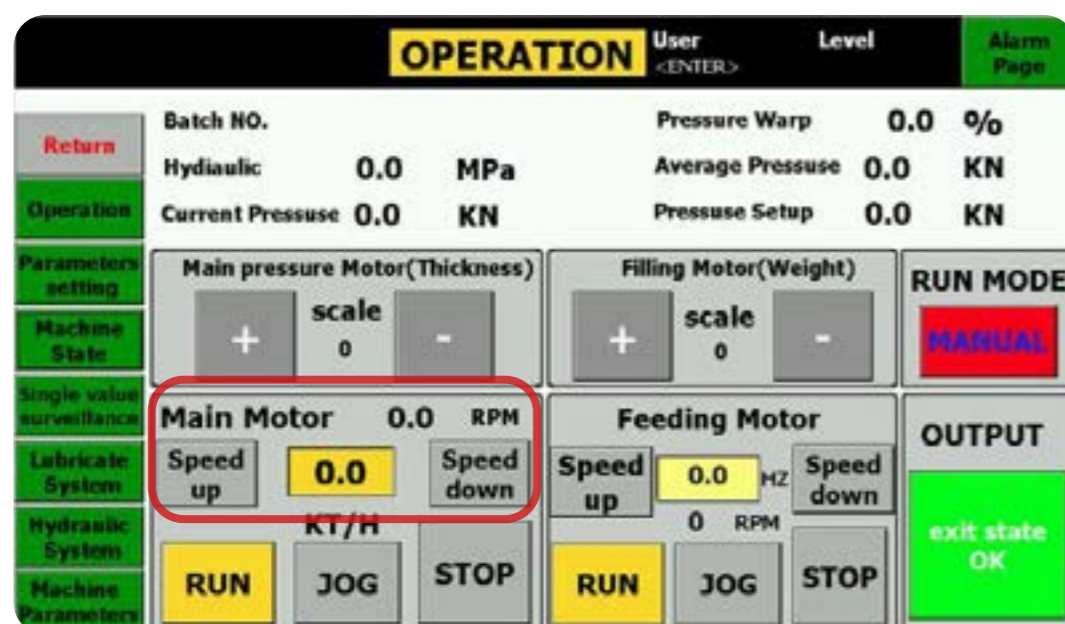

Force Feeder Speed

The Force Feeder's speed can be increased to address any flow issues with the powder.

Tools and Materials Needed

- Disposable latex/rubber gloves (for food grade products and to protect hands from grease)
- Hairnet and/or beard net (food grade products only)
- Sterile shoe covers (food grade products only)
-

Instructions

Note: Wear latex/rubber gloves (and appropriate food grade attire if applicable) during this process.

1. Operate the machine in automatic mode to determine how the Force Feeder should be adjusted.
2. Press the Speed Up and Speed Down buttons in the Feeding Motor section on the touchscreen to adjust the Force Feeder speed.

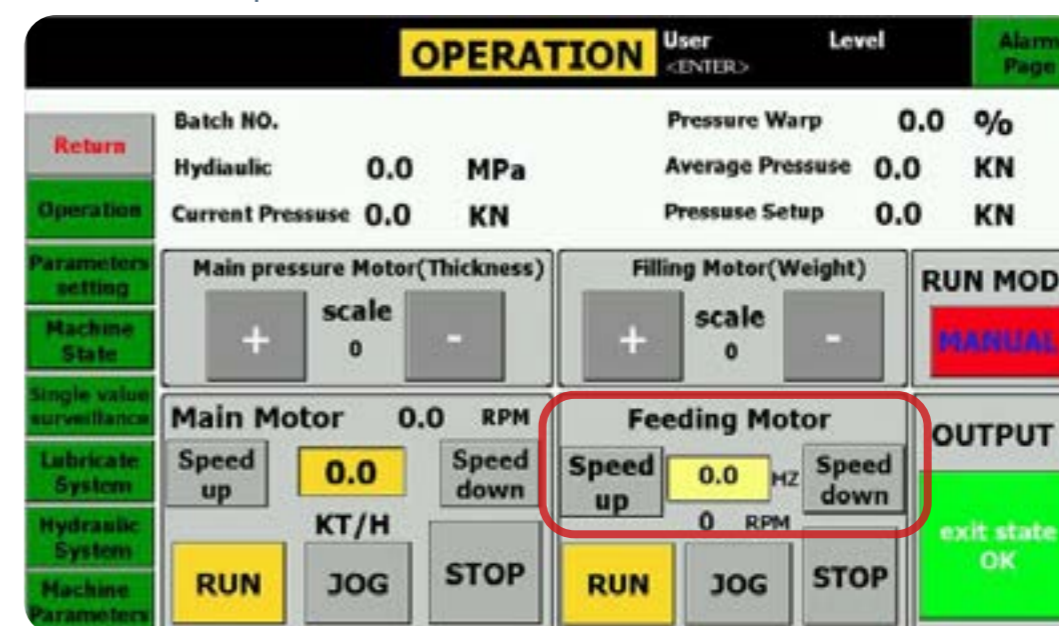

Force Feeder Calibration

The size of granules in your powder can affect how smoothly dry materials are moved through the Force Feeder, which can affect how much powder is wasted. Sometimes this requires the Force Feeder's height to be adjusted.

To watch a video of a Force Feeder calibration on a similar machine, go to <https://www.lfatabletpresses.com/rtp10i-force-feeder-calibration>

Tools and Materials Needed

- Set of metric Allen keys
- Feeler gauge
- Wrench set
- Level
- Disposable latex/rubber gloves (for food grade products and to protect hands from grease)
- Hairnet and/or beard net (food grade products only)
- Sterile shoe covers (food grade products only)



WARNING: To prevent any potential personal injury, unplug the HSTP® from the electrical outlet.

Instructions

Note: Wear latex/rubber gloves (and appropriate food grade attire if applicable) during this process.

1. Raise each of the Perspex Casing's doors and lock them into an upward position.
2. Remove the Hopper and the Hopper to Force Feeder Connecting Pipe.
3. Loosen the Force Feeder's bolts underneath and remove it.
4. Loosen the Force Feeder Height Adjustment Base.
5. Adjust the three Force Feeder Height Adjusters with a wrench/by hand.
 - 5.1 Note: To raise the Force Feeder Adjustment Base, turn counterclockwise. To lower the Force Feeder, turn clockwise.
6. Place a level on the Force Feeder Adjustment Base and make any necessary adjustments to ensure that it is flat.
7. Place the Force Feeder back on the Force Feeder Adjustment Base and run a feeler gauge underneath the Force Feeder to determine the adjustment.
 - 7.1 Note: Start at 0.15 mm and raise appropriately if there is no powder waste/damage to the Force Feeder Adjustment Base. If there is waste, lower it.
8. Tighten the Force Feeder's bolts.
9. Resecure the Hopper to Force Feeder Connecting Pipe.
10. Insert the Hopper into the Force Feeder.
11. Lower the Perspex Casing's doors.



Update HMI Program

Periodically the HMI's control console software is updated to optimize machine operation and to fix any bugs/errors.

Tools and Materials Needed

- USB drive with new HMI program
- Disposable latex/rubber gloves (for food grade products and to protect hands from grease)
- Hairnet and/or beard net (food grade products only)
- Sterile shoe covers (food grade products only)



WARNING: To prevent any potential personal injury, unplug the HSTP® from the electrical outlet.

Instructions

Note: Wear latex/rubber gloves (and appropriate food grade attire if applicable) during this process.

1. Open the panel below the HMI to access its ports.
2. Insert the USB drive with the new HMI program loaded in it into the USB port of the HMI.
3. Turn the Isolator Switch to power on the machine.
4. Press Control Panel.

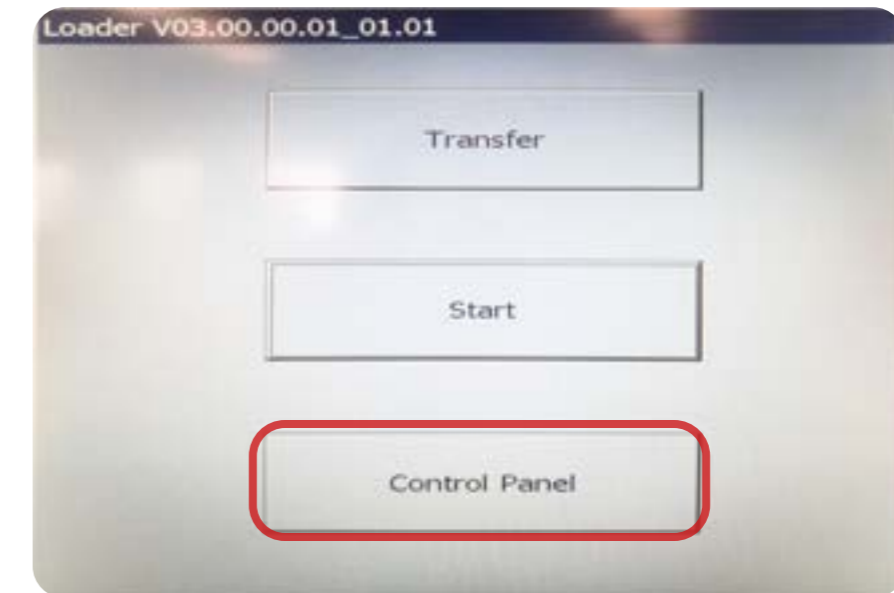

5. Double click Service & Commissioning.



6. Press Restore.

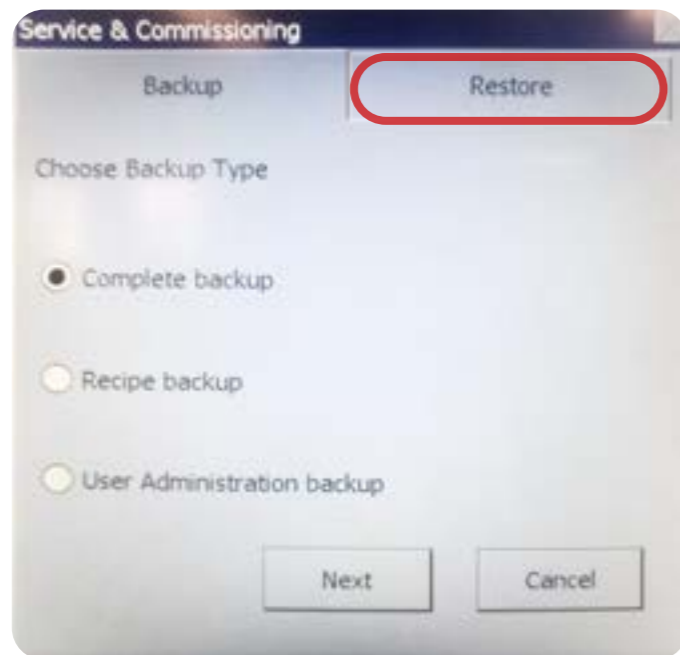

7. Press Next.

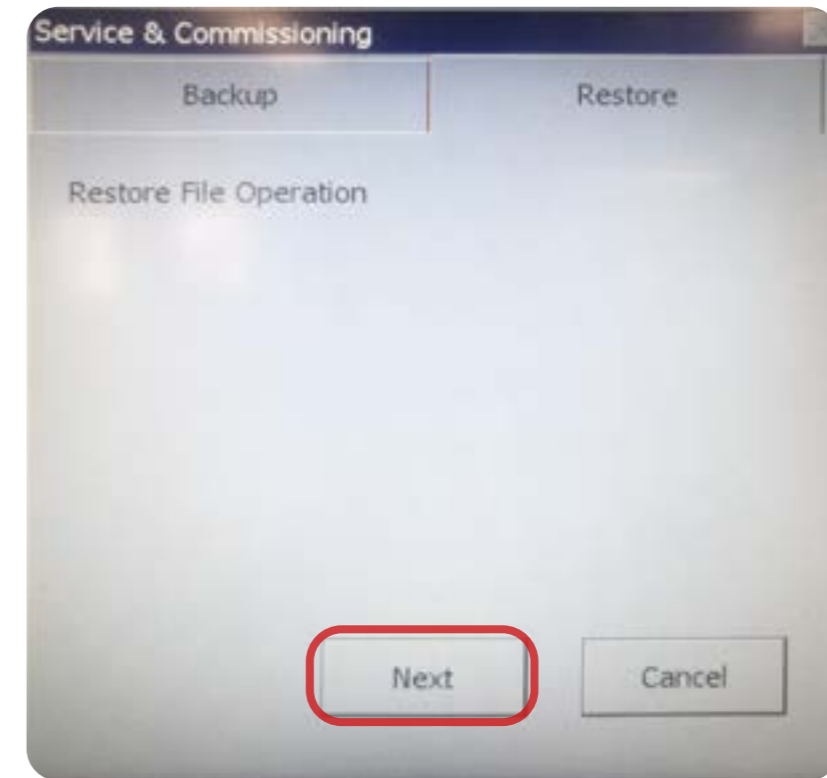

8. Select the USB device and press Next.

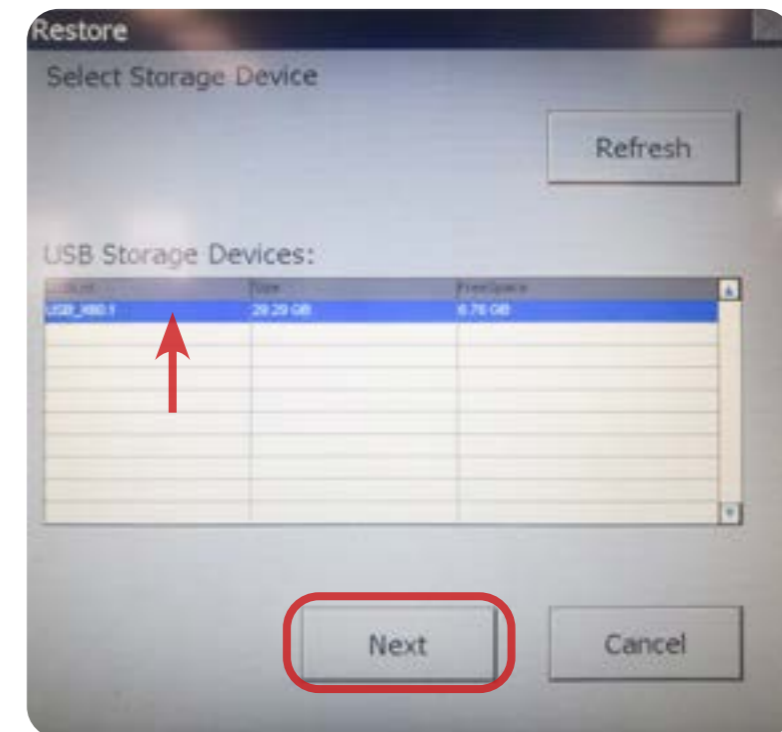

9. Select the HMI program stored on the USB and press Next.

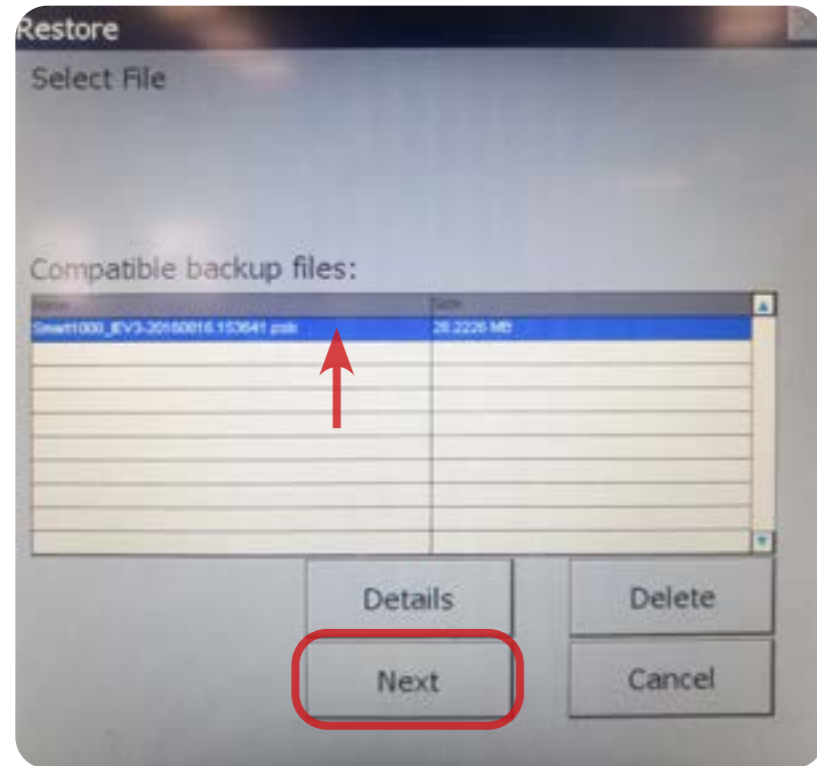

10. Press Start.

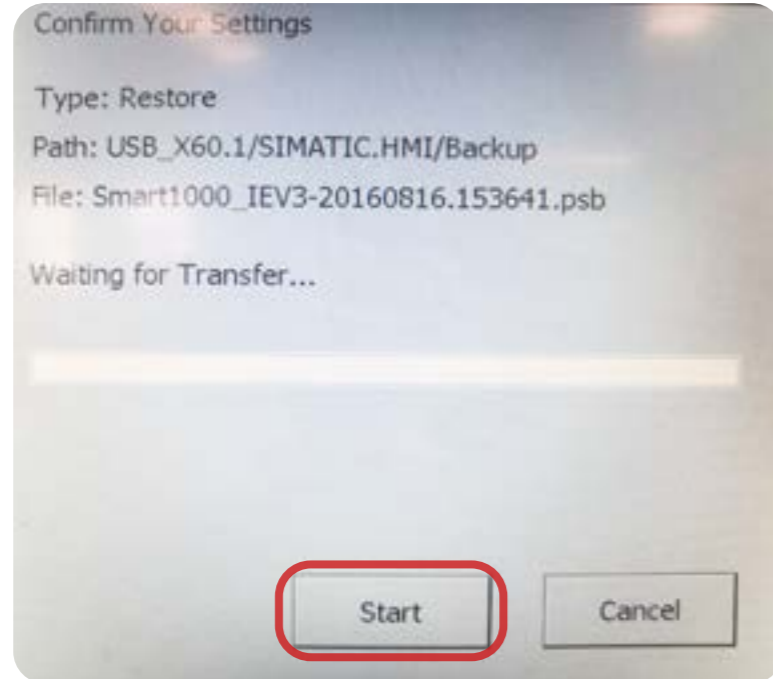

11. Wait for the restore operation to complete.

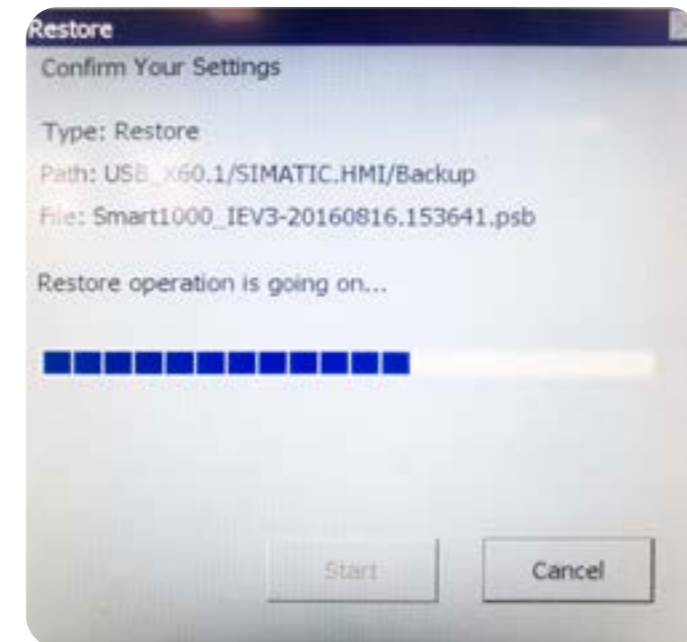

12. Wait for the machine to reboot before beginning operation with updated HMI software.



Maintenance

To ensure that the HSTP® will have a long operational life, maintenance is essential. This section includes methods for replacing parts, troubleshooting solutions, and how often to grease and clean your machines to keep its performance optimal.

General Maintenance Prescriptions

- Use the maintenance checklist (found in the Appendix) before, during, and after machine operation.
- Make sure all grease points are maintained and regularly lubricated.
- Use an appropriate amount of lubricant. Excess grease can drip into the tablets as they are formed.
- Before reassembling the machine after cleaning, make sure that the parts are dried and oiled.
- Constantly check for any loose nuts and/or screws before, during, and after machine operation.
- If the machine is not used for more than a week, place the Tooling in an air-tight container and cover in lubricant.

Lubrication

NOTE: These machines are constructed using packing grease. If food grade lubricant is required for your production facility, remove the grease and oil and replace with appropriate food grade lubrication.

Regularly greasing your machine is vital to prolonging its operational life. Parts that are not greased properly can make the machine seize up and cause major problems later. LFA recommends maintaining a lubrication schedule for your HSTP®, which can be found in this section.

The HSTP® comes with an automatic thin-oil lubrication system that includes a power-driven lubrication pump and multi-route oil distribution. This system will lubricate the upper and lower cams, the Lower Pre-Pressure Roller Cam, and Upper and Lower Punches every 200 Turret rotations.

The HSTP® also possesses a manual dry lubrication system that incorporates the use of a manual pump to distribute lubricant to the lever driving mechanism, fill mechanism, upper and lower eccentric shafts, and the pre-pressure oil vat.

Tools and Materials Needed

- #30 machine oil and #00 boron nitrate
- Set of metric Allen keys with ball ends
- Disposable latex/rubber gloves (for food grade products and to protect hands from grease)
- Hairnet and/or beard net (food grade products only)
- Sterile shoe covers (food grade products only)



WARNING: To prevent any potential personal injury, unplug the HSTP® from the electrical outlet.

Instructions (continued on next page)

Note: Wear latex/rubber gloves (and appropriate food grade attire if applicable) during this process.

1. Press the Lubricate System button on the touchscreen.

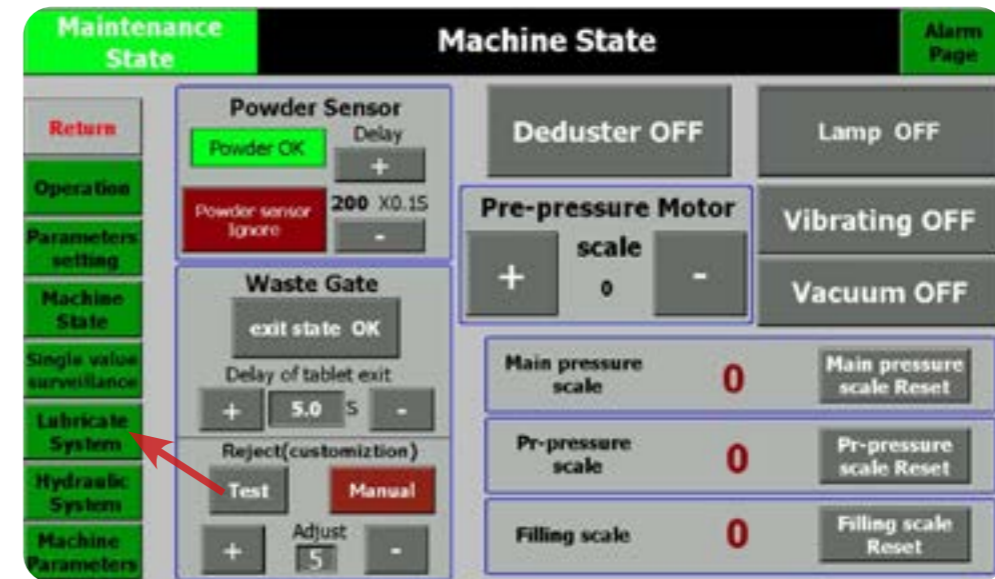

2. Change the Lubrication Mode to MANUAL by pressing its button.
3. Adjust the Lubrication Interval and Lubrication Cycle Number buttons to change the lubrication speed and frequency.

3.1 Note: The Lubrication Interval indicates the amount of cycles the machine will run before lubrication begins. The Lubrication Cycle Number shows how many Turret cycles the lubrication will run.

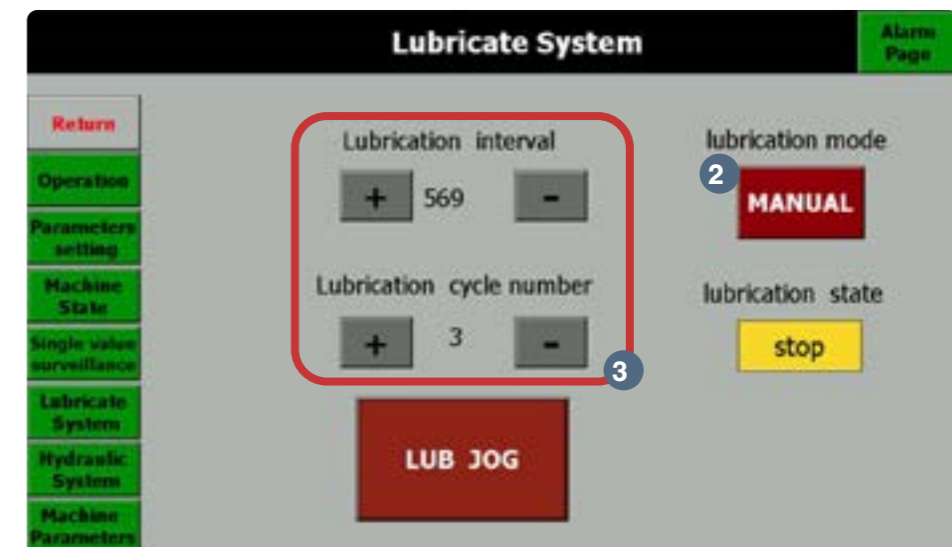

4. Pour #30 machine oil into the automatic lubrication system container.
5. Manually pump the dry lubrication system to distribute the lubricant.
6. Pour #00 boron nitrate into the dry lubrication system container.



Lubrication Schedule

LFA recommends the following HSTP® parts to be lubricated according to the following frequency:

Part	Location	Image	Frequency	Type of Lubricant
Tooling Heads	The heads of the Upper Punch and Lower Punch		Visually inspect and apply when dry	NLGI Grade 1
Tooling (after cleaning)	Storage container		Apply after cleaning	Mineral oil
Worm Reducer	Visible after opening left door panel		Apply after every 400-500 hours	#460 worm oil in winter and #680 worm oil in summer
Hydraulic Stem	Inside machine		Apply regularly	#22 turbine oil
Spindle Bearing	Behind the back door panel		Apply every 200 hours	Lithium grease

Dismantling for Repair and Replacement

Eventually due to wear and tear, some parts of the HSTP® will need to be removed for repair and replacement. To prevent any delays in your tablet production, it is best practice to keep extra parts just in case.

To buy a HSTP® part replacement, simply go to <https://www.lfatabletpresses.com/products/pill-press-machine-spare-parts/hstp-parts>

Warranty

To access LFA's warranty policy, go to <https://www.lfatabletpresses.com/warranty>
If your part is eligible for warranty, have your part's serial number on hand and please contact LFA:

UK

Phone

+44 01869 250234

Email

support.uk@lfamachines.com

USA

Phone

+1 (682) 312-0309

Email

support.usa@lfamachines.com

Taiwan

Phone

+886 422031790

Email

support.asia@lfamachines.com



WARNING: To prevent any potential personal injury, ALWAYS unplug the HSTP® from the electrical outlet when replacing parts.

Tooling

If you want to change the shape and diameter of the tablet, or if the Upper Punches, Lower Punches, and/or Dies you currently have are damaged, it is necessary to change the Tooling. To buy new Tooling from LFA, simply go to <https://www.lfatabletpresses.com/products/tablet-press-tooling>

Tools and Materials Needed

- Set of metric Allen keys with ball ends
- Set of metric wrenches
- Crosshead screwdriver
- Tooling/die set (Upper Punches, Dies, and Lower Punches)
- Die Removal Bar and rubber mallet
- Disposable latex/rubber gloves (for food grade products and to protect hands from grease)
- Hairnet and/or beard net (food grade products only)
- Sterile shoe covers (food grade products only)



WARNING: To prevent any potential personal injury, ALWAYS unplug the HSTP® from the electrical outlet when replacing parts.

CAUTION: To prevent damage to the Tooling, adjust the punch pressure so that tablet thickness is at its maximum.

Instructions

Note: Wear latex/rubber gloves (and appropriate food grade attire if applicable) during this process.

Remove the Tooling

1. Raise each of the Perspex Casing's doors and remove the panel doors.
2. Loosen the Hopper to Force Feeder Connecting Pipe and remove the Hopper.



3. Remove the Force Feeder from the machine.
4. Remove the Upper Tooling Shroud.
5. Rotate the Hand Wheel until an Upper Punch is accessible.
6. Pull up the Upper Punch.
7. Repeat steps 5-6 until all Upper Punches are removed.

8. Remove the Lower Punch Retaining Block with an Allen key.



9. Rotate the Hand Wheel until a Lower Punch is aligned with the location where the Lower Punch Retaining Block was.

10. Gently pull on the Lower Punch's head through the hole.

11. Repeat steps 9-10 until all Lower Punches are removed.

12. Loosen the set screws surrounding one of the Dies.

13. Place the Die Removal Bar underneath the Die.

14. Hit the Die Removal Bar with a rubber mallet until the Die emerges from the Turret.

15. Repeat steps 13-14 until all Dies are removed.

Note: To help ensure that the Die is inserted correctly, LFA recommends using an Insertion Ring. You can order the Die Seat Cleaner and Insertion Ring on our website at <https://www.lfatabletpresses.com/die-seat-cleaner-insertion-ring>



Replace the Tooling

16. Position the new Die on the Turret.

16.1 Note: Place a bit of grease around the new Die's sides to make insertion easier.

17. Insert the Die Installation Bar through the Upper Punch's hole and over the new Die.

18. Tap the Die Installation Bar with a rubber mallet until the new Die is inserted into the Turret.

18.1 Note: Make sure that the new Die is flush with the Turret.

19. Reinsert the Die's set screws in the Turret and tighten.

20. Rotate the Hand Wheel until the next new Die can be inserted.

21. Repeat steps 18-22 until all the new Dies are secured in the Turret.

22. Insert a new Lower Punch up through the Lower Punch Retaining Block's hole and into the new Die's bore.

22.1 Note: Lubricate the barrel of the Lower Punch.

23. Rotate the Hand Wheel until the next new Lower Punch can be inserted.

24. Repeat step 22-23 until all the new Lower Punches are inserted into the Turret.

25. Resecure the Lower Punch Retaining Block with an Allen key.

26. Insert a new Upper Punch through the top of the Turret.

26.1 Note: Lubricate the barrel of the Upper Punch.

27. Place the new Upper Punch's head on the Upper Tracking.

27.1 Note: Be sure that the new Upper Punch's head is above the Upper Tracking to prevent damage.

28. Rotate the Hand Wheel until the next new Upper Punch can be inserted.

29. Repeat steps 26-28 until all the new Upper Punches are inserted into the Turret.

30. Resecure the Upper Tooling Shroud.

31. Resecure the Force Feeder on the machine.

32. Reinsert the Hopper to Force Feeder Connecting Pipe along with the Hopper.

33. Lower all the Perspex Casing's doors and reattach the panel doors.

Troubleshooting

Sometimes unavoidable issues will occur while operating the HSTP®. Fortunately, there are several methods to remedy these issues.

Common Machine/Part Issues

Symptom	Possible Cause	Possible Solution
Machine freezes or locks up	Grease point areas are dry.	Regularly oil and grease all the Grease Nipples and high friction areas.
	There is excess pressure.	Rotate the Pressure Knobs on the machine counterclockwise.
	There is caking of powder in the machine.	Take apart the Turret and Tooling and clean.
Knocking sounds coming from machine	There is excess pressure.	Rotate the Pressure Knobs on the machine counterclockwise.
	Parts may be loose.	Check the machine's parts and tighten as necessary.
	The Gearbox needs oil.	Check the Gearbox's oil gauge and lubricate as necessary.
Heavy resistance during production	The high friction areas are either unclean, locked, worn out, or not greased properly.	Apply grease to the Grease Nipple points and all high friction areas and/or clean the machine.
Excess machine vibration	The machine has no anti-vibration feet or they are worn.	Place new anti-vibration feet on the bottom of the machine.
	Parts may be loose.	Check the machine's parts and tighten as necessary.
Excess powder waste	The dry materials are moving too fast.	Lower the Hoppers' height to reduce powder flow.
	The Fill Trays are too high or unlevelled.	Adjust the Fill Trays, Take-Off Blades, and Scrapers accordingly.
	There is a gap between the Turret and the Machine Base.	Apply NLGI Grade 4 grease to the gap between the Turret and Machine Base.

Symptom	Possible Cause	Possible Solution
Inability to compact materials to tablet form	The Fill Trays are blocked and not enough materials are flowing out.	Check the Fill Trays for a potential clog.
	There is not enough pressure.	Rotate the Pressure Knobs on the machine clockwise.
	The Tooling is damaged.	Remove and replace the Tooling (all Upper Punches, Lower Punches, and Dies).
	There are flowing issues with the mix.	If the machine is able to make tablets with LFA's Firmapress®, then the problem is your mix. Adjust your formulation. If still an issue, contact LFA for support.
Powder sticks to the Upper Punches	There is damage to the Tooling or the Tooling's design is causing sticking.	Remove and replace the Tooling (all Upper Punches, Lower Punches, and Dies).
	There are issues with the mix.	Adjust your formulation. If still an issue, contact LFA for support.
Powder sticks to the Lower Punches	There are issues with the mix.	Adjust your formulation. If still an issue, contact LFA for support.
Insufficient pressure in hydraulics system (below 7.2 MPa)	The motor pump is spinning in the wrong direction.	Switch the motor's phases in the contactor.
	The pump pressure needs to be adjusted.	Loosen the dome nut, remove the hex nut, and spin the bolt behind with an Allen key.
	The system's air needs bleeding.	Fill the system's reservoir with hydraulic oil and open the bleed tap so that the excess air can get out.

Common Tablet Issues

Symptom	Possible Cause	Possible Solution
Double tablets	Previous tablet did not eject correctly.	Remove the double tablet manually from the Die bore.
	Excess granular materials were placed in the Die, which prevented the ejection of the existing tablet.	Clean the Tooling to remove any excess granular materials and make sure that it is clean and completely dry.
Cracked or broken tablets	There are problems with the formulation of the granules and ingredients.	If the machine is able to make tablets with LFA's Firmapress®, then the problem is your mix. Adjust your formulation. If still an issue, contact LFA for support.
	The Fill Trays are not feeding enough material to be pressed in tablet form.	Adjust the Fill Trays, Take-Off Blades, and Scrapers accordingly.
	There is excess pressure.	Please read our article on Capping at https://www.lfatabletpresses.com/articles/tablet-capping
Inconsistent Tablet Weight	Lower Punches are loose.	Check for loose Lower Punches and insert correctly if necessary.
	There are flowing issues with the mix.	If the machine is able to make tablets with LFA's Firmapress®, then the problem is your mix. Adjust your formulation. If still an issue, contact LFA for support.
Soft tablets	There is too little punch pressure.	Rotate the Pressure Knob on the machine counterclockwise.
	There are flowing issues with the mix.	If the machine is able to make tablets with LFA's Firmapress®, then the problem is your mix. Adjust your formulation. If still an issue, contact LFA for support.
Uneven tablets	The Tooling is worn out.	Check the ingredients of your formula before you replace the Tooling.
Broken tablets during ejection	The Ejection Cam is dirty.	Inspect Ejection Cam and clean if necessary.
	The Ejection Cam is worn.	Replace the Ejection Cam.

Cleaning

During the HSTP®'s operation, excess powder will find its way into parts of the machine, particularly in the Hopper, Tooling, and Force Feeder. It is important to clean the HSTP® thoroughly to prevent rusting and cross contamination.

LFA recommends that the machine be cleaned after each operation.

Tools and Materials Needed

- Cleaning brush
- Bagless vacuum
- Long wire pipe cleaner
- Toothbrush
- Cleaner (e.g. Member's Mark Commercial Lemon Fresh Disinfectant)
- Sanitizer (e.g. Member's Mark Commercial Sanitizer)
- Set of metric Allen keys with ball ends
- Crosshead screwdriver
- Flathead screwdriver
- Die Installation/Removal Bar from Toolkit
- Disposable latex/rubber gloves
- Bowl of warm soapy water (nothing abrasive)
- Clean cloths
- Potable water
- Hairnet and/or beard net (food grade products only)
- Sterile shoe covers (food grade products only)



WARNING: To prevent any potential personal injury, ALWAYS unplug the HSTP® from the electrical outlet when replacing parts.

Instructions

Note: Wear safety goggles and latex/rubber gloves (and appropriate food grade attire if applicable) during this process.

Remove Parts

1. Unscrew the Hopper to Force Feeder Connecting Pipe's bolt by hand and remove the Hopper.
2. Remove excess powder and any tablets from the Tablet Ejection Chute with a cleaning brush.

3. Remove the Upper Punches, Lower Punches, Dies, and Force Feeder.
 - 3.1 Note: Please refer to the replace Tooling instructions on page 33 for further assistance.
4. Disassemble the Force Feeder and wash each part with soapy water and a clean cloth.
5. Dry each part immediately after it is cleaned and rinsed.
6. Sanitize each part with a clean cloth.
7. Pull off all the panel doors.
8. Use a brush to bring powder debris out from hard to reach places.
9. Vacuum the top section of the HSTP®.
 - 9.1 Note: Ensure that you vacuum inside the top panel where the Turret is positioned.
10. Vacuum the entire area inside the bottom part of the panel door encasement.
 - 10.1 Note: Be sure to vacuum both levels and all corners of the HSTP® base.

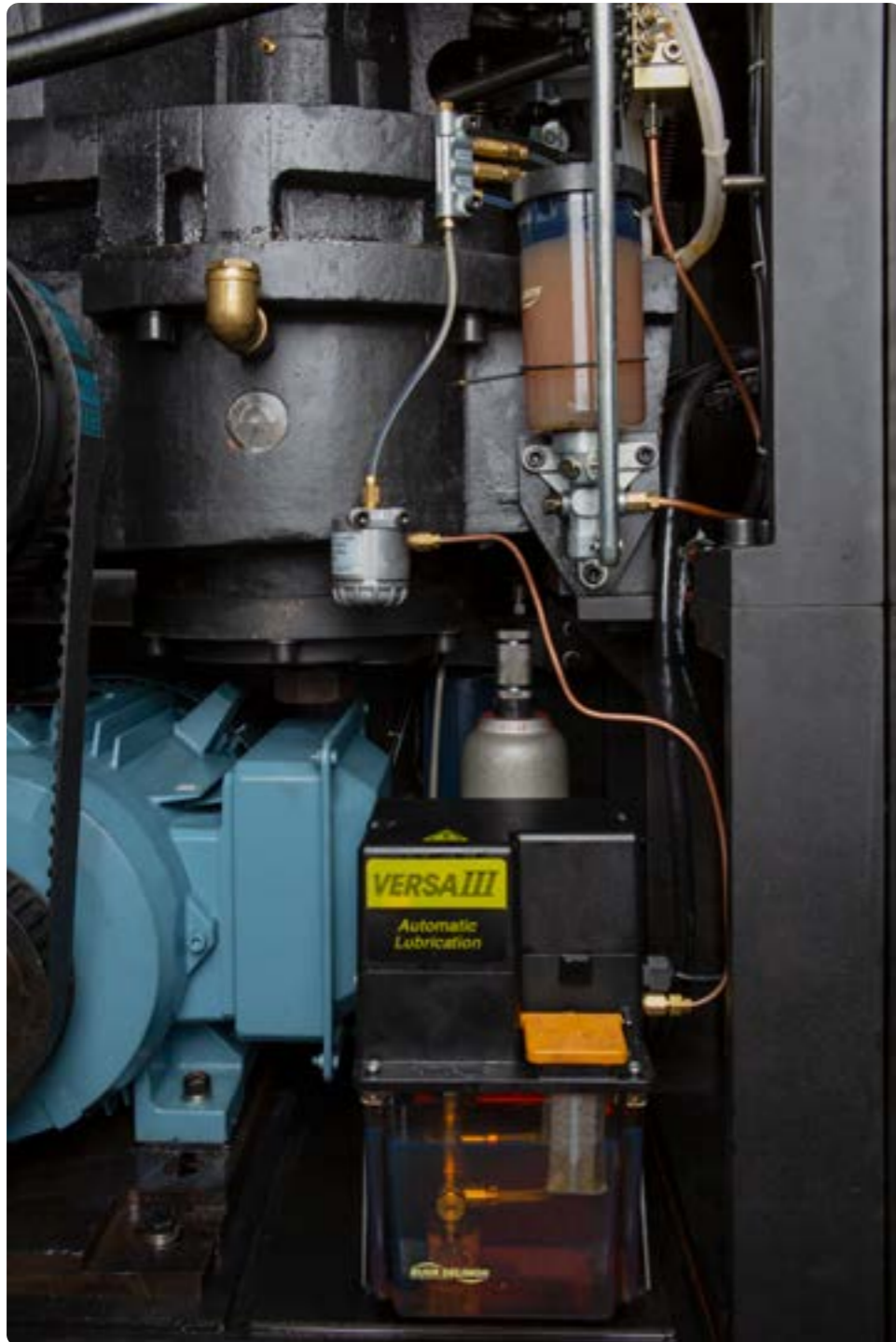

Note: LFA recommends using our Die Seat Cleaner. You can order the Die Seat Cleaner and Insertion Ring on our website at <https://www.lfatabletpresses.com/die-seat-cleaner-insertion-ring>



11. Take an Upper Punch/Lower Punch/Die and bring it to the bowl of soapy water.
 - 11.1 Note: To ensure that all dirt and debris are removed, wash one Tooling piece at a time.
12. Take a clean cloth and carefully wash the part thoroughly.
 - 12.1 Note: Use the toothbrush for difficult-to-remove debris. When cleaning tooling, use non-abrasive cleaning equipment such as a soft pipe cleaner and soft cloth.
13. Dry Tooling piece immediately after it is cleaned and rinsed.
14. Sanitize Tooling piece with a clean cloth.
15. Lubricate the Tooling piece.
16. Repeat steps 11-15 for each remaining piece of Tooling until they are all clean.
17. Spray the HSTP® exterior and interior base with the cleaner, particularly in the Tooling's location.
18. Rinse the cleaner off with potable water and dry the HSTP® base.
19. Sanitize the HSTP® base with a clean cloth.

Storing the HSTP®

After its thorough cleaning, the HSTP® needs to be stored in the proper conditions. It is important to store it in an environment in which the machine is safe from rusting. The HSTP®'s high traction areas and the Tooling need to be lubricated separately before you store them.

Tools and Materials Needed

- Plastic wrapping to cover machine
- Airtight container for Tooling (if in storage for more than a week)
- Lubricant/grease (food grade lubricant if machine has a high chance of contact with the food or drug product)
- Disposable latex/rubber gloves (for food grade products and to protect hands from lubricant)
- Hairnet and/or beard net (food grade products only)
- Sterile shoe covers (food grade products only)

Instructions

Note: Wear latex/rubber gloves (and appropriate food grade attire if applicable) during this process.

Lubricating the Tooling

If you are not using the machine for more than a week, store the Tooling in a container and cover it with lubricant to prevent rust formation. If not, simply lubricate each part of the Tooling, particularly the heads and barrels of the Upper and Lower Punches, and reinsert it back into the machine.



LFA's Rotary Tooling Case provides storage and is perfect for transport and protection. Order at <https://www.lfatabletpresses.com/rotary-tooling-case>

Lubricating the Worm Reducer

The Worm Reducer's oil level mark is visible after opening the left-hand door panel. Apply #460 oil in winter and #680 oil in summer whenever it is dry.

Lubricating the Hydraulic Stem

The oil level should be at a depth of 5 mm with #22 turbine oil.

Lubricating the Spindle Bearing

Behind the back door panel is a pressure-oil injection ring. Add lithium grease lubricant to it.

Cover the HSTP®

Carefully cover the HSTP® with the plastic wrapping. You can use the plastic wrapping that came with the machine in the shipping container.

Environmental Conditions

It is important that the environment in which you store the HSTP® has the appropriate temperature and relative humidity levels. These two environmental factors can potentially cause the machine to rust and/or cause the tablets to have a lower quality. The table below shows the acceptable temperature and relative humidity levels:

Machine	Temperature		Humidity
	°C	°F	
HSTP® Range	18-24	64-75	45-65% RH

Appendix

Glossary

Term	Definition
API/Active Pharmaceutical Ingredient	Any substance or mixture of substances used that is an active ingredient in the drug product.
Binding agent	See excipient.
Die	The part of the Tooling that makes up the hole in which the powder is compressed and shaped into a tablet.
Die bore	The cavity inside the middle of the Die.
Die face	The very top flat surface of the Die.
Ejection height	The height at which the Lower Punch is lifted to for a tablet's ejection from the machine.
Excipient	An inactive substance that serves as the vehicle or medium for a drug or other API.
Fill depth	The amount of space that the powder can flow into in the Die.
Formulation	Powder mix of the excipient and the API that is compressed to make tablets.
Granular material	See Formulation.
Kilonewton (kN)	The force to accelerate a mass of 1 kg at a constant 1 m per second. The HSTP® range's pressure is measured in this unit.
Punches	The Upper Punch and Lower Punch have concave endings in the shape of the desired tablet. When the punches meet, they compress the powder between.
Punch pressure	The adjustable amount of force that is used to press tablets.
HSTP®	LFA trademarked term for high speed tablet press.
Tooling	Enables a tablet press to form tablets. It consists of Dies, Upper Punches, and Lower Punches.

Description of HSTP® Parts

Tooling

The Tooling consists of the Die, the Upper Punch, and the Lower Punch. This die set compresses the powder into the tablet. Order at <https://www.lfatabletpresses.com/products/tablet-press-tooling>

Feeder Tray Tail

The Feeder Tray Tail is an attachment that connects to the Force Feeder. The tail helps keep the powders inside the Die cavity right before being pressed, which allows for a more consistent tablet weight. Order at <https://www.lfatabletpresses.com/feeder-tray-tail-hstp>

Lower Punch Retainer Pins

These pins are design to hold the Lower Punches in place and to stop them from falling out during a Tooling change. They also assist in the travel of the Tooling around the lower tracking of the machine and over the ejection cams, ensuring that they do not take flight. Order at <https://www.lfatabletpresses.com/hstp-lower-punch-retaining-pins>



Perspex Cover for Ejection Chute

The Perspex Cover for the Ejection Chute is designed to fit all the machines in the HSTP® range. This part protects tablets from the moment of ejection from the Turret until they are stored inside the vessel being used to collect tablets. Order at <https://www.lfatabletpresses.com/hstp-perspex-cover-ejection-chute>



Upper Tracking Transition Block

The Upper Tracking Transition Block is used to hold the Upper Punches in place in the Turret. This is removed whenever the Tooling is changed. Although it is made from highly toughened steel and will likely never break, it can become lost during a Tooling change. Order at <https://www.lfatabletpresses.com/hstp-upper-tracking-transition-block-hstp>



HSTP Turret Change Set

The HSTP Turret Change Set is a full kit to change the Tooling to an option of D, B, or BB size. This kit includes a turret and all of the required cams. However, changing the turret is highly technical and should not be attempted without contacting LFA first. Order at <https://www.lfatabletpresses.com/hstp-turret-change-set>

Technical Specifications

	HSTP 26	HSTP 32	HSTP 40
Number of stations	26	32	40
Tooling specifications	Euro D	Euro B	Euro BB
Max output (tablets/h)	170,000	210,000	260,000
Max main compression (kN)	100	80	80
Max pre-compression force (kN)	20	20	20
Max tablet diameter - round (mm)	25	16	13
Max tablet diameter - shaped (mm)	25	18	16
Max fill depth (mm)	20	20	20
Max tablet thickness	6	6	6
Main motor power (kW)	7.5	7.5	7.5
Voltage frequency	3 phase 220 V or 380 V 50 Hz	3 phase 220 V or 380 V 50 Hz	3 phase 220 V or 380 V 50 Hz
Overall size (mm) LxWxH	1000 x 720 x 1868	1000 x 720 x 1868	1000 x 720 x 1868
Dimensions with suggested working clearance (mm)	1900 x 1620 x 2768	1900 x 1620 x 2768	1900 x 1620 x 2768
Weight	1750 kg / 3858 lbs	1900 kg / 4190 lbs	1900 kg / 4190 lbs

Maintenance Checklist

Before Operation	
<input type="checkbox"/>	Visually inspect the tablet press and the parts.
<input type="checkbox"/>	Ensure all locking nuts are tight.
<input type="checkbox"/>	Visually inspect grease nipples and regrease where necessary.
<input type="checkbox"/>	Tune the tablet press by hand to get the tablet size and weight correct.
<input type="checkbox"/>	Manually operate the machine to ensure it is not jammed.
During Operation	
<input type="checkbox"/>	Listen for irregular knocking or clicking sounds. If heard, stop operation and lubricate the machine's high-traction areas.
<input type="checkbox"/>	Watch for buildup of powder in front of the Force Feeder. If occurring, either (a) make mix more granular, (b) check the Force Feeder for damage, or (c) clear the buildup with a paintbrush.
<input type="checkbox"/>	Occasionally check the Motor's temperature. If it starts to overheat, turn off the machine, let it cool down, and grease it to ensure smooth operation.
<input type="checkbox"/>	Ensure that the Hopper does not run out of powder.
<input type="checkbox"/>	Weigh a sample tablet and test for its hardness.
After Operation	
<input type="checkbox"/>	Unplug machine and remove all excess powder with a bagless vacuum.
<input type="checkbox"/>	Remove the Tooling and Force Feeder and clean the inside of the tablet press.
<input type="checkbox"/>	Wipe down the other surfaces with a damp cloth.
<input type="checkbox"/>	Apply a layer of food grade grease to the entire machine.
<input type="checkbox"/>	Lubricate all grease nipples.
<input type="checkbox"/>	Store Tooling in an air-tight box with a small amount of grease.

Diagrams

HSTP® Dimensions

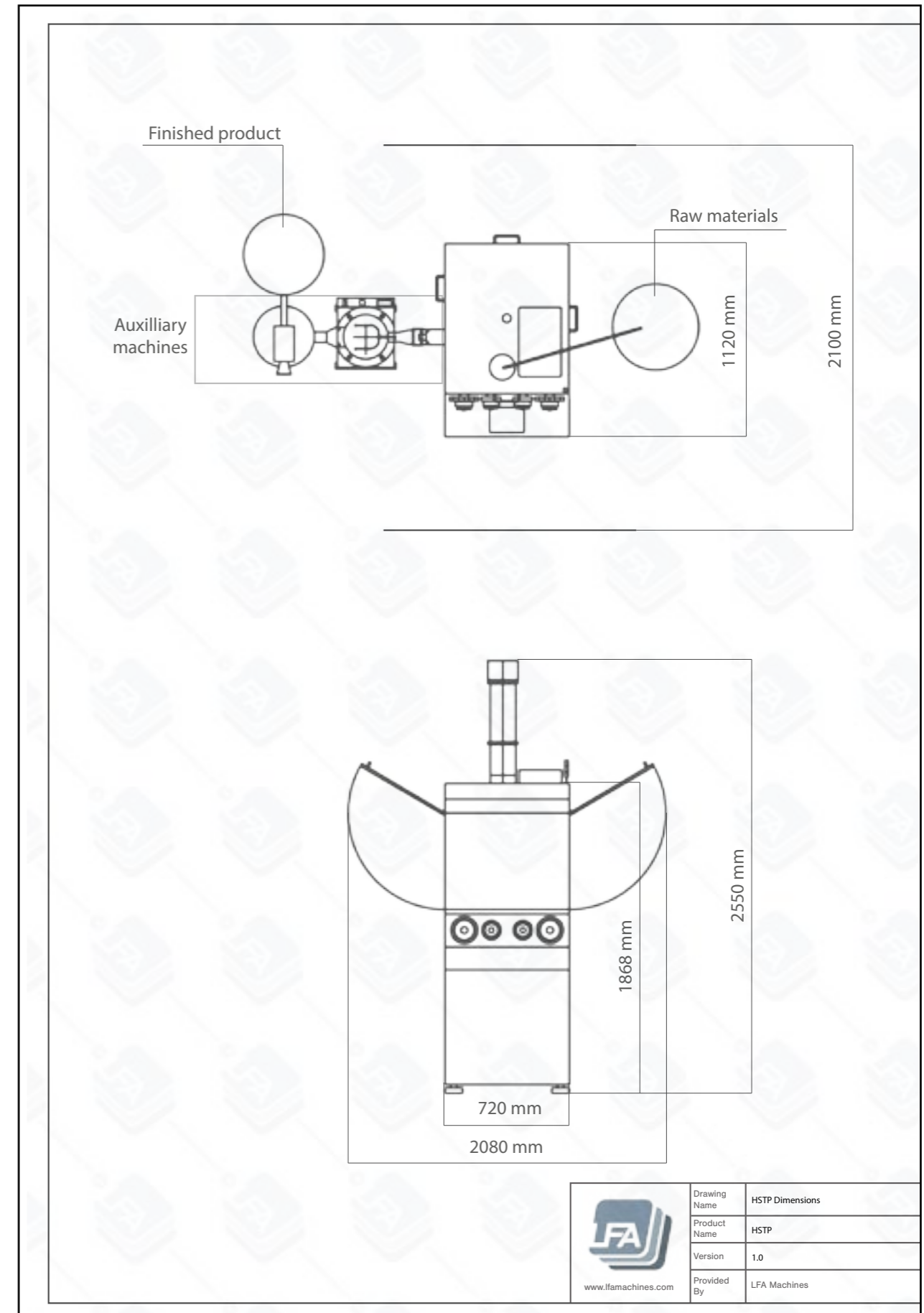

HSTP® Wiring Diagram 1

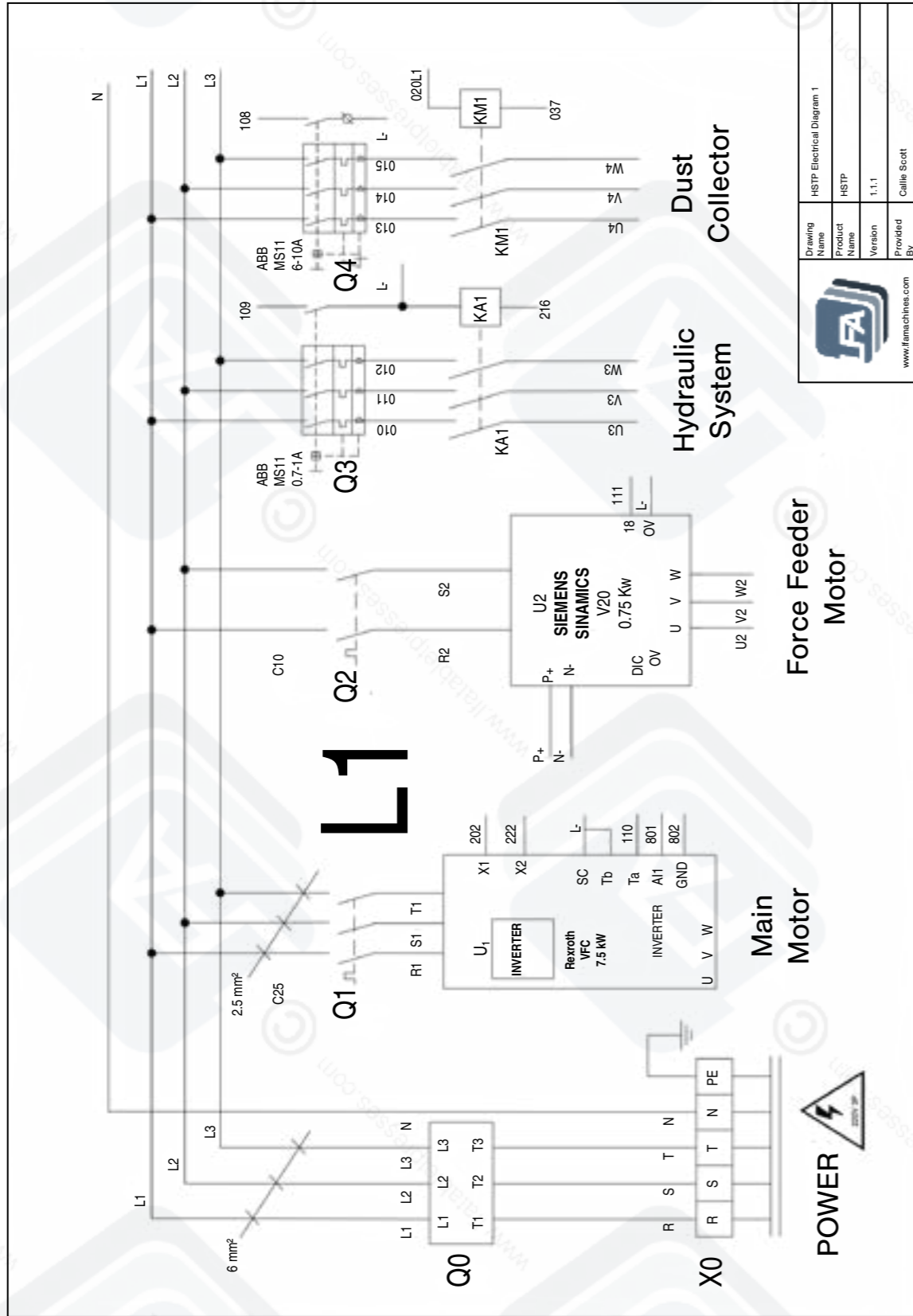

HSTP® Wiring Diagram 2

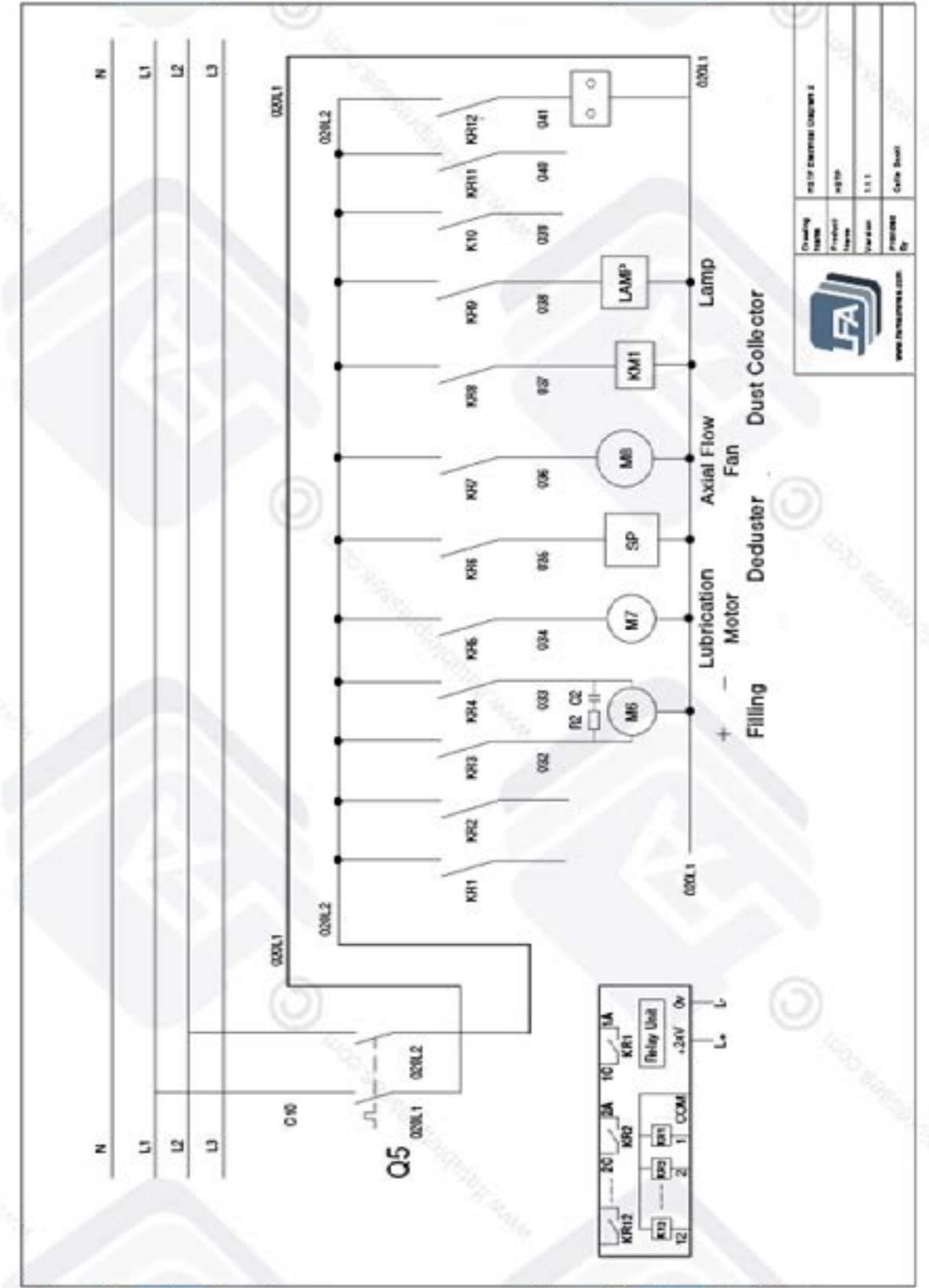

HSTP® Wiring Diagram 3

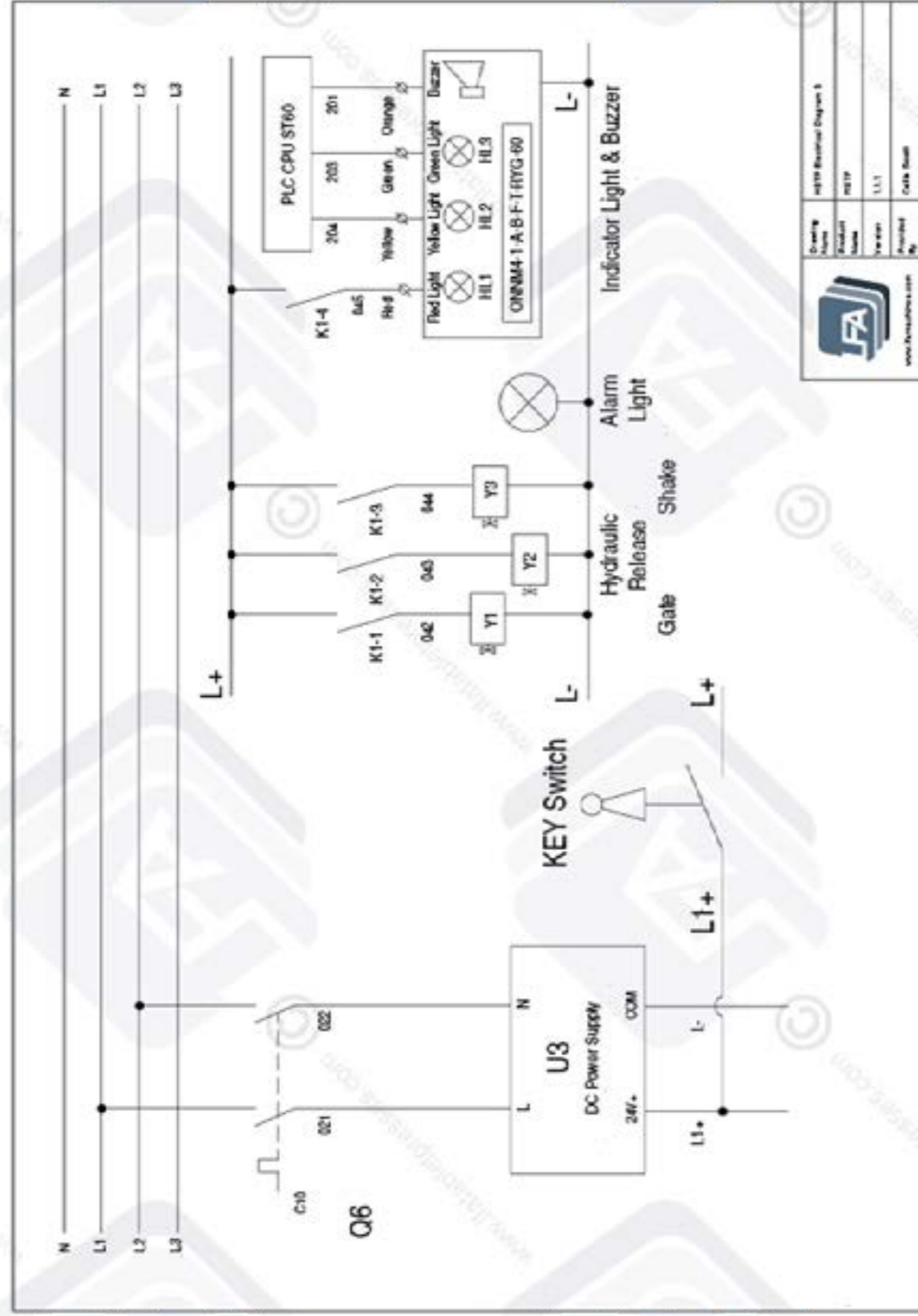

HSTP® Wiring Diagram 4

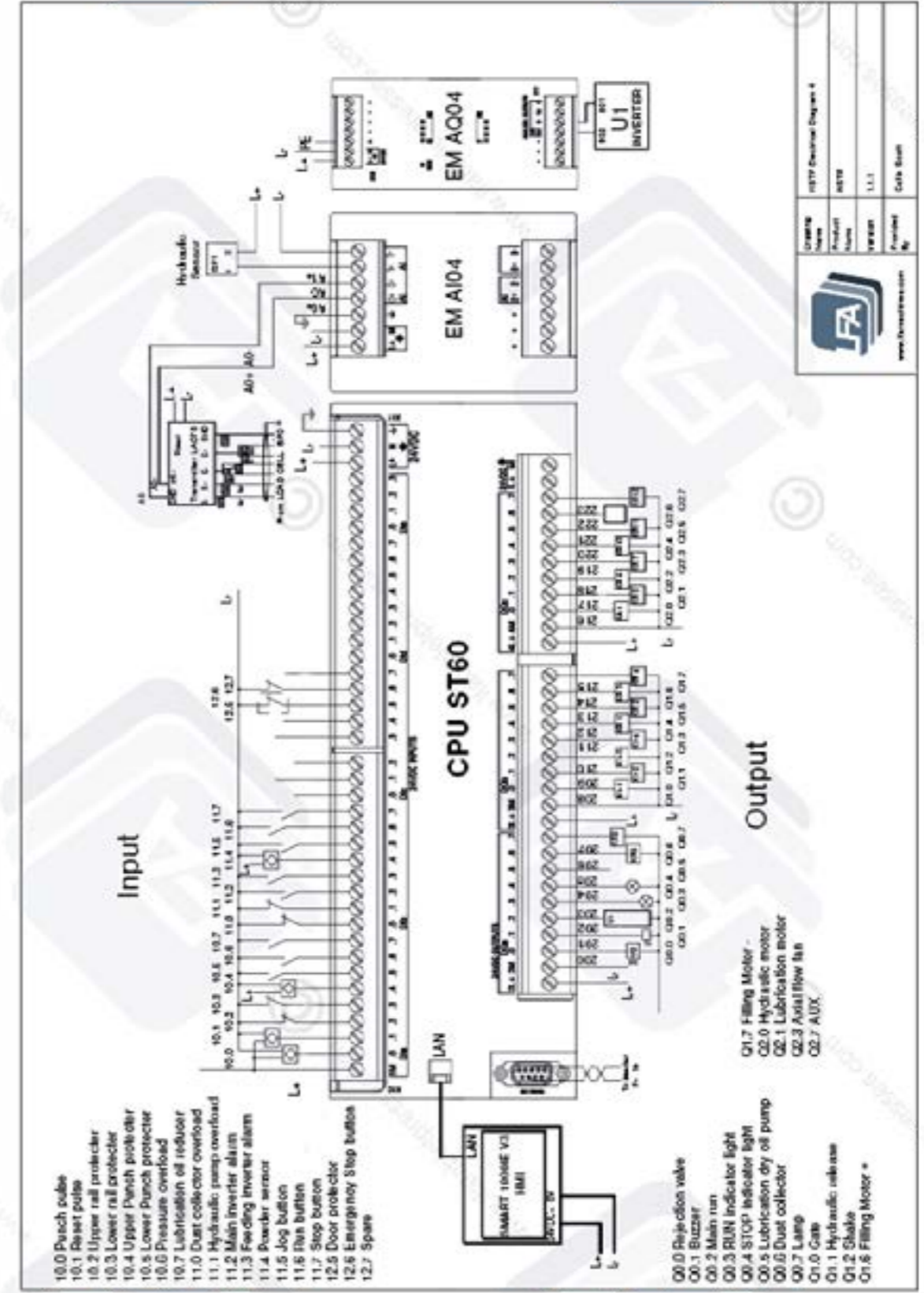

HSTP® Wiring Diagram 5

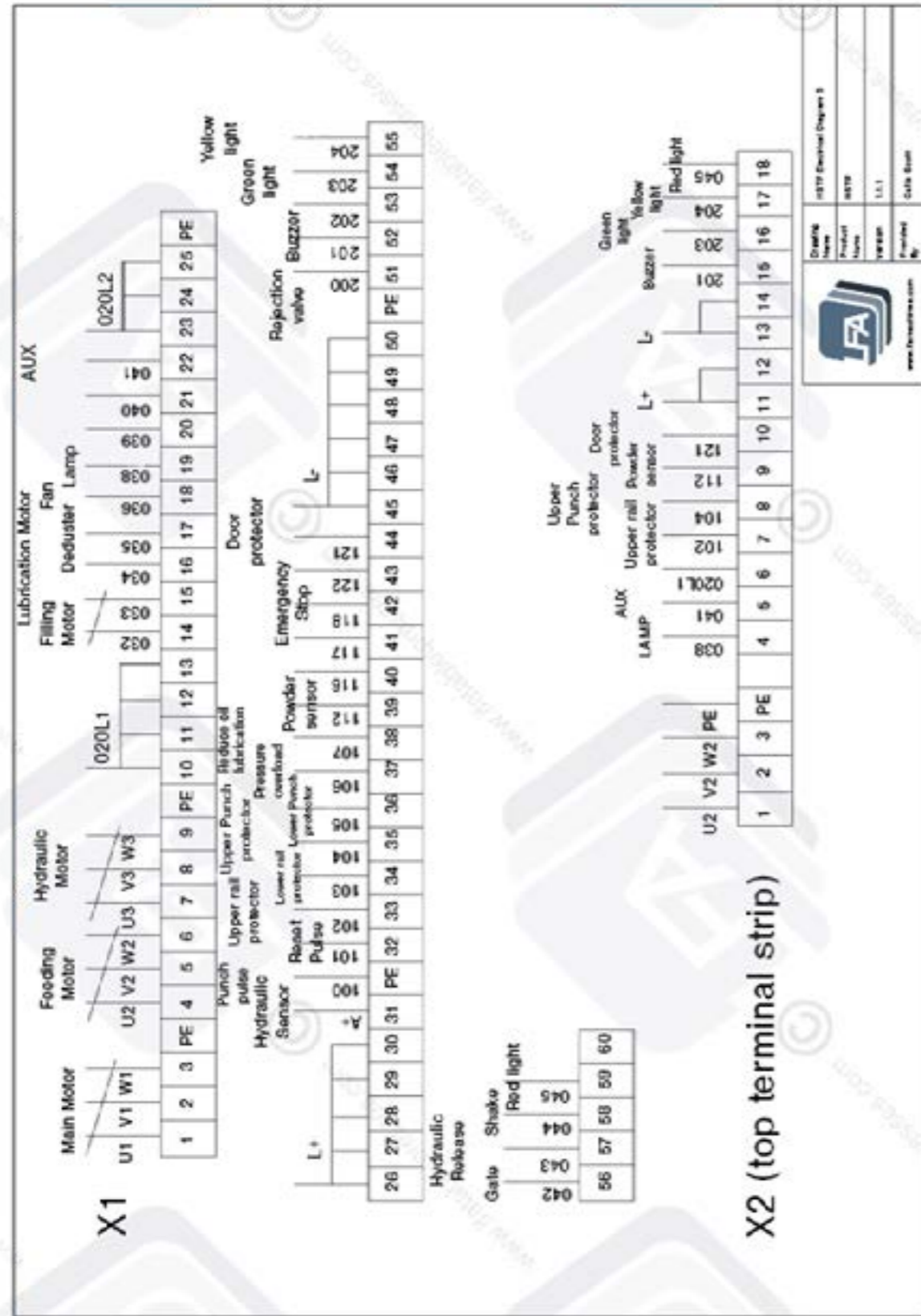

HSTP® Hopper Dimensions

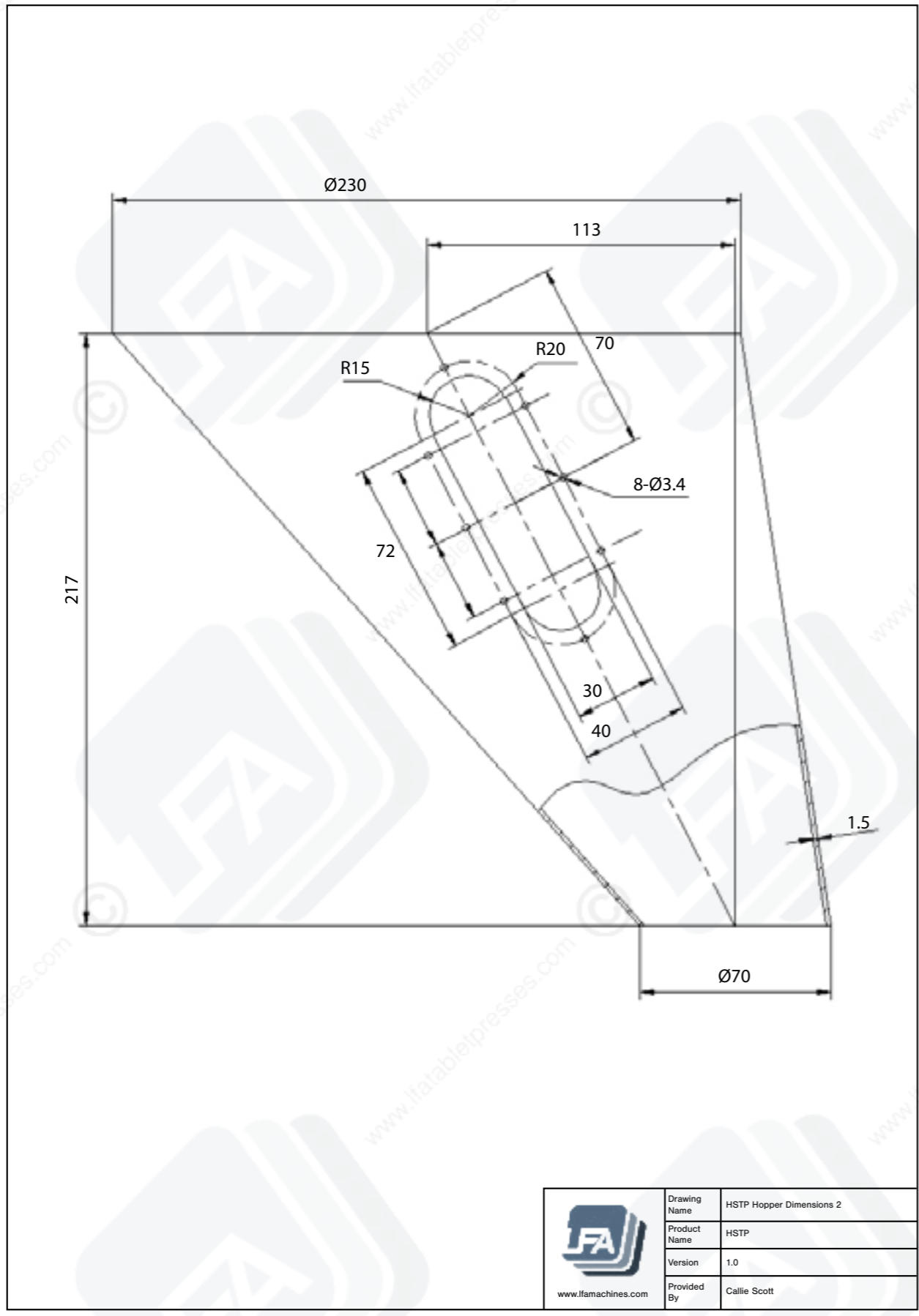

HSTP® Hopper Dimensions

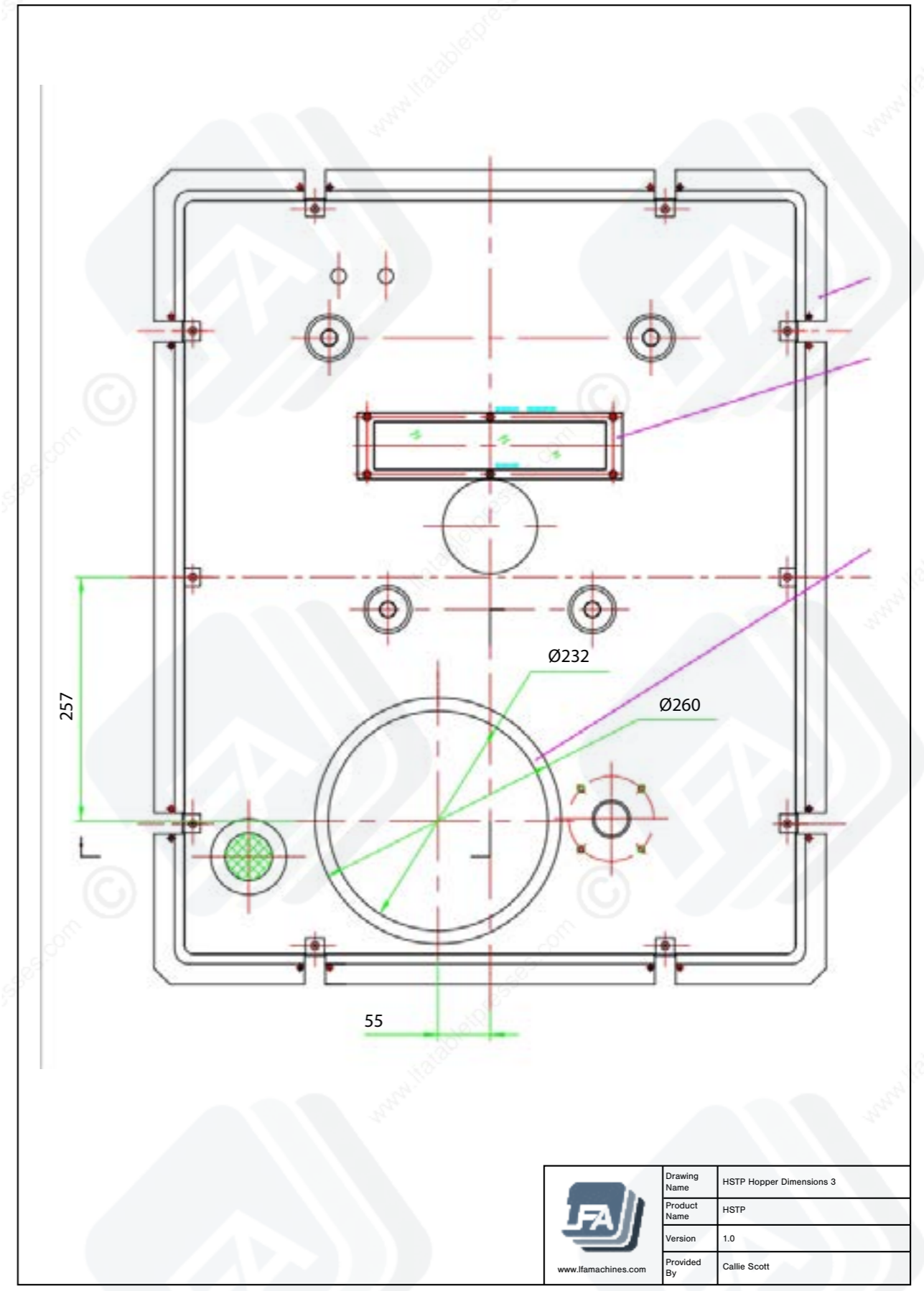

Resources

Helpful Links

Warranty

For information regarding the warranty policy of the HSTP® and other LFA products, please visit <https://www.lfatabletpresses.com/warranty>

LFA Website

In order to aid you in your tablet production, LFA Machines maintains a website that offers a breadth of useful information about the HSTP® and other tablet presses. Use our online tools such as the Tablet Mix Calculator to help you in your formulation production or read our regularly published articles that cover a whole range of topics about tablet presses and tablet production.

Visit the LFA homepage at <https://www.lfatabletpresses.com>

LFA Machines YouTube Channel

Our YouTube videos provide you an opportunity to see how to use our tablet presses, common troubleshooting tips, and other LFA products such as capsule fillers and mixers. We regularly upload videos to give you a visual aid that will hopefully support you in your tablet production efforts. To watch our videos, visit <https://www.youtube.com/channel/UCwtbcwja77ai7vX2o34FUkQ>

LFA Machines Social Media

Social media is a great way to keep yourself updated on new developments and exciting things happening at LFA Machines. The list below contains our current social media pages:

Twitter: @lfatabletpress

Instagram: @lfatabletpresses

Facebook: <https://www.facebook.com/lfatabletpresses>

LinkedIn: <https://www.linkedin.com/company/lfa-machines-oxford-ltd/>



LFA MACHINES

Contact Us

UK

LFA Machines Oxford Ltd
Unit 4B Rowood Estate
Murdock Road
Bicester, Oxfordshire OX26 4PP
+44 01869 250234
support.uk@lfamachines.com
Monday-Friday
9AM-5PM GMT

USA

LFA Machines DFW, LLC
6601 Will Rogers Blvd
Fort Worth, TX 76140
+1 (682) 312 0034
support.usa@lfamachines.com
Monday-Friday
8AM-6PM UTC (Central)

Germany

LFA Machines Düsseldorf GmbH
Business Parc Am Trippelsberg 92
Düsseldorf, North-Rhine
Westphalia 40589
+41 21188250223
verkauf@lfamachines.com

Taiwan

LFA Machines Taiwan Ltd
7F-5, No. 2, Sec. 2 Taiwan Blvd
West District, Taichung City 403
Taiwan
+886 422031790
support.asia@lfamachines.com
Monday-Friday
9AM-5PM GMT+8

Copyright © 2021 by LFA Machines

www.lfamachines.com

United Kingdom

Unit 4B
Murdock Road
Bicester
Oxfordshire
United Kingdom
OX26 4PP

United States

6601 Will Rogers Blvd
Fort Worth
Texas
United States
76140

Germany

Business Parc Am
Trippelsberg 92
Düsseldorf
Germany
40589

Taiwan

7F-5, No. 2, Sec. 2
Taiwan Blvd., West Dist.,
Taichung City 403,
Taiwan