

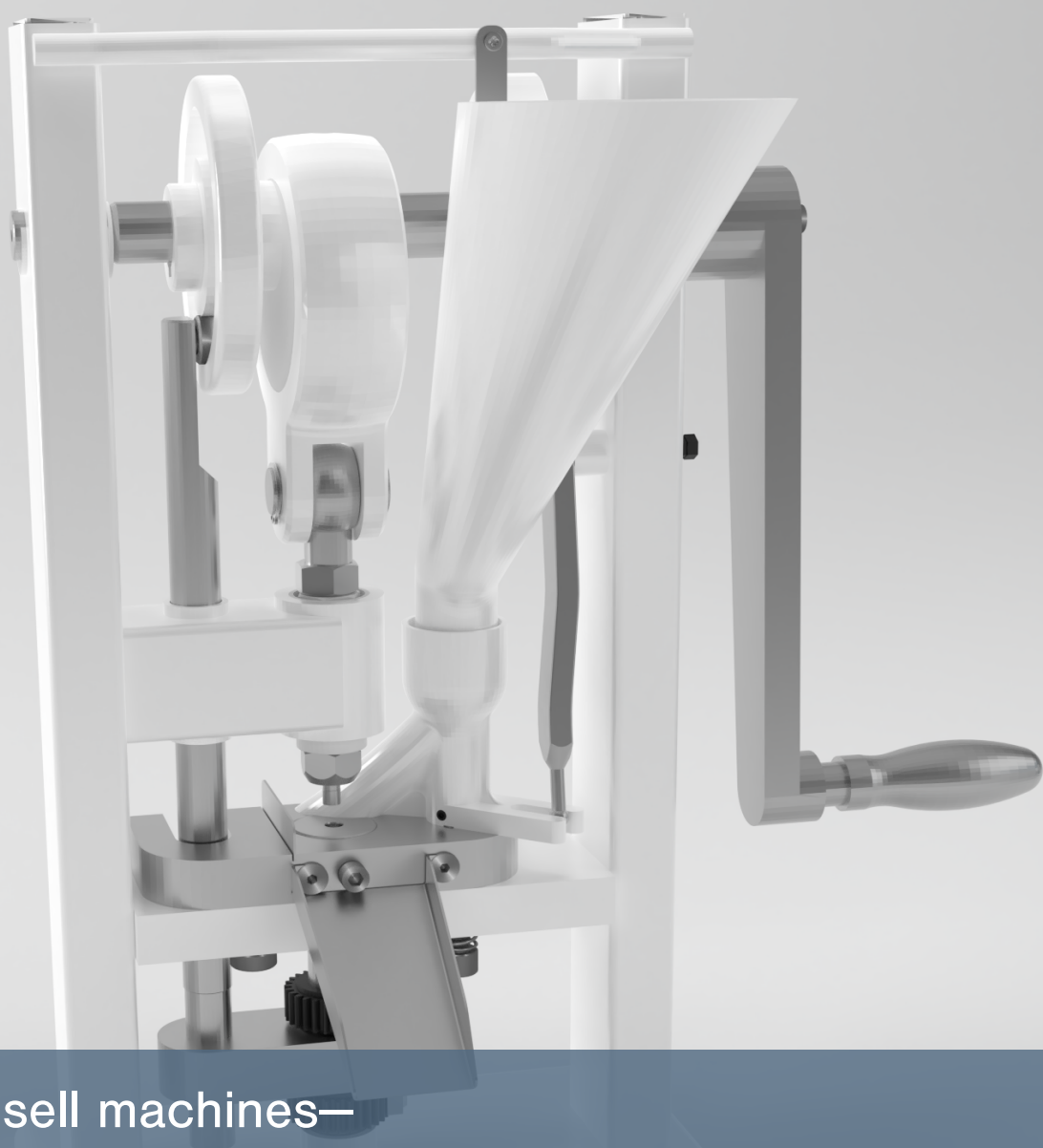

TDP 0[®] Tablet Press User Manual



We don't just sell machines—
we provide service.

Copyright Notice

© LFA Machines Oxford Limited, published in 2022 by LFA Machines Oxford Limited 2022. Registered in England and Wales, company number 08428898, registered office for service Demar House 14 Church Road East Wittering, Chichester, West Sussex, PO20 8PS.

All rights reserved. No part of this publication may be reproduced or transmitted, in any form or by any means, or stored in any retrieval system of any nature, without prior permission, except for fair dealing under the Copyright, Designs and Patents Act 1988, or in accordance with the terms of license issued by the Copyright Licensing Agency in respect of photocopying and/or reprographic reproduction. Application for permission for other use of the copyright material including permission to reproduce extracts in other published works shall be made to the publisher. Full acknowledgment of author, publisher and source must be given.

All trade marks are acknowledged and are owned by their respective owners.

Important Safety Information

READ THIS BEFORE OPERATING MACHINE

Intended Use

The intended use of this machine is to press dry raw materials into tablet form.

Potential misuse of this machine includes:

- Applying too much force to the powder.
- Trying to fill the Die with powder by hand.
- Inserting Tooling that is too big for the machine.
- Not properly mounting the machine.
- Using powders that could explode under pressure.
- Using wet or damp material.

General Hazards

- Be aware of risk of entanglement and pinch points due to moving parts.
- Keep out of reach from children.
- Keep fingers away from all moving parts.
- Ensure that the machine is secured to a workbench to prevent it falling.
- Inspect machine before use.
- Check that nuts and bolts are suitably tightened.
- Use this machine only for its intended use as described in this manual.
- Do not modify the machine in any way.

Personal Protection

For personal protection while transporting the TDP 0[®]:

- Wear steel toe boots to prevent foot injury.
- Wear heavy duty grip gloves to ensure firm grasp on machine.
- Wear back support belt to prevent injury if needed.

For personal protection while operating the TDP 0[®]:

- Avoid wearing loose jewelry to prevent machine entanglement.
- Contain long hair to prevent machine entanglement.
- Wear safety goggles.
- Wear disposable latex/rubber gloves.
- Wear a hairnet (food grade products only).
- Wear a beard net if needed (food grade products only).

Important Safety Information

READ THIS BEFORE OPERATING MACHINE

Symbols



CAUTION

This signals potential risk for damage to the machine or other parts.



WARNING

This signals potential risk for personal injury.

Modes for Stopping

In the case of an emergency, immediately stop turning the Handle and remove yourself from the TDP 0[®].

Prop. 65 Statement for CA Residents

Based on LFA's current level of knowledge of our machines, the TDP 0[®] does not require a Proposition 65 warning label.

Warning for Explosive Material

This machine is not explosion proof. LFA recommends that you test your materials' explosivity before running them through this machine. If your materials are indeed explosive, do not use them with this machine.

Important Safety Information

READ THIS BEFORE OPERATING MACHINE

Installation and Safety Assessment

Due to the nature and design of this machine and its intended use in an industrial environment, it is important that before use it is installed in a cage with a mode of stopping on the outside of the cage. LFA Machines has decided that we can not possibly foresee all of the environments or situations in which this machine could be used or installed and therefore have determined that the end user must install the machine in a way that is appropriate and safe for its use.

Once the machine has been installed, it is critical that you conduct a safety assessment to ensure that it complies with all local and industry accepted safety regulations.

If you require guidance on the installation of the machine or conducting a safety assessment, please contact LFA Machines.

This machine is sold as an Unfinished Machine under the Machinery Directive (2006/42/EC) Article 13.

Table of Contents

Copyright Notice	2
Important Safety Information	3
Intended Use	3
Personal Protection	3
General Hazards	3
Symbols	4
Modes for Stopping	4
Prop. 65 Statement for CA Residents	4
Warning for Explosive Material	4
Installation and Safety Assessment	5
TDP 0[®] Components	7
TDP 0[®] Parts List	8
Preface	9
Training	10
Off-Site Training	10
Training via Video Chat/Phone	10
LFA Articles	10
LFA Videos	10
Installation	11
Tools and Materials Needed	11
The Appropriate Workstation for the Machine	11
Assembly	14
Mounting the TDP 0 [®]	14
Manual Controls	16
Settings and Adjustment	19
Maintenance	26
General Maintenance Prescriptions	26
Lubrication	26
Dismantling for Repair and Replacement	29
Wear Parts and Causes of Damage	29
Tooling	30
Boot Timing Bar	37
Boot	40
Upper Drift Pin Assembly	43
Upper Drift Pin Assembly Rod Eye and Clevis	51
Lower Drift Pin Assembly	60
Troubleshooting	68
Common Machine/Part Issues	68
Common Tablet Issues	70
De-jamming the TDP 0 [®]	71
Cleaning	73
Storing and Transporting the TDP 0 [®]	83
Appendix	89
Glossary	89
Description of TDP 0 [®] Parts	90
Material of Contact Parts	95
Technical Specifications	95
Maintenance Checklist	96
Diagrams	97
Resources	101

TDP 0[®] Components

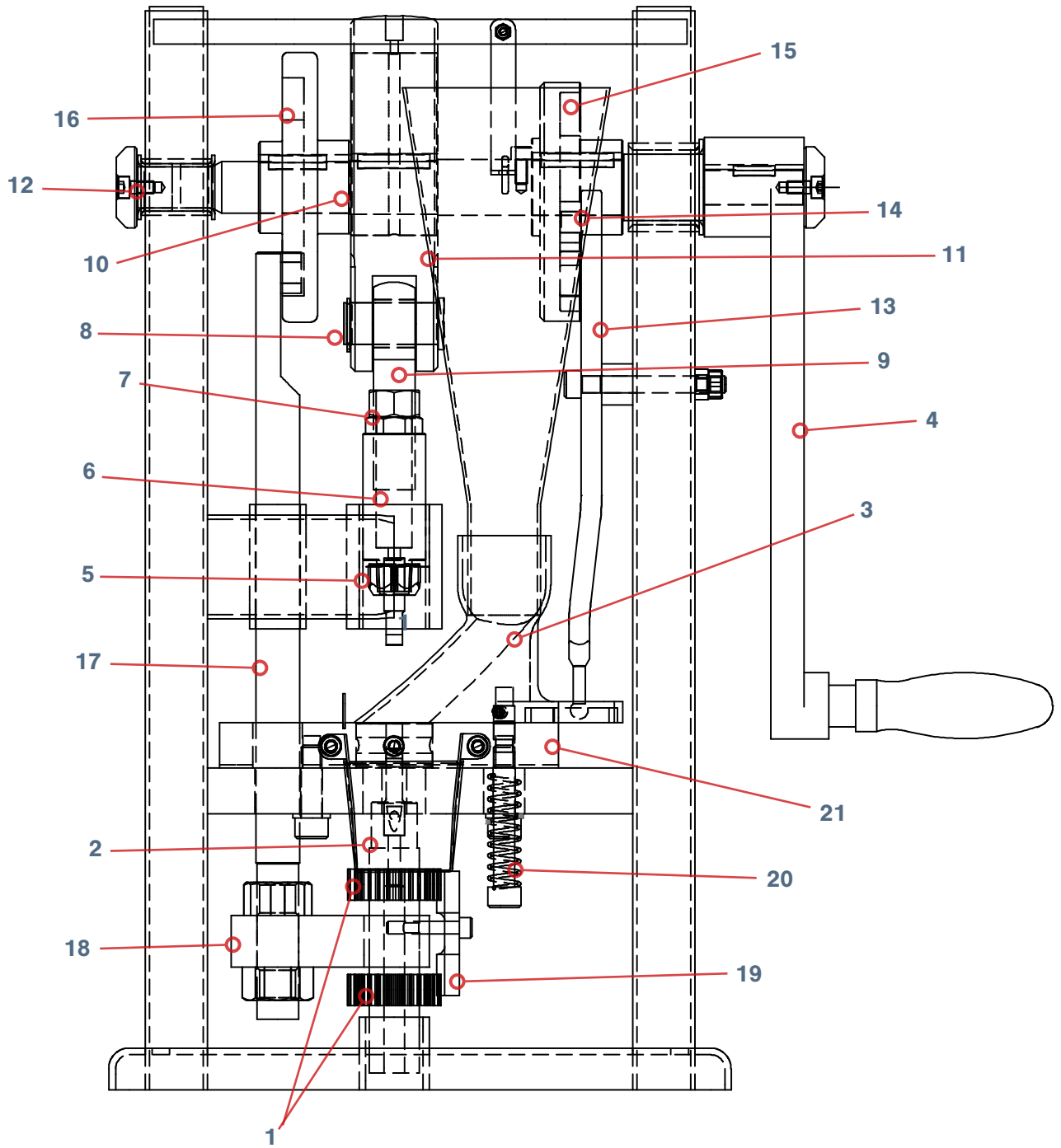

TDP 0[®] Parts List

1. Lower Drift Pin Assembly Cogs (#AEC0012)
2. Lower Drift Pin Assembly (#AEC0011)
3. Boot (#AEC0036)
4. Handle (#ACC0010)
5. Upper Punch Locking Nut (#AEC0003)
6. Upper Drift Pin Assembly (#AEC0002)
7. Upper Drift Pin Assembly Locking Nut (#AEC0006)
8. Eccentric Sheave Connecting Pin (#AEC0001)
9. Upper Drift Pin Assembly Rod Eye and Clevis (#AEC0005)
10. Eccentric Sheave (#ACC0005)
11. Eccentric Sheave Strap (#AEC0004)
12. Top Cam Drive Shaft (#ACC0006)
13. Boot Timing Bar (#AEC0018)
14. Boot Timing Drive Bar Runner (#AEC0020)
15. Boot Timing Cam (#ACC0004)
16. Lower Drift Pin Assembly Timing Cam (#ACC0001)
17. Lower Drift Pin Assembly Timing Rod (#ACC0002)
18. Lower Drift Pin Assembly Lifting Bar (#AEC0034)
19. Lower Drift Pin Assembly Locking Bar (#AEC0013)
20. Boot Bolt and Spring (#AEC0051)
21. Base Plate (#AEC0008)

Preface

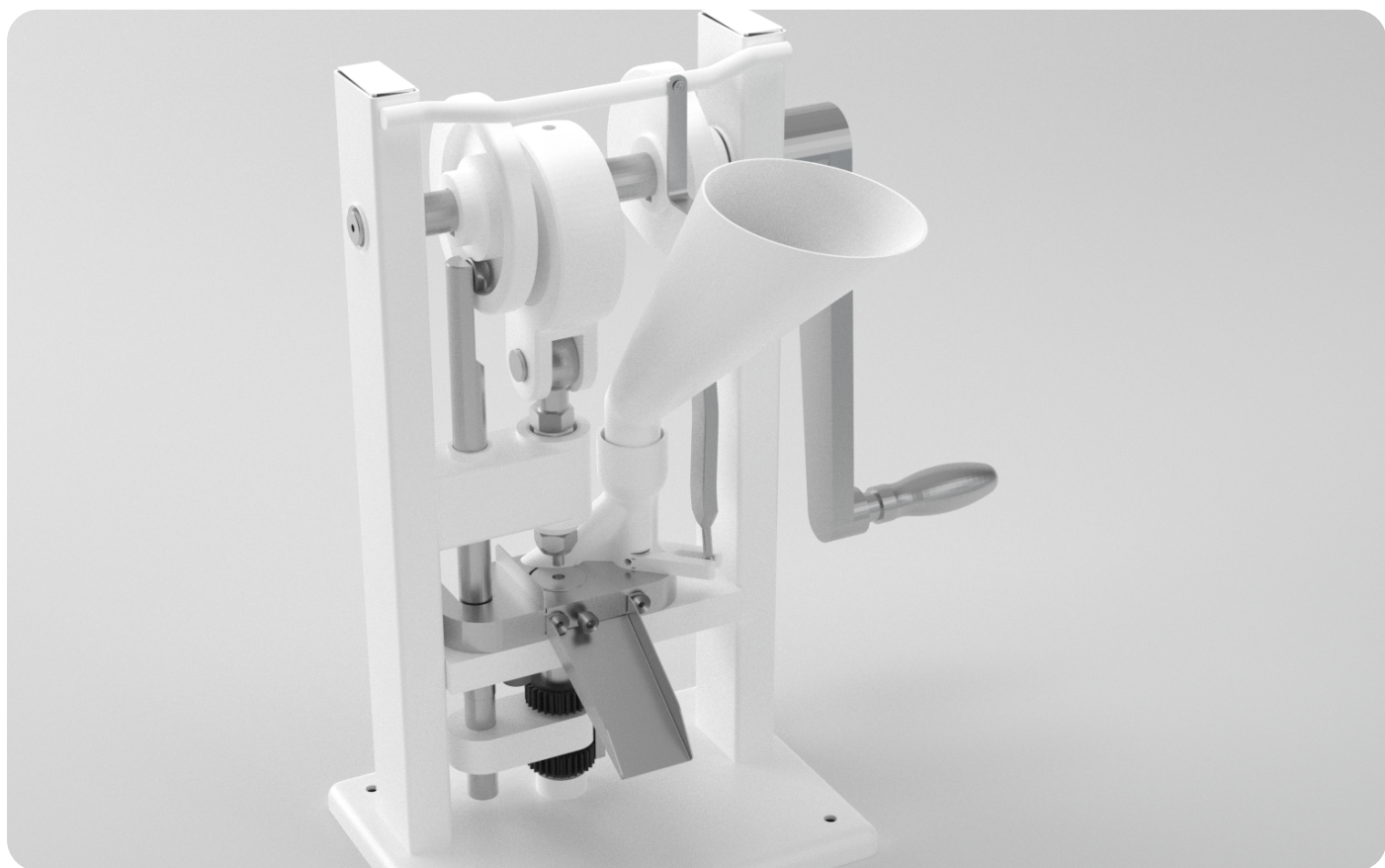

The TDP 0[®] Tablet Press is a manually operated pill press that has the ability to produce small quantities of tablets (up to 12 mm in diameter and 6 mm thick) from a powder formulated with dry granular materials and an excipient. Without an external power source, the TDP 0[®] can press up to 40 tablets a minute with interchangeable dies. Useful for work in the field and on location, the TDP 0[®] is popular with a range of users, including hospitals, research facilities, and laboratories in the pharmaceutical, food, and chemical industries. This small, lightweight desktop tablet press is simple to operate and maintain.

The purpose of this document is to support your understanding of the TDP 0[®]'s components, features, functions, and design. With this manual, you will be able to successfully operate and maintain your TDP 0[®] machine.

The user manual's content includes:

- Important safety information
- TDP 0[®] installation instructions
- Description of the TDP 0[®]'s operation
- TDP 0[®] maintenance information
- Appendix with supplemental information

Training

TDP 0 training is essential for the machine's successful operation and your personal safety. There are several methods to prepare you for working with the TDP 0®.

In-Person Training

LFA offers free training at our UK, USA, and Taiwan facilities for all our customers and their teams. For more information, go to <https://www.lfatabletpresses.com/services>.

Training via Video Chat/Phone

Using an online video chat system, an LFA technician can interact face-to-face with you and assist with your understanding of the machine. Or, if you prefer, LFA can provide training via phone for all customers who call the office. To set up a training, call or email your local LFA office:

UK

Phone

+44 01869 250234

Email

support.uk@lfamachines.com

USA

Phone

+1 (682) 312-0034

Email

support.usa@lfamachines.com

Taiwan

Phone

+886 4225031790

Email

support.asia@lfamachines.com

LFA Articles

LFA writes informative articles about desktop tablet presses, which includes instructions, procedures, and guides.

To access the articles, go to <https://www.lfatabletpresses.com/articles>.

LFA Videos

LFA has created several videos involving the TDP 0® and other desktop tablet presses.

To access the videos, go to <https://www.lfatabletpresses.com/videos> or <https://www.youtube.com/user/TabletPilPress>

Installation

Tools and Materials Needed

Before you install and operate the TDP 0[®], it is best to have the following tools and materials on hand for general operation and maintenance:

- Four nuts and M6 bolts with length to accommodate the 24 mm base and the thickness of the workspace surface
- Power drill
- Hammer
- Rubber mallet
- Metric wrench set
- Circlip pliers
- Pliers/grippers
- Crosshead screwdriver
- Set of metric Allen keys with ball ends
- Long wire pipe cleaner
- Lubricant (FG type for food grade products)
- Grease gun
- Toothbrush
- Cleaning brush set
- Plastic sheet or something similar to cover machine
- Safety goggles
- Disposable latex/rubber gloves
- Hairnet and/or beard net (food grade products only)
- Sterile shoe covers (food grade products only)

The Appropriate Workstation for the Machine

Find a stable workspace surface that supports the TDP 0[®]'s 21 kg (about 48 lbs) weight, such as a wooden bench (use stainless steel if for food grade industry). Another important thing to consider is to find a bench that has a suitable working height for you.

Environmental Conditions

It is important that the environment in which you operate and store the TDP 0[®] has the appropriate temperature and relative humidity levels. These two environmental factors can potentially cause the machine to rust and/or cause the tablets to have a lower quality. The table below shows the acceptable temperature and relative humidity levels:

Machine	Temperature		Humidity
TDP 0 [®]	°C	°F	45-65% RH
	18-24	64-75	

The shipping crate will contain the following:

1. The assembled TDP 0®

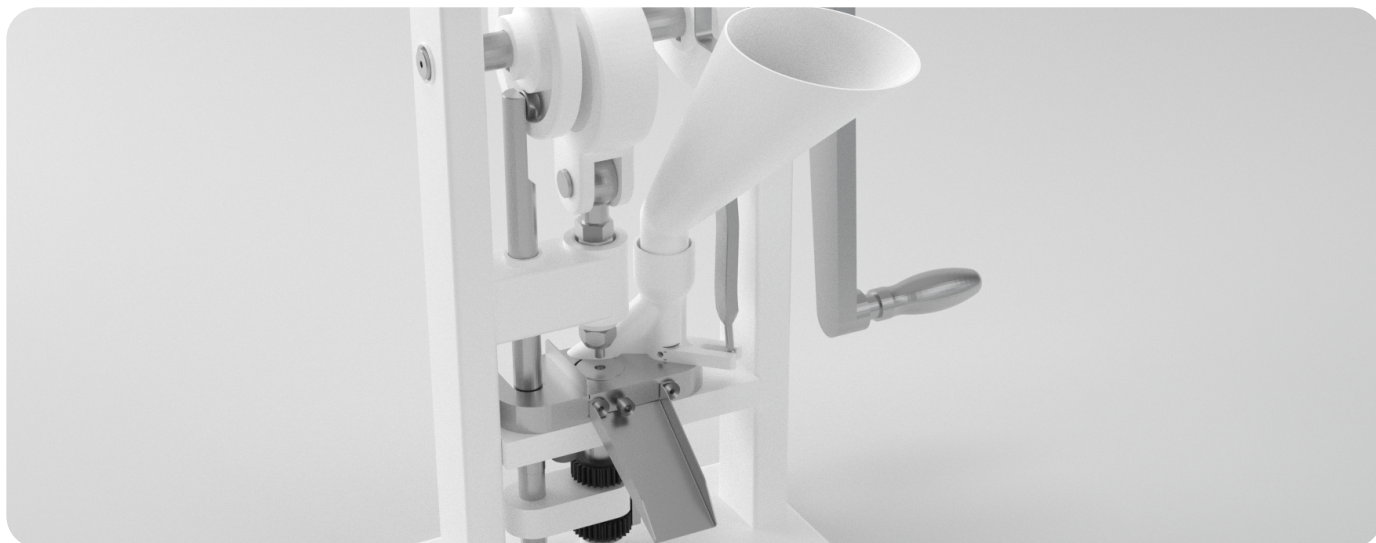

2. The Tooling (already installed)

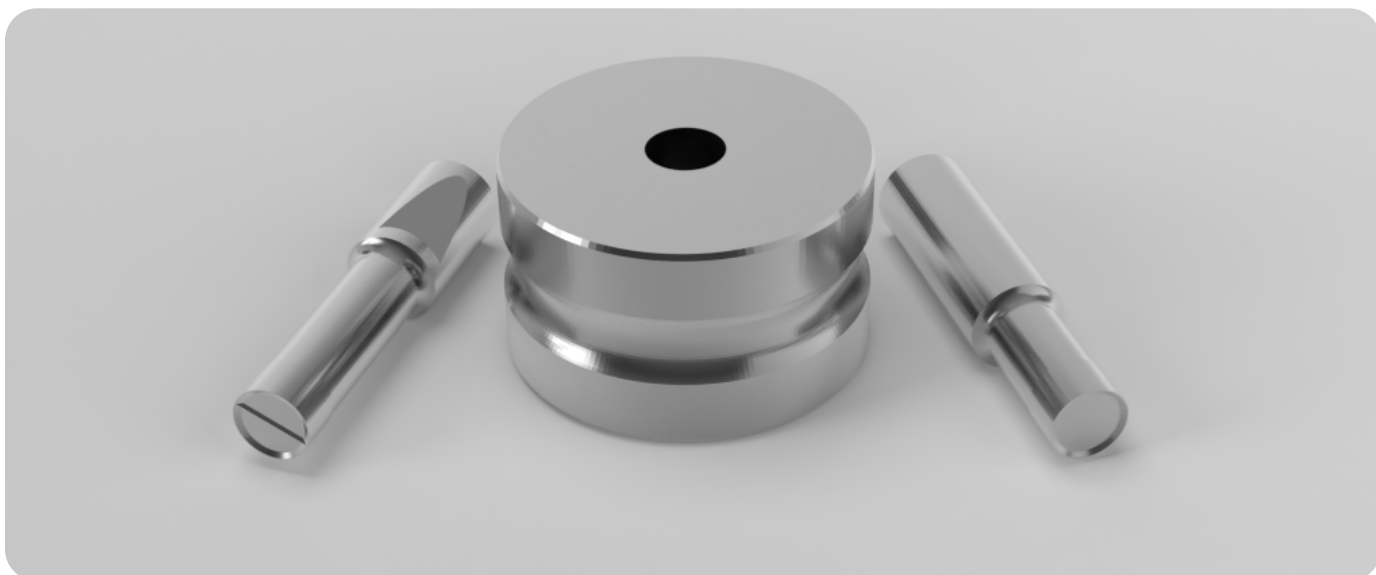

3. The Hopper

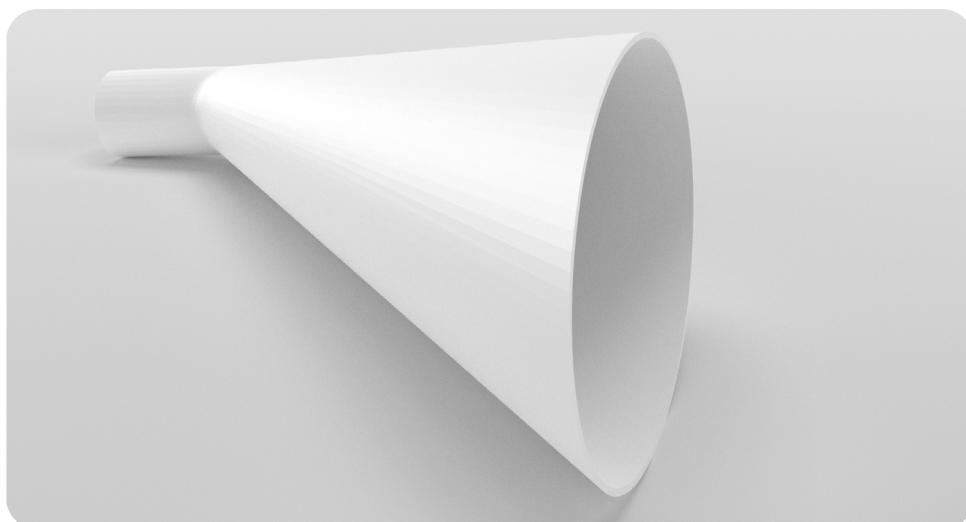

Unpacking the TDP 0®

Watch a video of a TDP 0® unboxing at <https://www.lfatabletpresses.com/videos/tdp-0-unboxing-setup>

Tools Needed

- Crosshead screwdriver

Instructions

1. Remove the screws on the bottom of the shipping container with a crosshead screwdriver.



1.1 Note: Keep the screws and the shipping container in case you need to return the TDP 0®.

2. Lift the top of the shipping container from its base, which is bolted to the TDP 0®.
3. Remove the plastic wrapping and set the Hopper aside.

3.1 Note: Save the wrapping for future transport and/or storage.

4. Unscrew the TDP 0® from the shipping container's base with a crosshead screwdriver.



4.1 Note: Keep the screws and the shipping container's base in case you need to move or relocate the TDP 0®.

Assembly

The TDP 0[®] comes almost fully assembled. For shipping purposes, the Handle is delivered installed on the opposite side of the arm. Simply unscrew the Handle by hand and install it on the correct side of the arm. Then, insert the Hopper into the Boot like so:

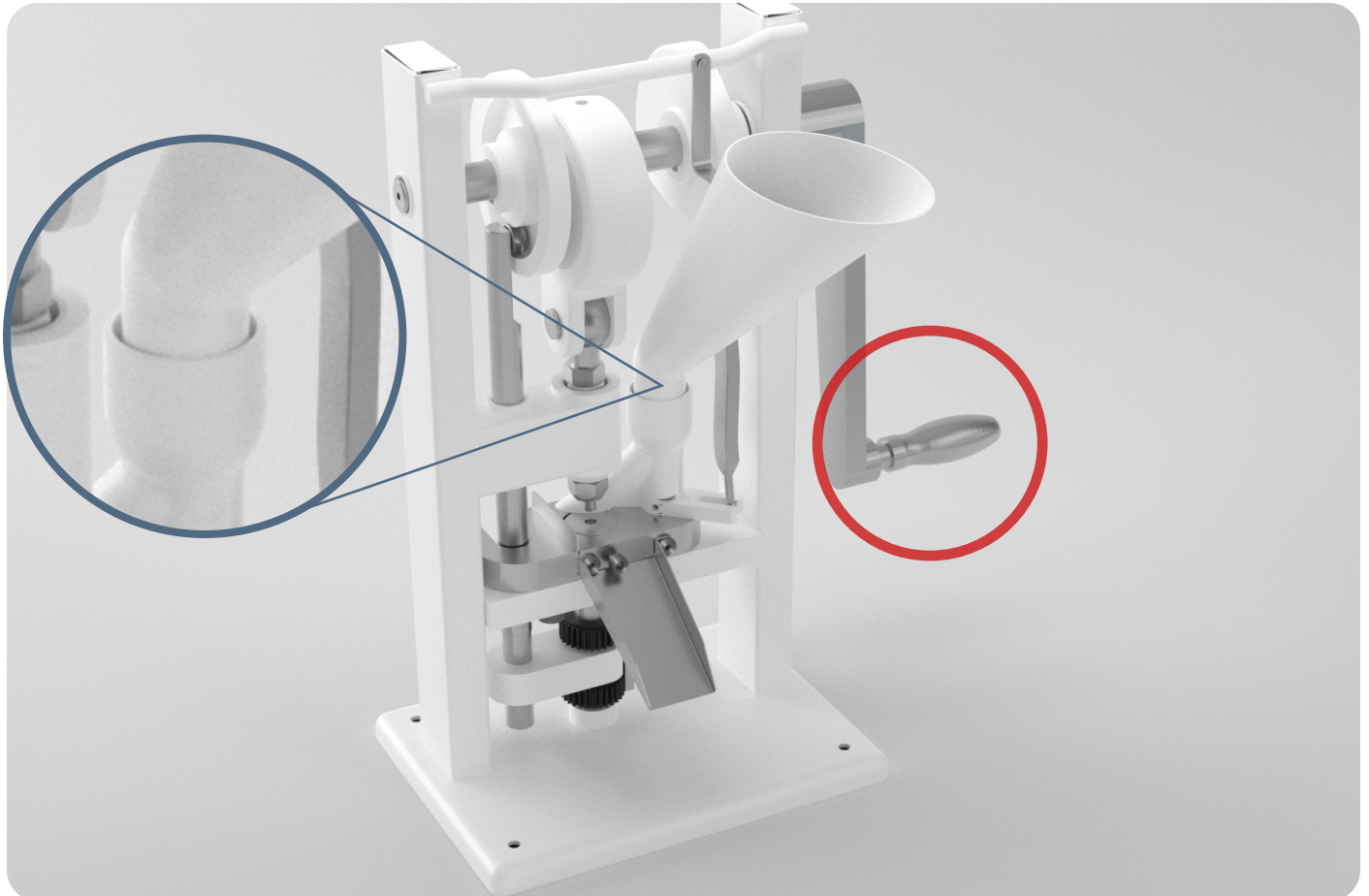

Mounting the TDP 0[®]

WARNING: To prevent personal injury, wear steel toe boots and heavy duty grip gloves while transporting the TDP 0[®].



One or two people should be sufficient in removing the machine from the shipping container and placing it in the workspace.

To safely transport the TDP 0[®], grab both the Handle at the top and the bottom of the TDP 0[®] Base for support.

The TDP 0[®] Base comes with four bolt holes. Because its movement could cause the TDP 0[®] to fall off the workspace surface during operation, which creates potential for injury to self and to the machine, it is important to bolt it onto the workspace surface.

Tools and Materials Needed

To secure the TDP 0[®], you need four nuts and bolts (M6 with >24 mm length) and a power drill that can drill holes into your workspace surface. The size of the bolts depends on your workspace surface's diameter. To give you a better idea of this, here is a picture of a desktop tablet press on top of a workspace surface:

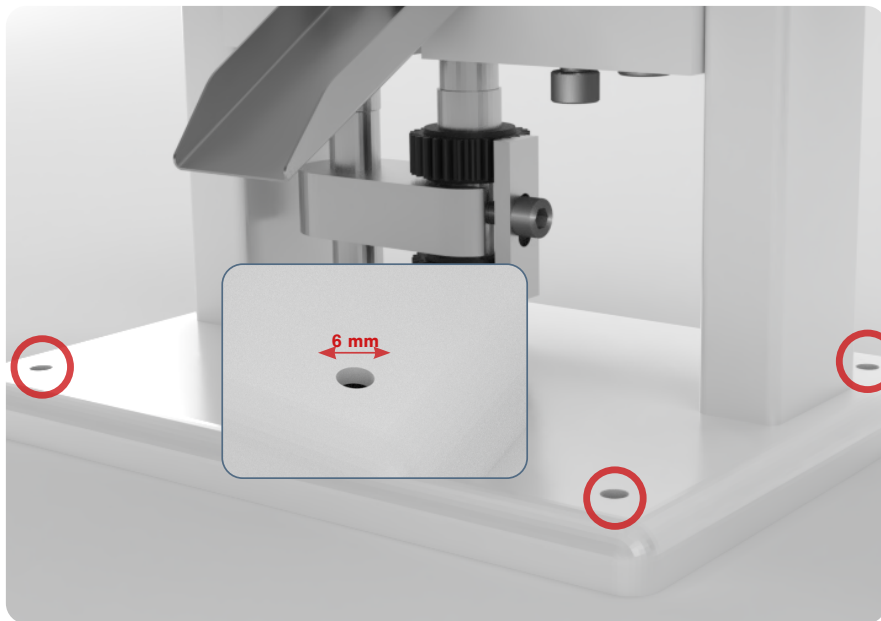

To assist you in drilling, it might be helpful to print out a template, which can be found in the Appendix, as a reference for where you want the bolt holes to be.

In accordance with Article 13 of the European Directive 2006/42/EC, LFA Machines sells the TDP 0[®] as a partly finished machine, and it is meant to be installed into and function as a part in a production line.

After the installation of this machine, the following measures need to be taken:



- **Shields must be installed in order to cover moving parts, those being in particular the Upper Punch, Upper Drift Pin Assembly, Lower Drift Pin Assembly, Boot, and Top Cam Assembly.**
- **An emergency stop/emergency lockout/isolator switch must be installed on the outside of the machine.**
- **A risk assessment must be conducted on the entire production line.**

If you require guidance on the installation of the machine or conducting a safety assessment, please contact LFA Machines.

Manual Controls

Basic Components

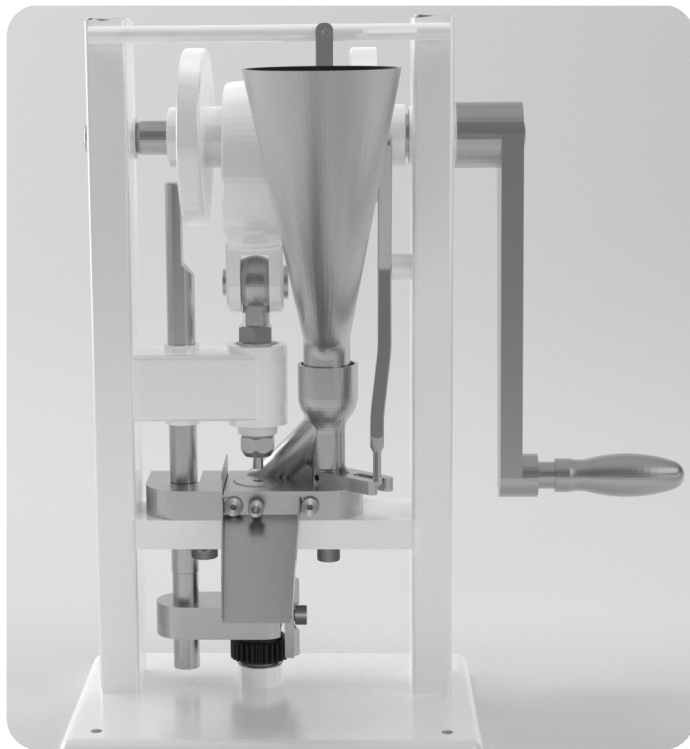

Front

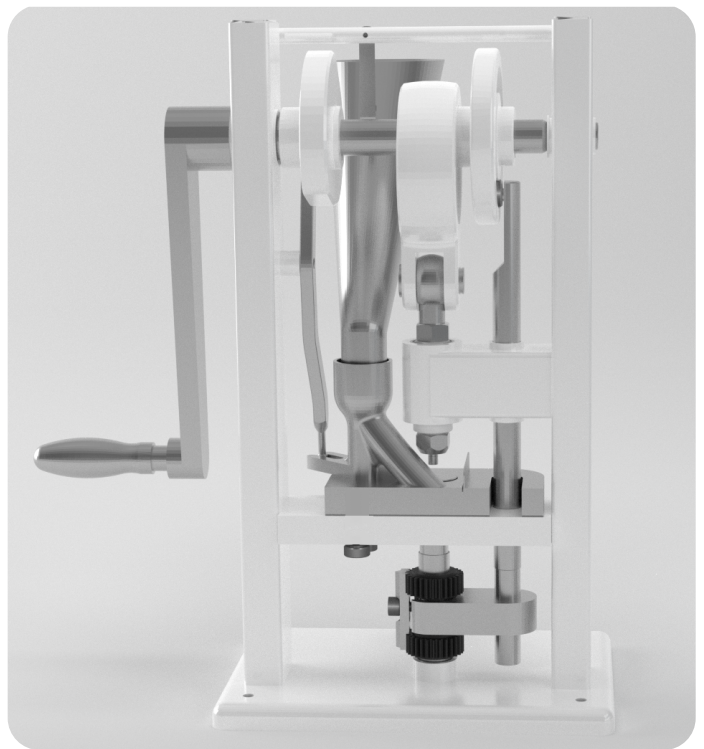

Back

A description of the principal components follows:

- The **Handle** is connected to the Arm, which you turn to start the cam track's direction.
- The **Top Cam Drive Shaft** guides the punches' movement.
- The **Hopper** holds the dry materials that will be compressed.
- The **Boot** moves the materials from the Hopper to the Tooling and ejects the tablets.
- The **Die** defines or molds the size and shape of the powder.
- The **Upper Punch** and **Lower Punch** compress the materials within the Die.

TDP 0[®] Process

The basic mechanism of the TDP 0[®] involves filling the Tooling (Die, Upper Punch, and Lower Punch) with powder, compressing the powder, and ejecting the tablet.

Filling the Tooling with Powder

The dry materials are poured into the Hopper, which funnels the powder into the Boot. As the Hand Wheel is manually operated, the Top Cam Drive Shaft withdraws the Upper Punch from the Die.

Compressing the Powder

After the powder is filled in the Tooling, the Top Cam Drive Shaft drives the Upper Punch into the Die, which creates high pressure between both punches that allows the tablet to be compressed.

Ejecting the Tablet

After both punches compress the powder into a tablet, the Top Cam Drive Shaft withdraws the Upper Punch while the Lower Punch is pushed upward to expel the tablet. The tablet is then pushed out of the way by the Boot to prepare for the next tablet compression.

How to Create Tablets with the TDP 0[®]

Tools and Materials Needed

- Raw material formulation
- Fully assembled TDP 0[®] with Hopper
- Safety goggles
- Disposable latex/rubber gloves (for food grade products and to protect hands from grease)
- Hairnet and/or beard net (food grade products only)
- Sterile shoe covers (food grade products only)



WARNING: For personal protection while operating the TDP 0[®], contain long hair and do not wear loose jewelry. To avoid injury, do not turn the Handle while you are collecting tablets.

Instructions

Note: Wear latex/rubber gloves (and appropriate food grade attire if applicable) during this process.

1. Adjust the fill depth and punch pressure to the lowest level.
2. Pour the dry materials into the Hopper.
3. Rotate the Handle away from you and towards the Hopper and Boot.
 - 3.1 Note: Position yourself so that the Handle is on your right. One full rotation produces one tablet.
4. Adjust the fill depth and punch pressure until the tablet is at the desired weight and thickness.



Settings and Adjustment

The TDP 0®'s settings can be adjusted. Tuning the Tooling can help with changing the tablets' characteristics and how they are ejected from the machine.

Ejection Height

When the Upper Punch is fully lifted, the Lower Punch in its highest position should be flush with the Die:

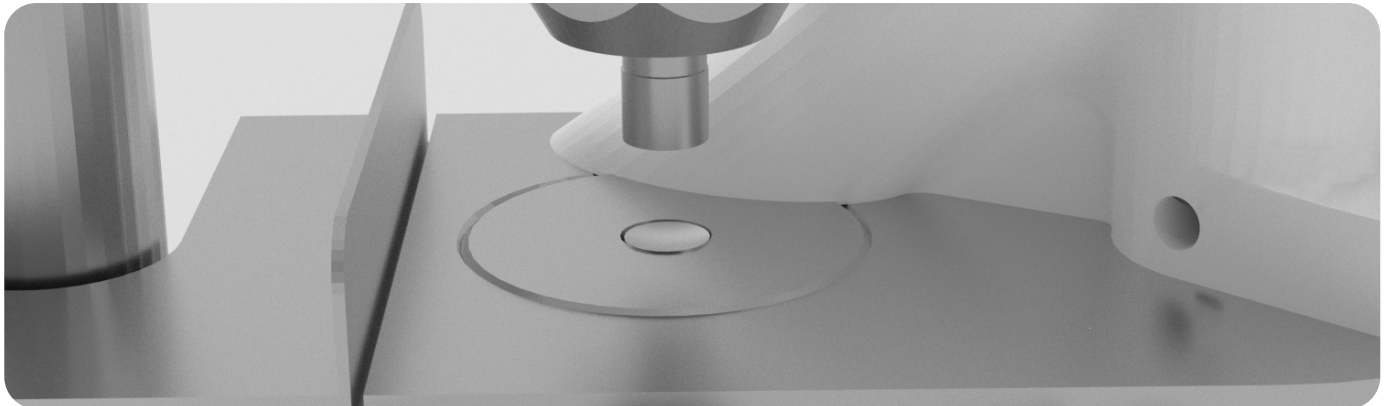

If the Lower Punch is above or below the Die's face, it will affect how smoothly the tablet is ejected. Adjusting the ejection height will help with this and can vary with different forms of Tooling.

Tools and Materials Needed

- Set of metric Allen keys with ball ends
- Disposable latex/rubber gloves (for food grade products and to protect hands from grease)
- Hairnet and/or beard net (food grade products only)
- Sterile shoe covers (food grade products only)

Instructions

Note: Wear latex/rubber gloves (and appropriate food grade attire if applicable) during this process.

1. Produce a test tablet to determine how the Tooling should be adjusted.
2. Remove the Ejection Tray with an Allen key.

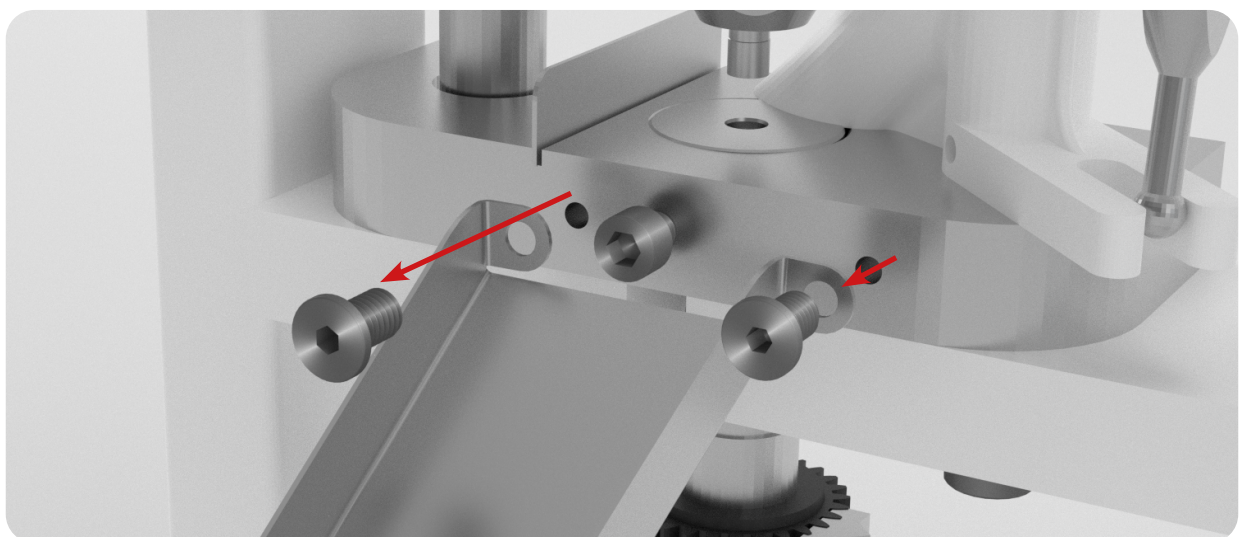

3. Remove the Lower Drift Pin Assembly Locking Bar bolt with an Allen key.

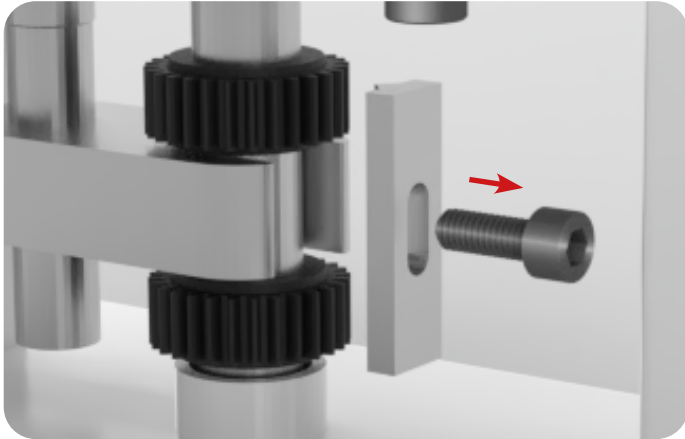

4. Rotate the Upper Cog in the Lower Drift Pin Assembly by hand.

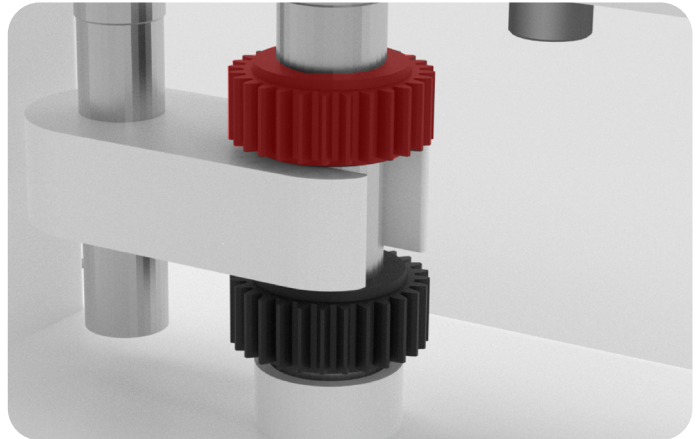

4.1 Note: To raise ejection height, turn clockwise. To lower ejection height, turn counterclockwise.

5. Secure the bolt in the Lower Drift Pin Assembly Locking Bar with an Allen key.

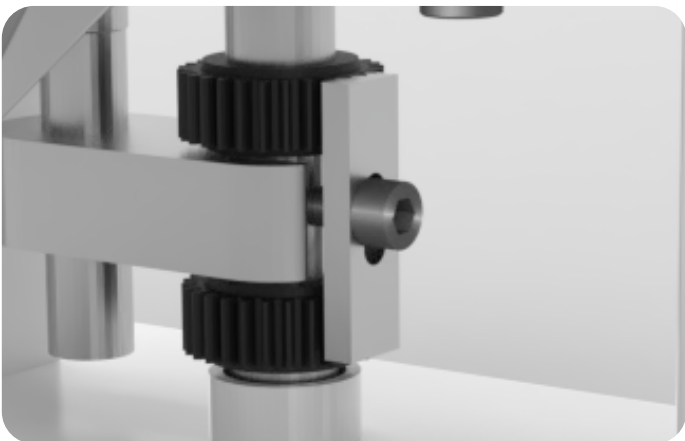

5.1 Note: Ensure that the Lower Drift Pin Assembly Locking Bar is situated vertically.

6. Reattach the Ejection Tray to the TDP 0.

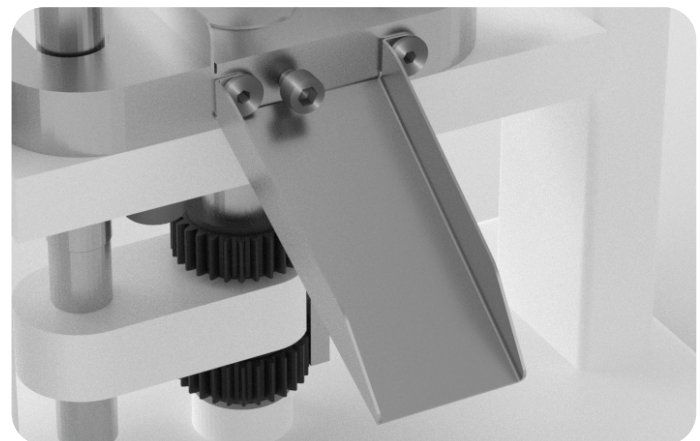

Fill Depth

At times, a tablet will be too light or too heavy, and its weight must change. Adjusting the fill depth determines the tablet's thickness and weight. This can be controlled by changing how high or low the Lower Punch sits.

Tools and Materials Needed

- Set of metric Allen keys with ball ends
- Disposable latex/rubber gloves (for food grade products and to protect hands from grease)
- Hairnet and/or beard net (food grade products only)
- Sterile shoe covers (food grade products only)

Instructions

Note: Wear latex/rubber gloves (and appropriate food grade attire if applicable) during this process.

1. Produce a test tablet to determine how the Tooling should be adjusted.
2. Rotate the machine until the Lower Drift Pin Assembly is at its highest position and the Boot is at the position to eject the tablet.
3. Remove the Ejection Tray with an Allen key.

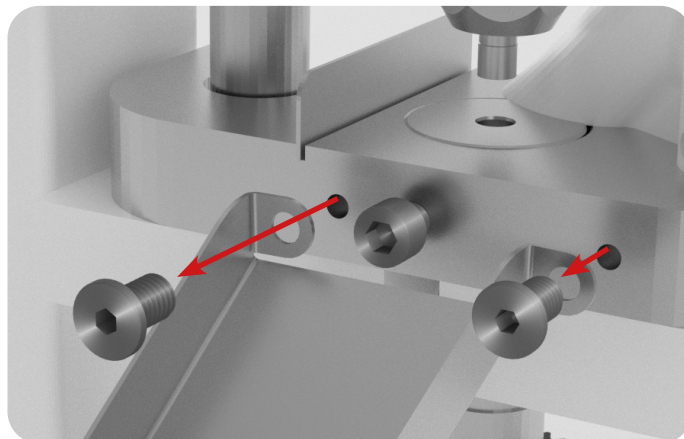

4. Remove the Lower Drift Pin Assembly Locking Bar with an Allen key.

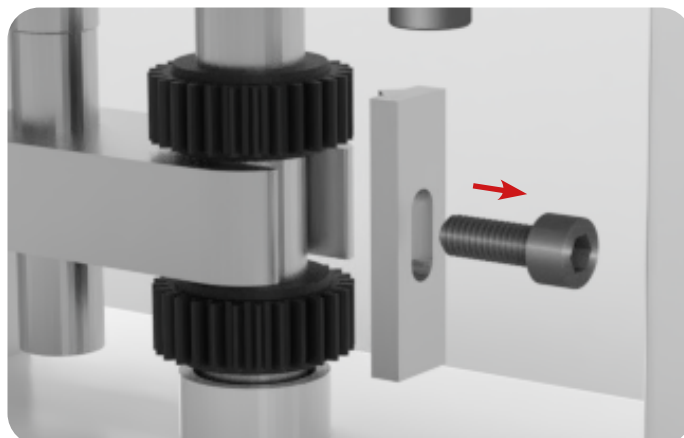

5. Rotate the Lower Cog in the Lower Drift Pin Assembly by hand.

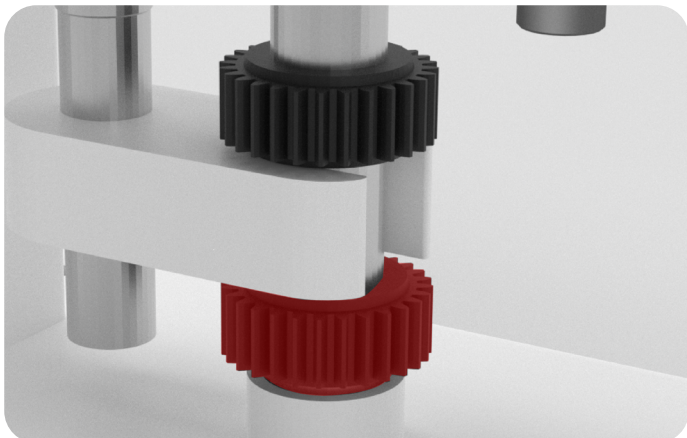

5.1 Note: To increase the tablet weight, turn counterclockwise. To decrease the tablet weight, turn clockwise.

6. Replace the bar in the Lower Drift Pin Assembly Locking Bar with an Allen key.

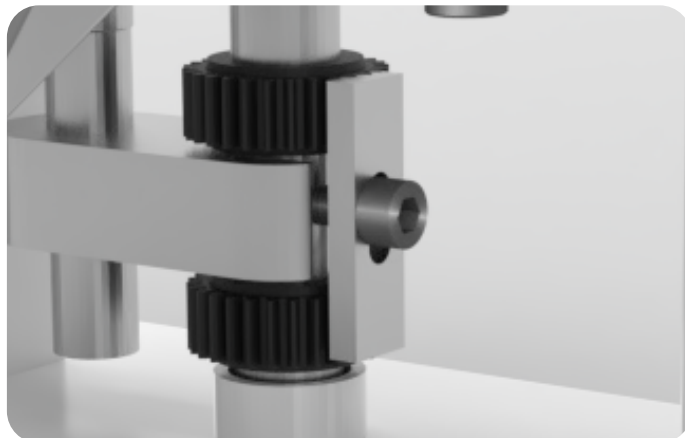

6.1 Note: Ensure that the Lower Drift Pin Assembly Locking Bar is situated vertically.

7. Reattach the Ejection Tray to the TDP 0.

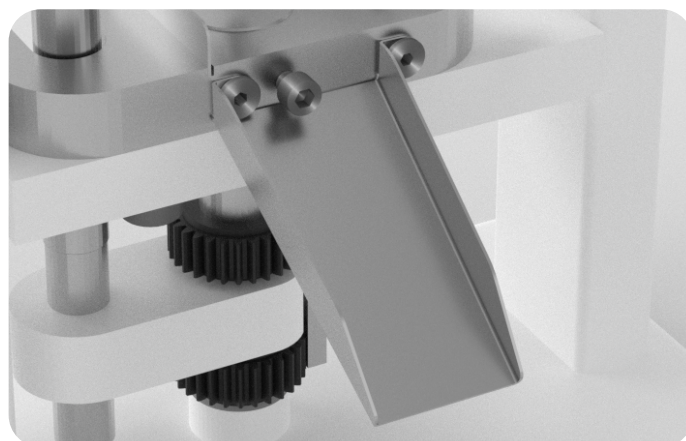

Punch Pressure

Sometimes tablets come out too soft and will crumble easily, which happens often after increasing the fill depth. Or, the machine can jam and will not be able to turn over. To correct this, the punch pressure needs to be adjusted in order to increase the tablet's firmness/de-jam the machine.

Tools and Materials Needed

- Set of metric Allen keys with ball ends
- 24 mm wrench
- Disposable latex/rubber gloves (for food grade products and to protect hands from grease)
- Hairnet and/or beard net (food grade products only)
- Sterile shoe covers (food grade products only)



CAUTION: Overtightening can damage the Tooling and/or Boot.

Instructions

Note: Wear latex/rubber gloves (and appropriate food grade attire if applicable) during this process.

1. Produce a test tablet to determine how the Tooling should be adjusted.
2. Remove the Ejection Tray with an Allen key.

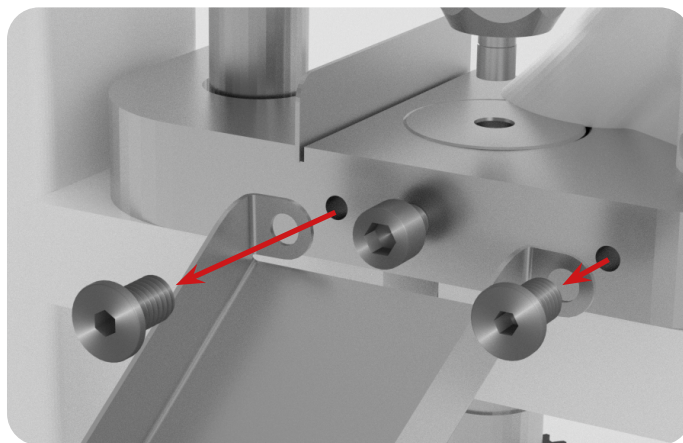

3. Remove any excess powder from the Base Plate.

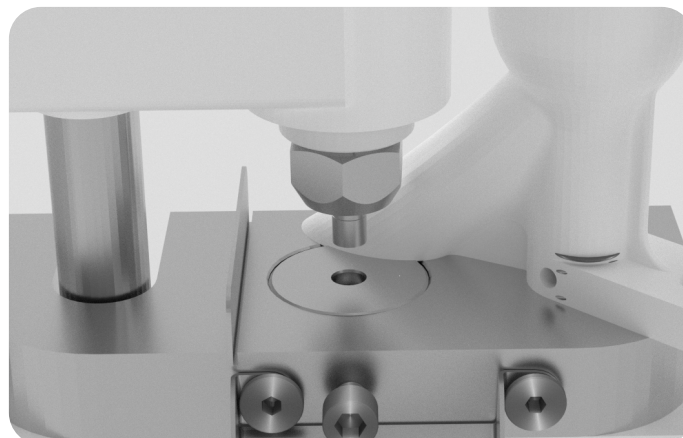

4. Turn the Handle until the Upper Punch is raised.



5. Loosen the Upper Drift Pin Assembly Locking Nut with a 24 mm wrench.

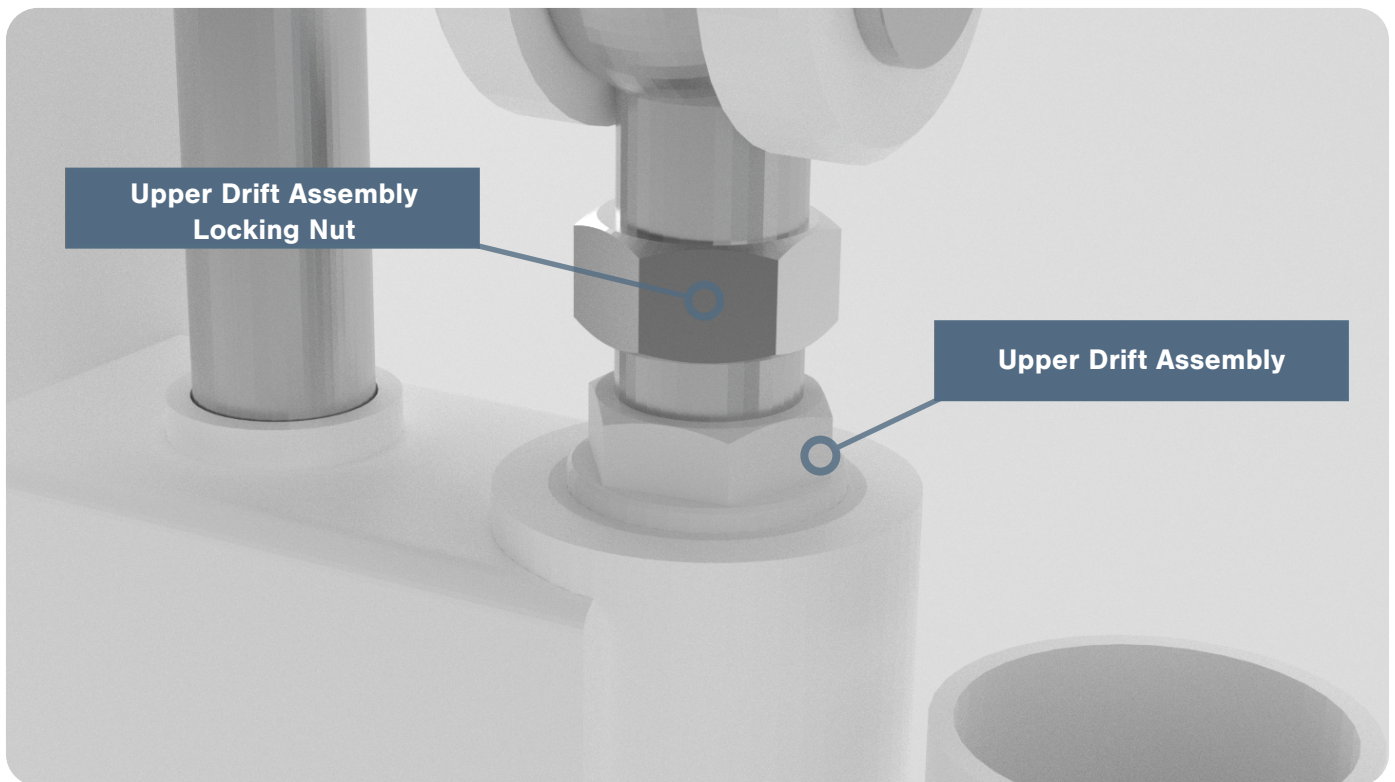

6. Turn the Handle until the Upper Drift Pin Assembly is exposed.
7. Rotate the Upper Drift Pin Assembly with a wrench or by hand.

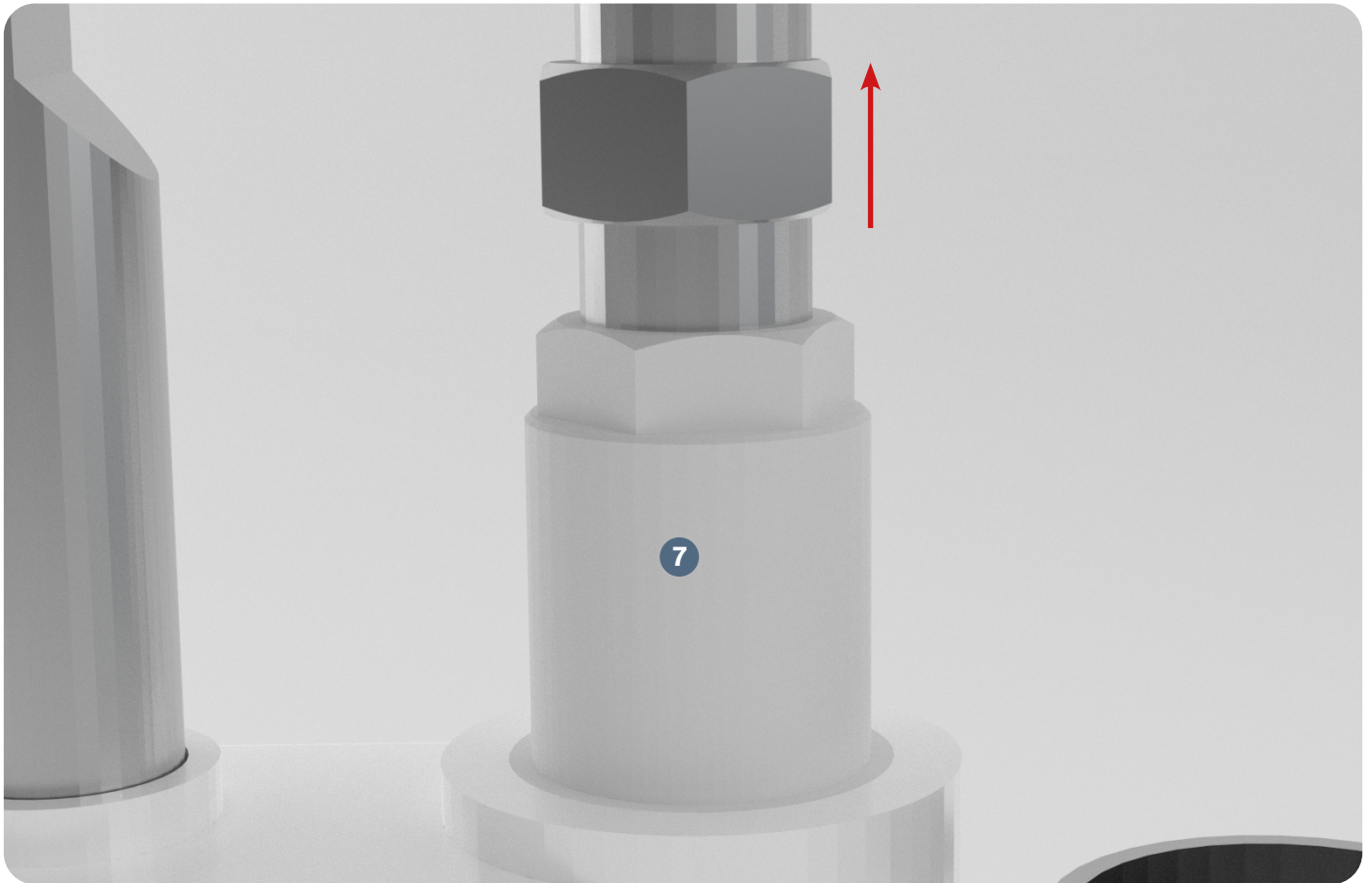

7.1 Note: To increase the pressure and harden the tablet, turn clockwise. To decrease the pressure and soften the tablet, turn counterclockwise.

8. Tighten the Upper Drift Pin Assembly Locking Nut with a 24 mm wrench.
9. Reattach the Ejection Tray with an Allen key.

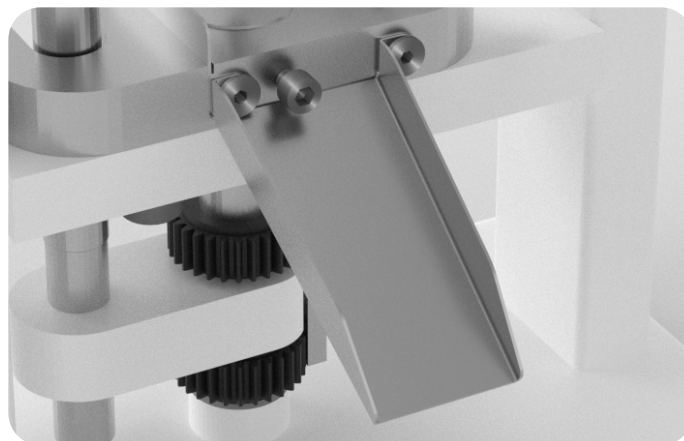

Maintenance

To ensure that the TDP 0[®] will have a long operational life, maintenance is essential. This section includes methods for replacing parts, troubleshooting solutions, and how often to grease and clean your machines to keep its performance optimal.

General Maintenance Prescriptions

- Use the maintenance checklist (found in the Appendix) before, during, and after machine operation.
- Make sure all grease points are maintained and regularly lubricated.
- Use an appropriate amount of lubricant. Excess grease can drip into the tablets as they are formed.
- Before reassembling the machine after cleaning, make sure that the parts are dried and oiled.
- Constantly check for any loose nuts and/or screws before, during, and after machine operation.
- If the machine is not used for more than a week, place the Tooling in an airtight container and cover in lubricant.

Lubrication

Regularly greasing your machine is vital to prolonging its operational life. Parts that are not greased properly can make the machine seize up and cause major problems later. LFA recommends maintaining a lubrication schedule for your TDP 0[®], which can be found in this section.

Tools and Materials Needed

- Grease gun
- Lubricant/grease (food grade if machine has contact with the food or drug product)
- Disposable latex/rubber gloves (for food grade products and to protect hands from grease)
- Hairnet and/or beard net (food grade products only)
- Sterile shoe covers (food grade products only)

Instructions

Note: Wear latex/rubber gloves (and appropriate food grade attire if applicable) during this process.

1. Rub a finger's worth of grease on the Boot Timing Cam's side.
 - 1.1 Note: Be sure to lubricate the Boot Timing Cam Runner.



2. Lubricate the Eccentric Sheave Strap's Grease Nipple with a grease gun.

2.1 Note: Rotate the Handle during this to ensure grease gets in between the Eccentric Sheave and the Eccentric Sheave Strap.

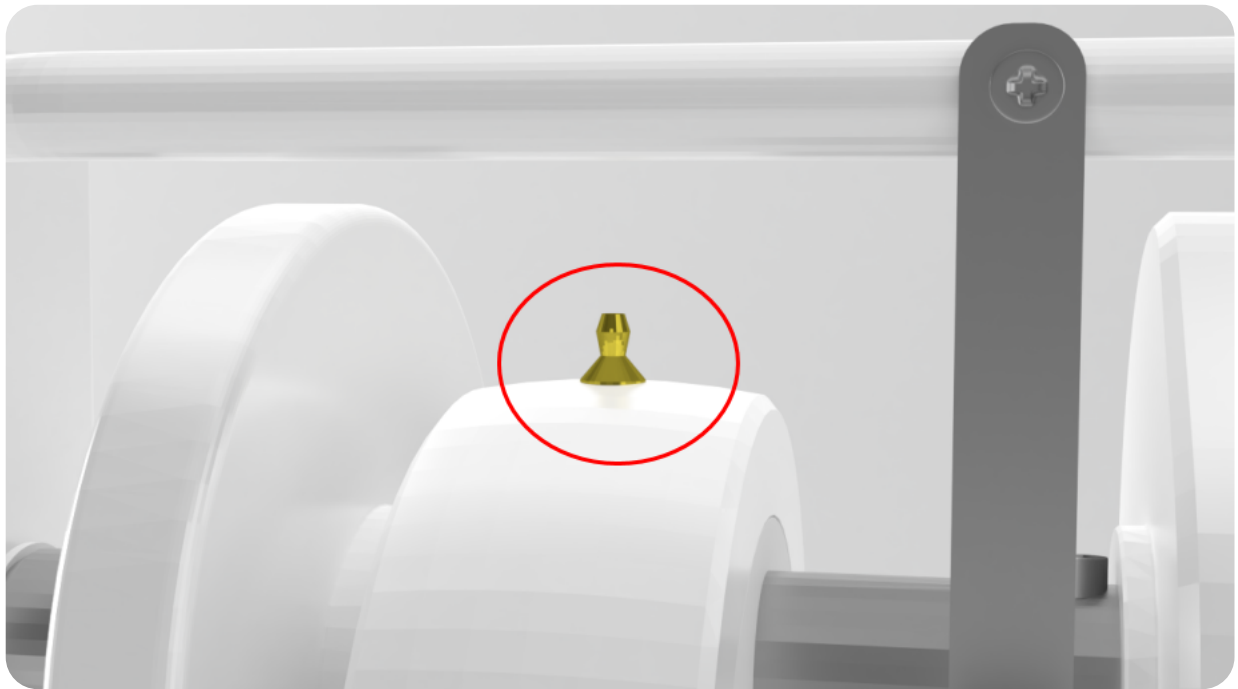

3. Rub a finger's worth of grease on the Lower Drift Pin Assembly Timing Cam.

3.1 Note: Be sure to lubricate the Lower Drift Pin Assembly Timing Rod's runner.

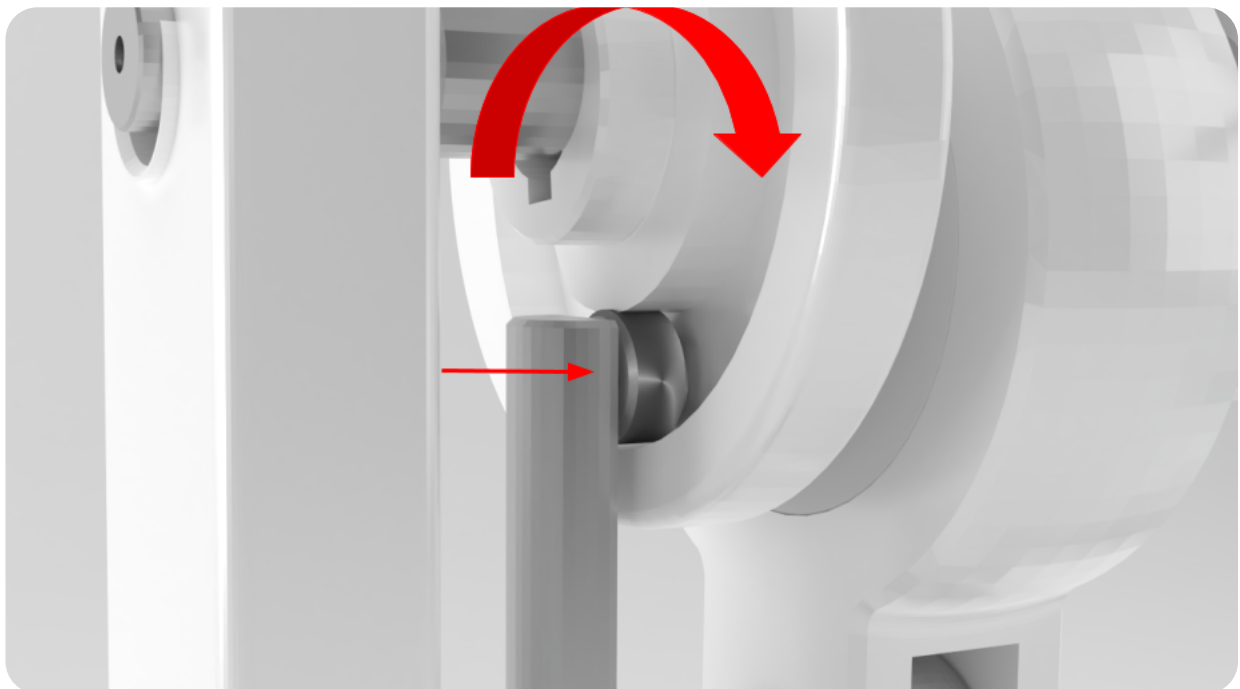

Lubrication Schedule

LFA recommends the following TDP 0[®] parts to be lubricated according to the following frequency:

Part	Location	Image	Frequency	Type of Lubricant
Tooling heads	The heads of the Upper Punch and Lower Punch		Visually inspect and apply when dry	Assembly paste
Tooling (after cleaning)	Storage container		Apply after cleaning	Mineral oil
Eccentric Sheave Strap	The topmost Grease Nipple		Apply (a) after every 5000 tablets, (b) after a deep clean, or (c) when the press has not been used for an extended period of time	NLGI Grade 2
Lower Drift Pin Assembly Timing Cam	Cam track and top of Lower Drift Pin Assembly Timing Rod		Apply (a) after every 5000 tablets, (b) after a deep clean, or (c) when the press has not been used for an extended period of time	NLGI Grade 2
Boot Timing Cam	Cam track and top of Boot Timing Bar		Apply (a) after every 5000 tablets, (b) after a deep clean, or (c) when the press has not been used for an extended period of time	NLGI Grade 2
Upper Drift Pin Assembly	The points at which the Upper Drift Pin Assembly and TDP Base meet		Apply a small amount whenever the press will be left unattended for an extended period of time	Mineral oil
Lower Drift Pin Assembly Timing Rod	The points at which the Lower Drift Pin Assembly Timing Rod and TDP Base meet		Apply a small amount whenever the press will be left unattended for an extended period of time	Mineral oil

Dismantling for Repair and Replacement

Eventually due to wear and tear, some parts of the TDP 0[®] will need to be removed for repair and replacement. To prevent any delays in your tablet production, it is best practice to keep extra parts just in case.

To buy a TDP 0[®] part replacement, simply go to <https://www.lfatabletpresses.com/products/pill-press-machine-spare-parts/tdp-0-parts>

Warranty

To access LFA's warranty policy, go to <https://www.lfatabletpresses.com/warranty>
If your part is eligible for warranty, have your part's serial number on hand and please contact LFA:

UK

Phone

+44 01869 250234

Email

support.uk@lfamachines.com

USA

Phone

+1 (682) 312-0309

Email

support.usa@lfamachines.com

Taiwan

Phone

+886 422031790

Email

support.asia@lfamachines.com

Wear Parts and Causes of Damage

Wear Part	Cause of Damage
Tooling	The Tooling can become chipped or broken. Lead times for a new set of Tooling can take as long as 6-8 weeks, so LFA recommends having a spare set or two.
Boot	The TDP 0 Boot is formed from a toughened plastic. This part can become trapped between the Die Bore and the Upper Punch, which usually results from user error.

Tooling

If you want to change the shape and diameter of the tablet, or if the Upper Punch, Lower Punch, and/or Die you currently have is damaged, it is necessary to change the Tooling.

To buy new Tooling from LFA, simply go to <https://www.lfatabletpresses.com/products/tablet-press-tooling>

Tools and Materials Needed

- Set of metric Allen keys with ball ends
- 24 mm wrenches (2)
- Tooling/die set (Upper Punch, Die, and Lower Punch)
- Grippers or pliers
- Hammer (if Die is difficult to remove)
- Disposable latex/rubber gloves (for food grade products and to protect hands from grease)
- Hairnet and/or beard net (food grade products only)
- Sterile shoe covers (food grade products only)



CAUTION: Overtightening bolts and/or screws can damage TDP 0 parts.

Instructions

Note: Wear latex/rubber gloves (and appropriate food grade attire if applicable) during this process.

Remove the Old Tooling

1. Remove the Hopper carefully and catch any powder still inside of it.



2. Remove the Ejection Tray with an Allen key.

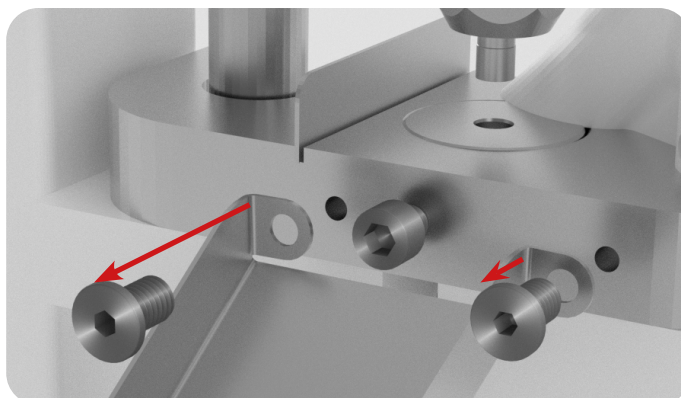

3. Loosen the Boot's set screw with an Allen key.

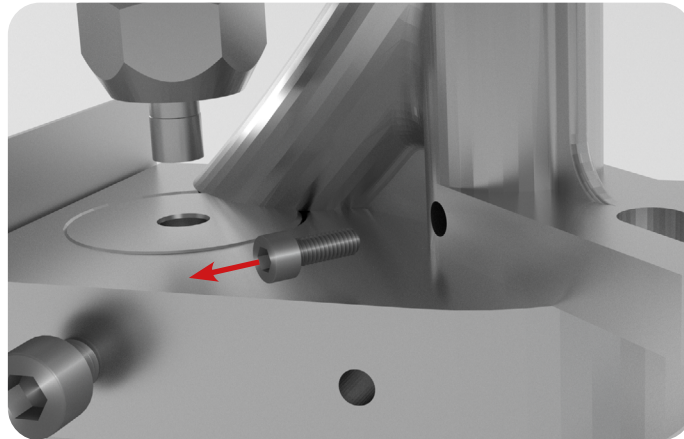

4. Remove the Boot Bolt and Spring underneath the Boot with an Allen key.

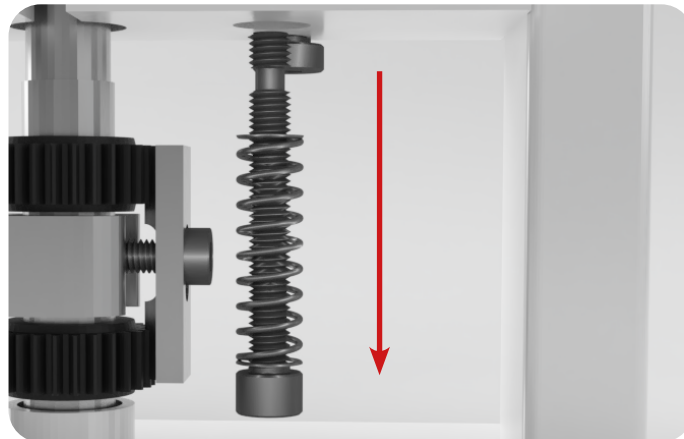

5. Take off the Boot carefully and remove any powder still inside it.

6. Loosen the bolts underneath the Base Plate with an Allen key.

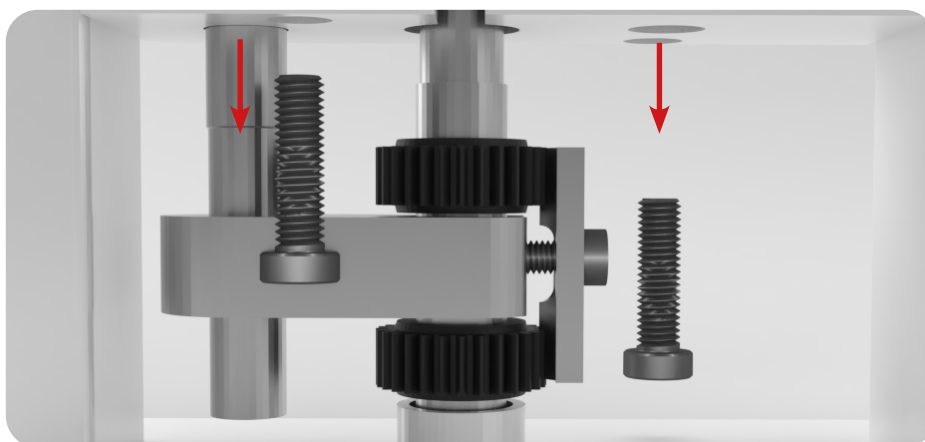

7. Turn the Handle until the Upper Drift Pin Assembly is lowered.
8. Loosen the Upper Punch Locking Nut with a wrench while keeping the Upper Punch Drift Assembly in place with another wrench.
9. Remove the Upper Punch by hand.

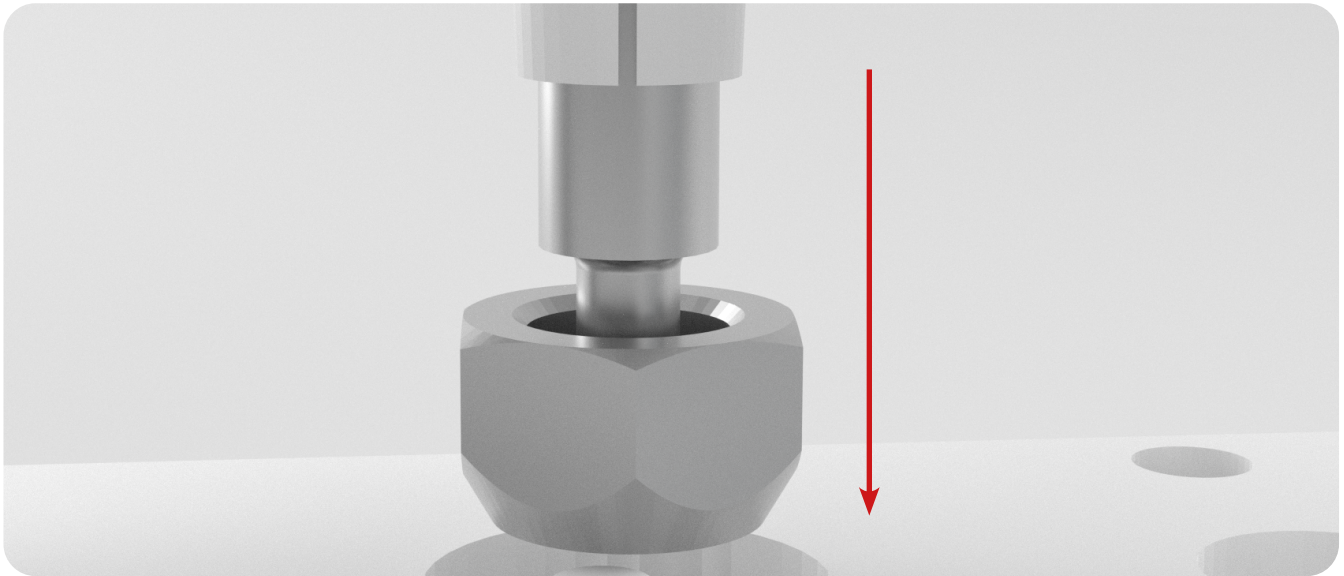

9.1 Note: If you cannot remove by hand, carefully use grippers or pliers.

10. Remove the Base Plate with the Die still inside it.
11. Remove the bolt that locks the Die with an Allen key.
12. Take out the Die from the middle of the Base Plate.
 - 12.1 Lightly tap the Die with a hammer if it is difficult to remove.

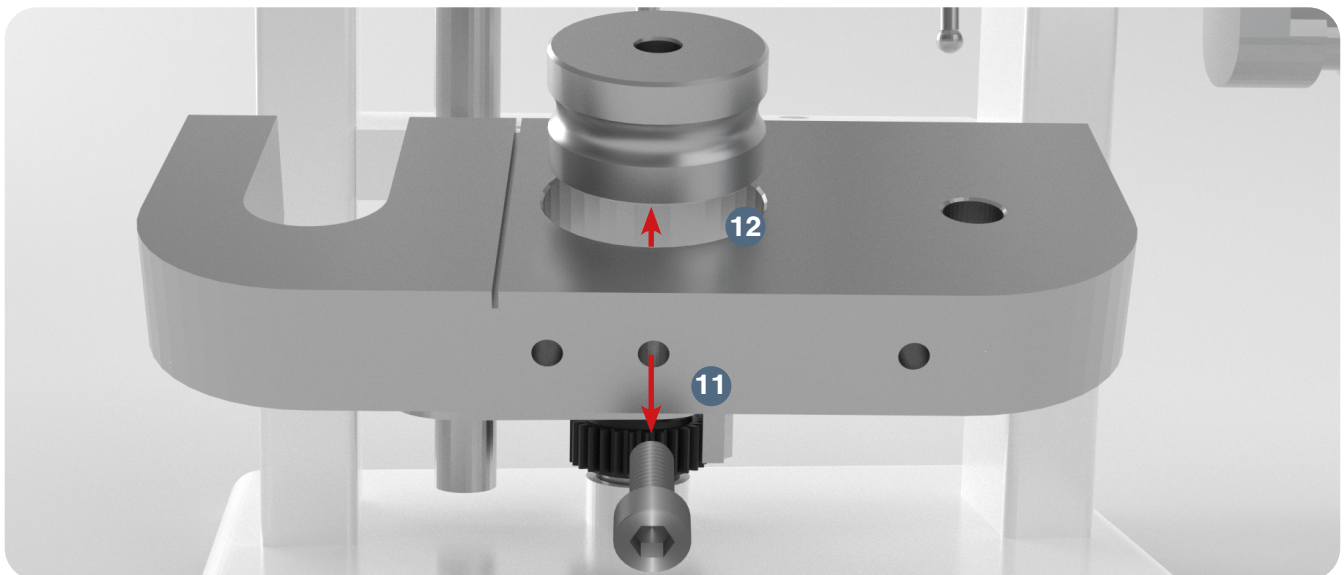

13. Remove the bolt that locks the Lower Punch with an Allen key.
14. Remove the Lower Punch by hand.

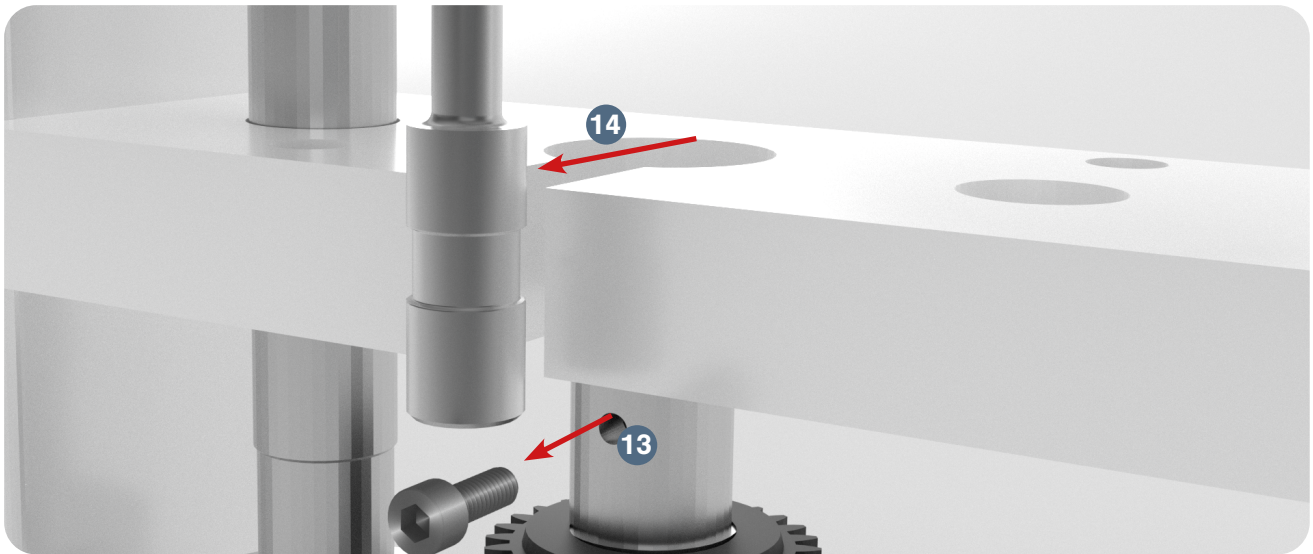

14.1 Note: If you cannot remove by hand, carefully use grippers or pliers.

Replace the Tooling

15. Insert the new Lower Punch into the Lower Drift Pin Assembly.
16. Reinsert the bolt that locks the Lower Punch with an Allen key.

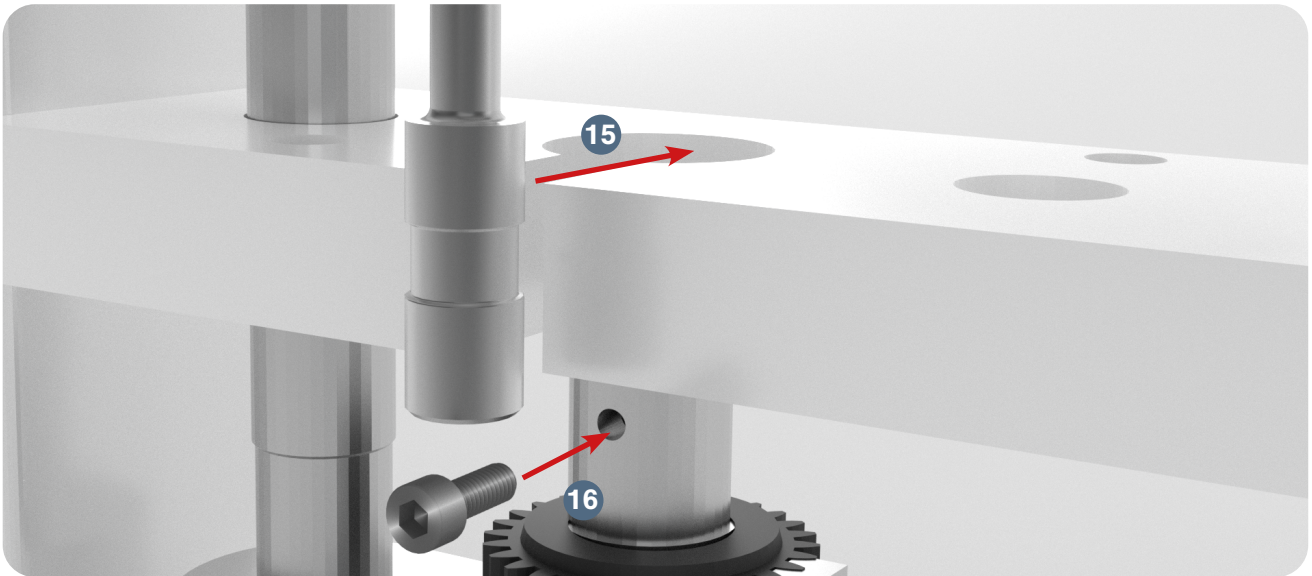

16.1 Note: Make sure that the Lower Punch's "keyed" section is facing forward.

Note: To help ensure that the Dies are inserted correctly, LFA recommends using an Insertion Ring. You can order the Die Seat Cleaner and Insertion Ring on our website at <https://www.lfatabletpresses.com/die-seat-cleaner-insertion-ring>



17. Place the Base Plate onto the TDP 0® Base.
18. Insert the new Die into the middle of the Base Plate.
19. Reinsert the bolt that locks the Die with an Allen key.

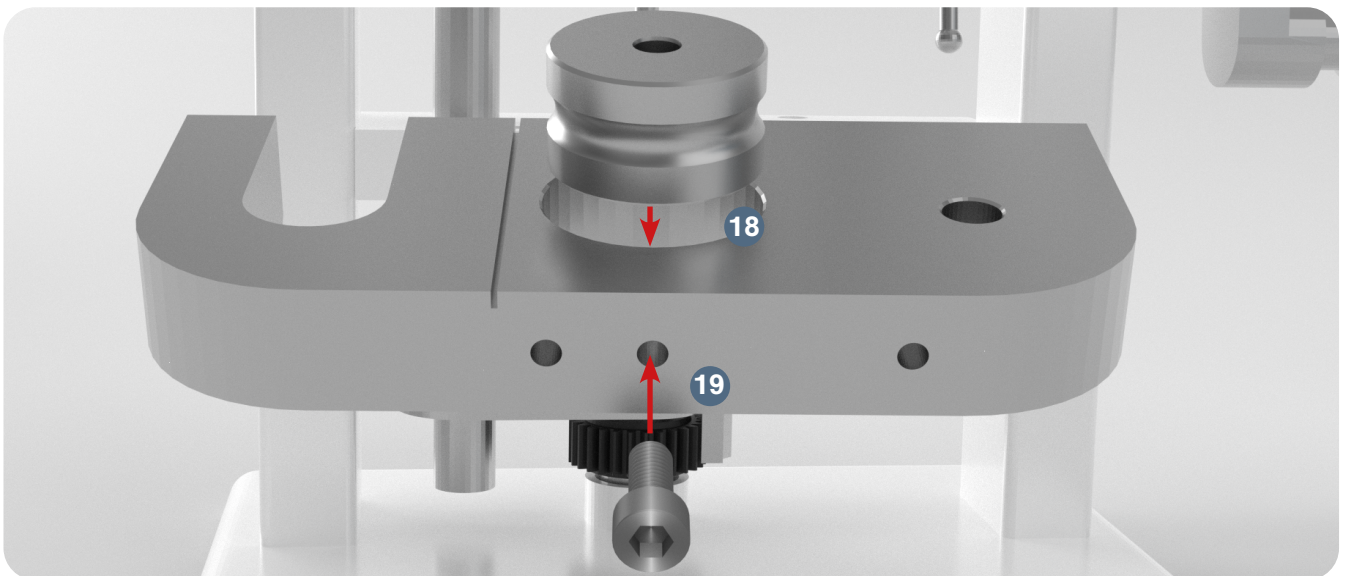

20. Insert the new Upper Punch into the Upper Drift Pin Assembly.

21. Tighten the Upper Punch Locking Nut onto the Upper Drift Pin Assembly with a wrench.

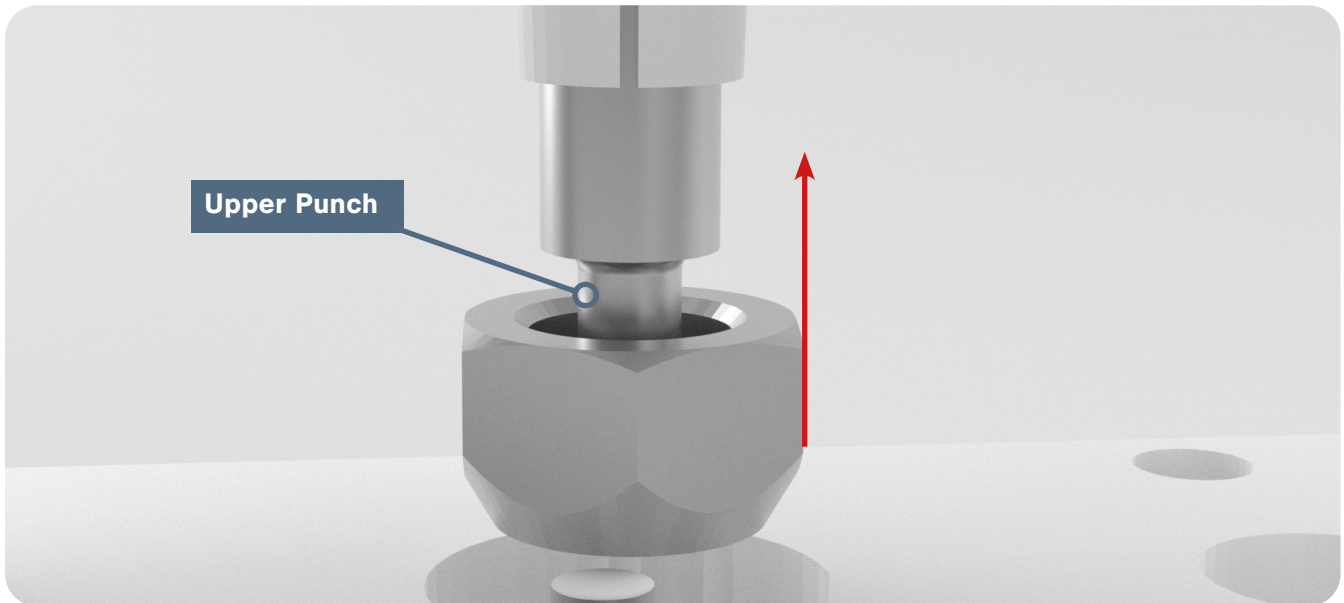

22. Rotate the Hand Wheel and carefully lower the Upper Punch into the Die.

22.1 Note: To watch a video on proper Base Plate alignment, go to <https://www.lfatabletpresses.com/videos/how-to-align-a-baseplate-on-a-tdp-5>

23. Tighten the Base Plate's bolts with an Allen key.

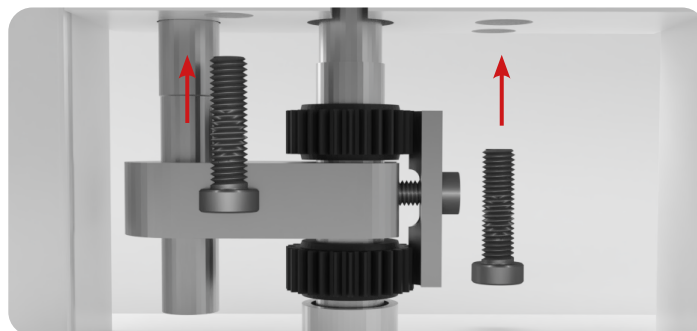

24. Position the Boot back on the Base Plate.

25. Insert the Boot Timing Bar's end in the Boot

26. Resecure the Boot Bolt and Spring underneath the Boot with an Allen key.

27. Tighten the Boot's set screw with an Allen key.

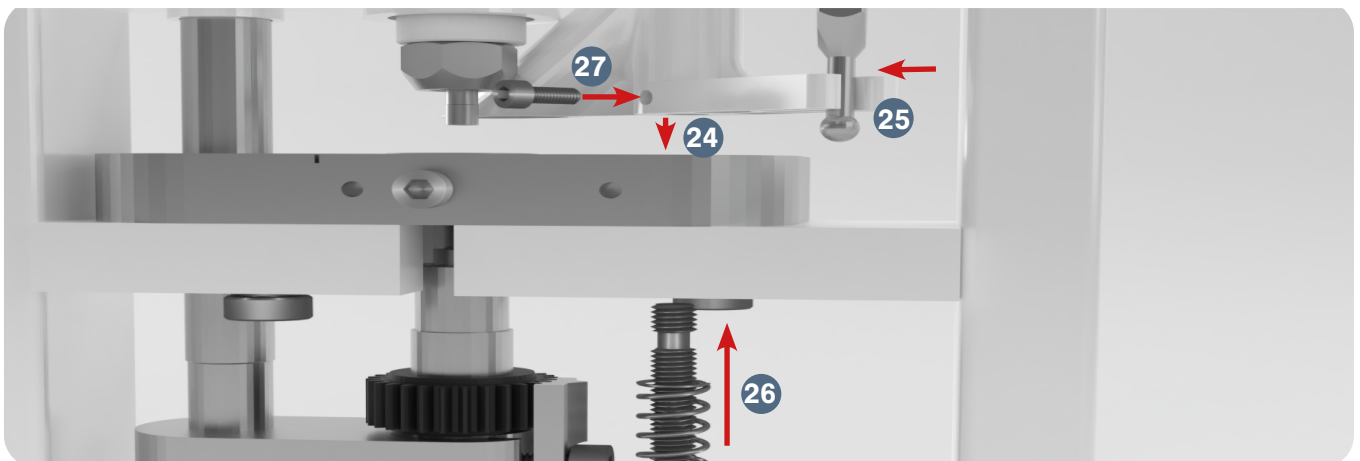

- 28. Reattach the Ejection Tray with an Allen key.
- 29. Reinsert the Hopper.

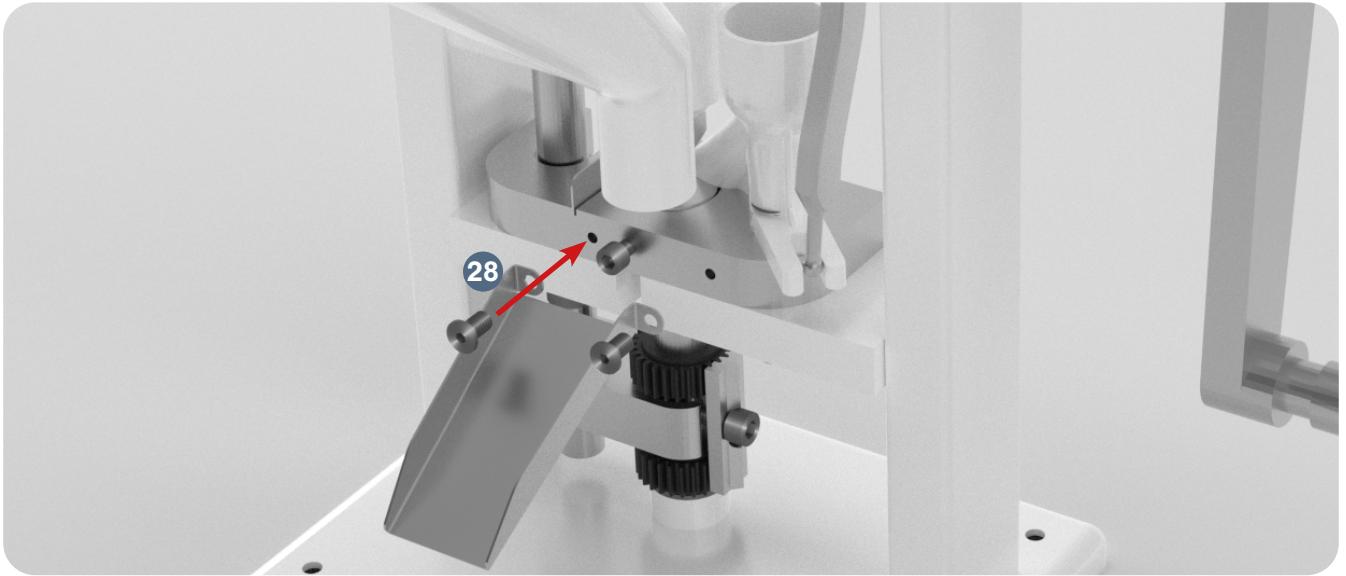

Boot Timing Bar

This part can become warped from collision, and it is critical to the TDP 0[®]'s operation. If you need to replace your TDP 0[®]'s Boot Timing Bar, the process is quite simple.

Tools and Materials Needed

- Set of metric Allen keys with ball ends
- 13 mm wrench
- New Boot Timing Bar part
- Disposable latex/rubber gloves (for food grade products and to protect hands from grease)
- Hairnet and/or beard net (food grade products only)
- Sterile shoe covers (food grade products only)



CAUTION: Overtightening bolts and/or screws can damage TDP 0[®] parts.

Instructions

Note: Wear latex/rubber gloves (and appropriate food grade attire if applicable) during this process.

Remove the Boot Timing Bar

1. Remove the Hopper carefully and catch any powder still inside of it.

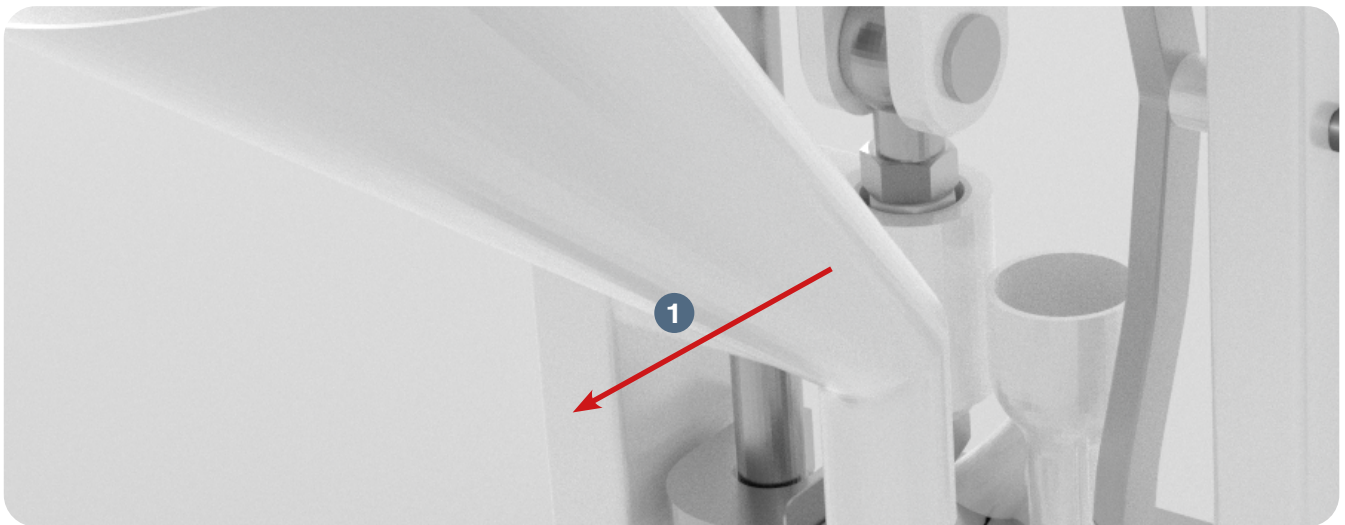

2. Loosen the Boot Timing Bar bolt's nuts with a wrench.
3. Loosen the Boot Timing Bar bolt with an Allen key.
4. Remove the Boot Timing Bar's end from the Boot.

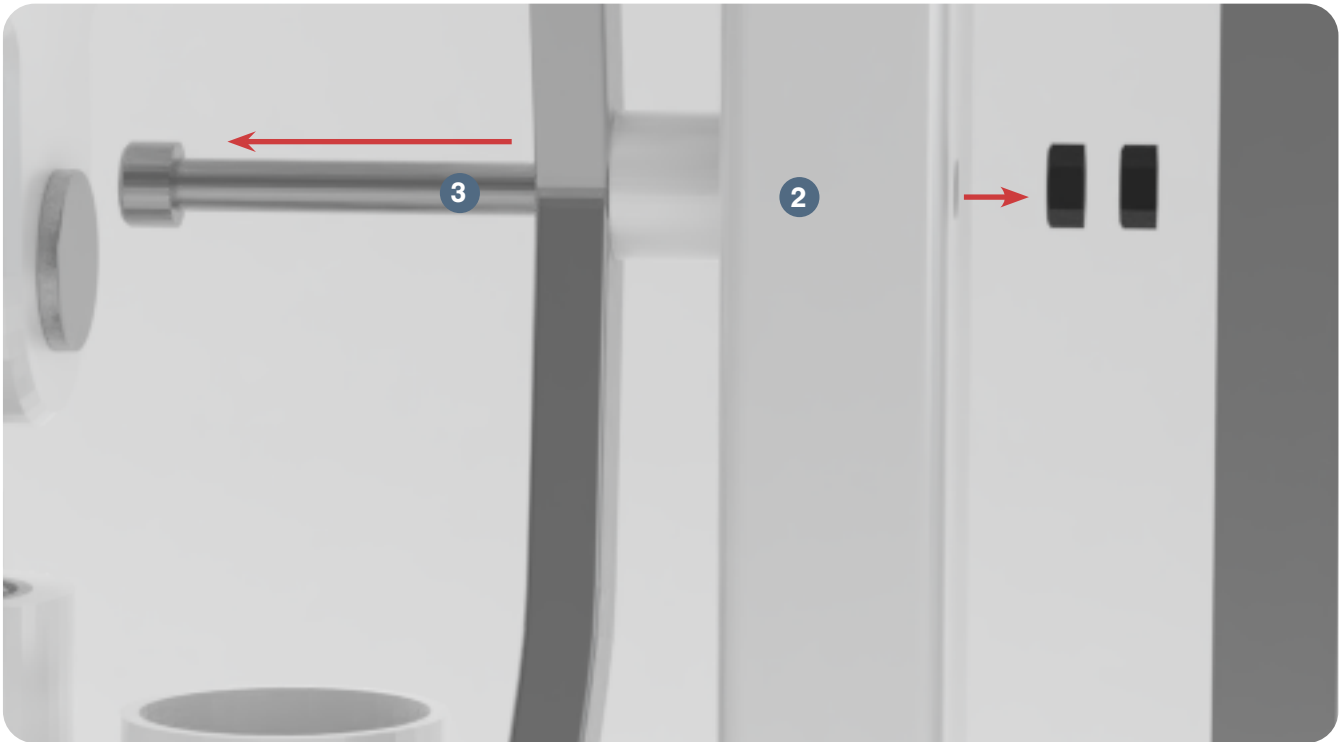

5. Remove the top part of Boot Timing Bar from the Boot Timing Cam.

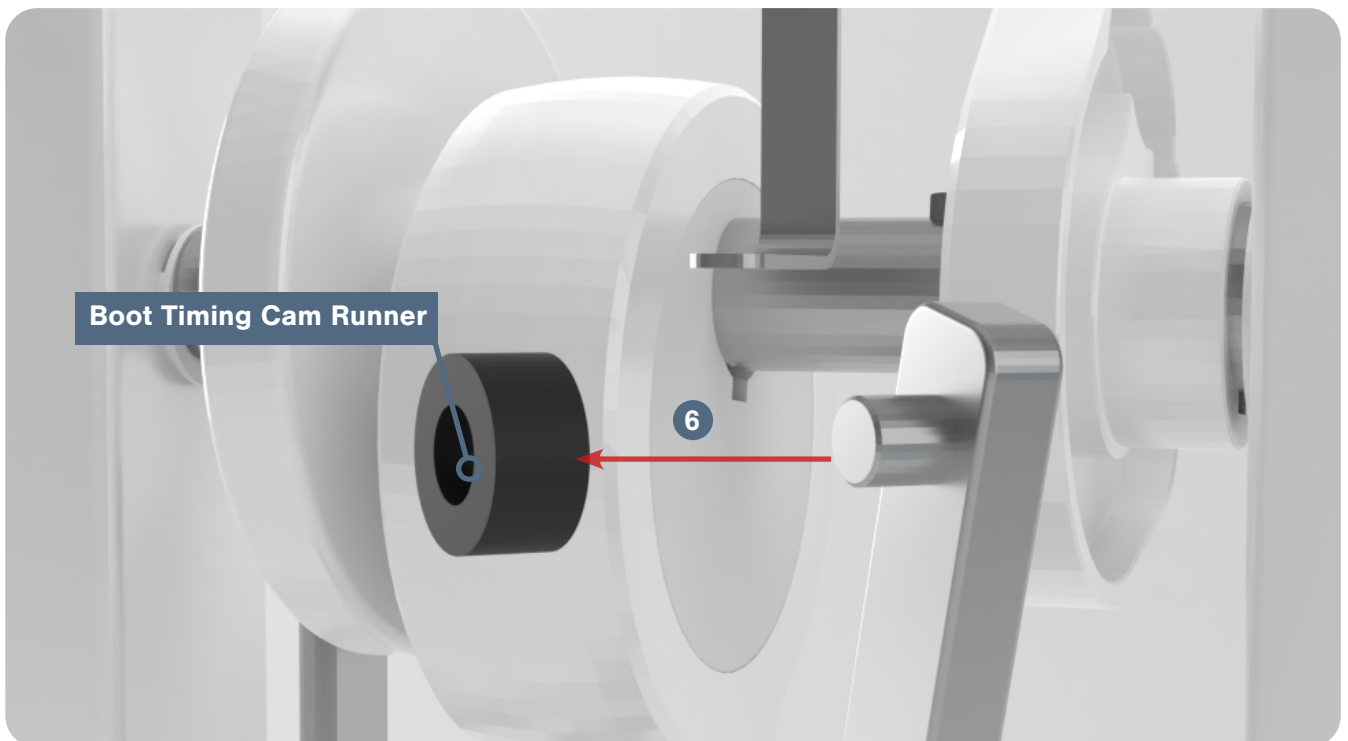

5.1 Note: To make removal easier, turn the Handle to rotate the Boot Timing Cam so you can easily access the Boot Timing Bar.

6. Remove the Boot Timing Cam Runner from the Boot Timing Bar by hand.
7. Remove the Boot Timing Bar from the Base Plate.

Replace the Boot Timing Bar

8. Place the Boot Timing Cam Runner on the new Boot Timing Bar.
9. Insert the new Boot Timing Bar with the runner into the side of the Boot Timing Cam.

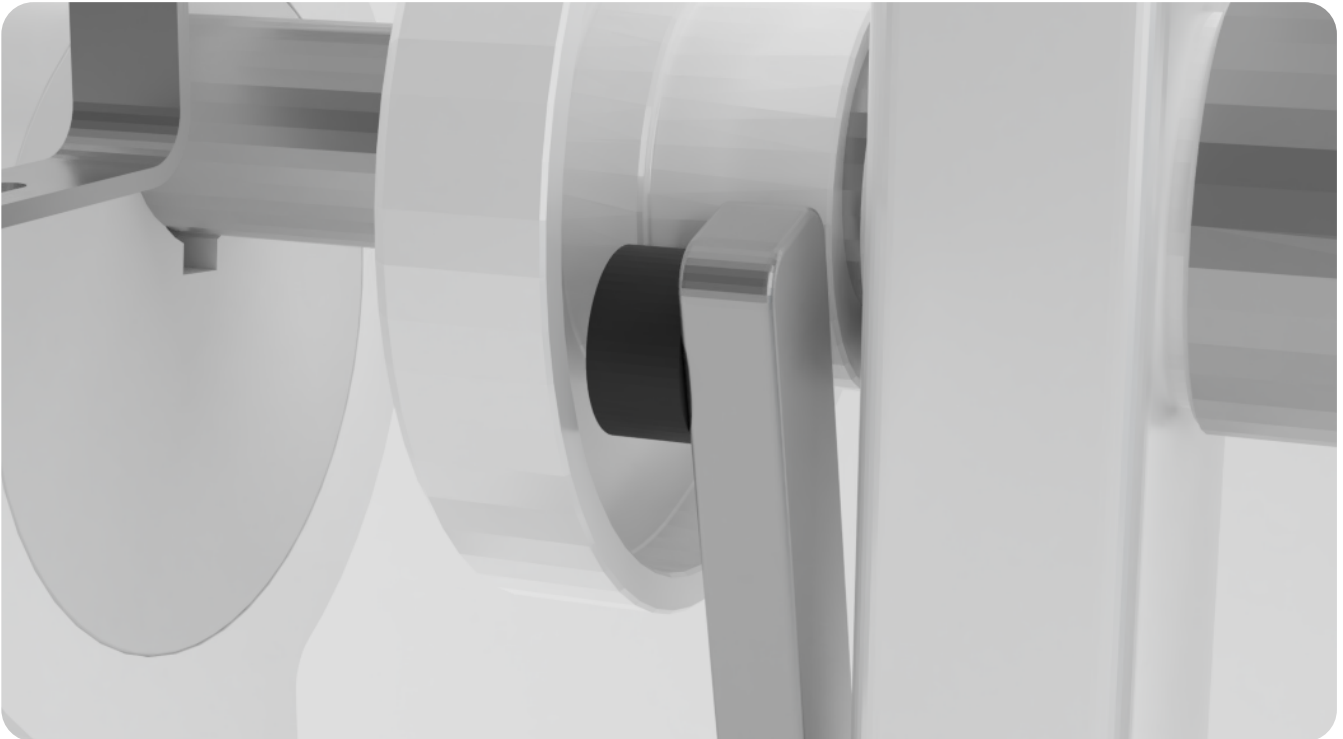

10. Insert the new Boot Timing Bar's end in the Boot
11. Tighten the Boot Timing Bar bolt with an Allen key.
12. Tighten the Boot Timing Bar bolt's nuts with a wrench.

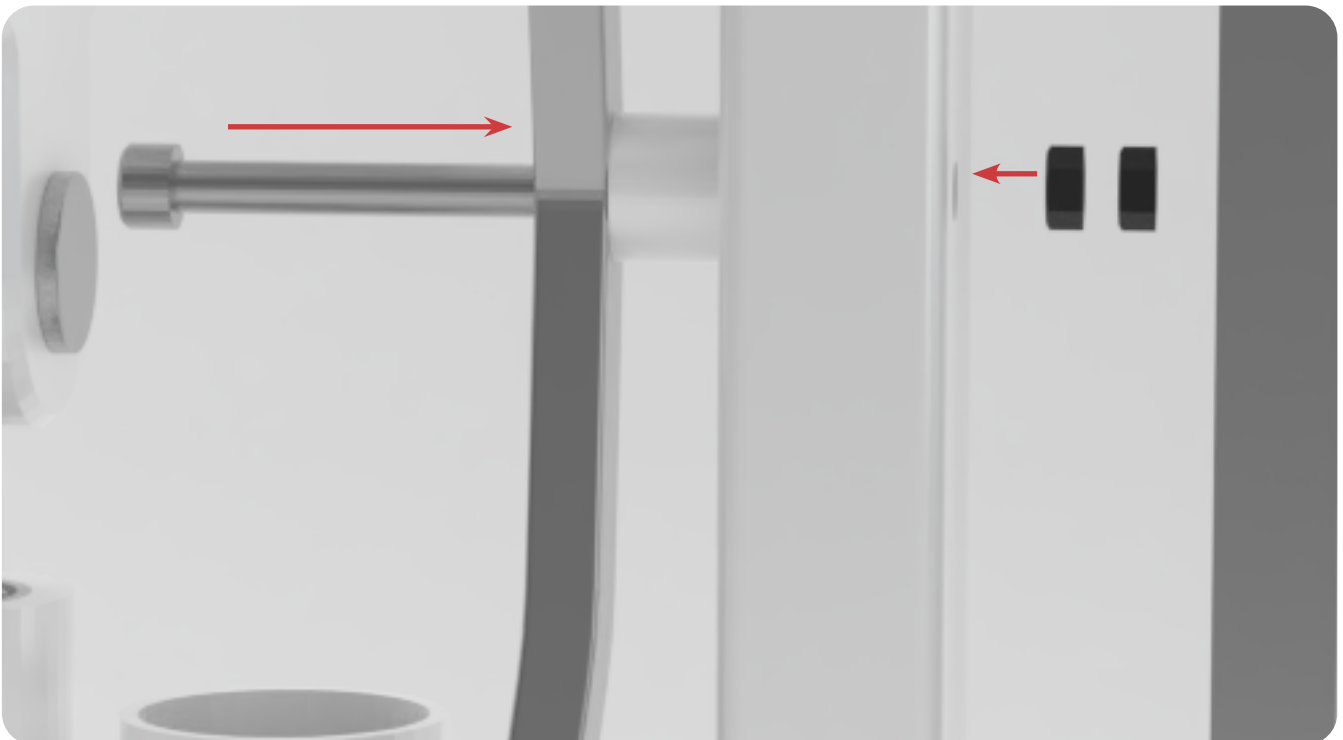

13. Reinsert the Hopper

Boot

Due to its constant movement, the Boot can wear down and prevent granular material from flowing smoothly. Replacing this part is a simple process.

Tools and Materials Needed

- Set of metric Allen keys with ball ends
- New Boot part
- Disposable latex/rubber gloves (for food grade products and to protect hands from grease)
- Hairnet and/or beard net (food grade products only)
- Sterile shoe covers (food grade products only)



CAUTION: Overtightening bolts and/or screws can damage TDP 0 parts.

Instructions

Note: Wear latex/rubber gloves (and appropriate food grade attire if applicable) during this process.

Remove the Boot

1. Remove the Hopper carefully and catch any powder still inside of it.



2. Remove the Ejection Tray with an Allen key.

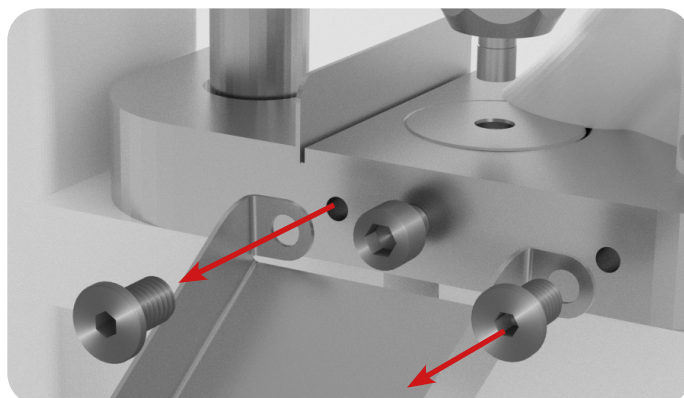

3. Loosen the Boot's set screw with an Allen key.

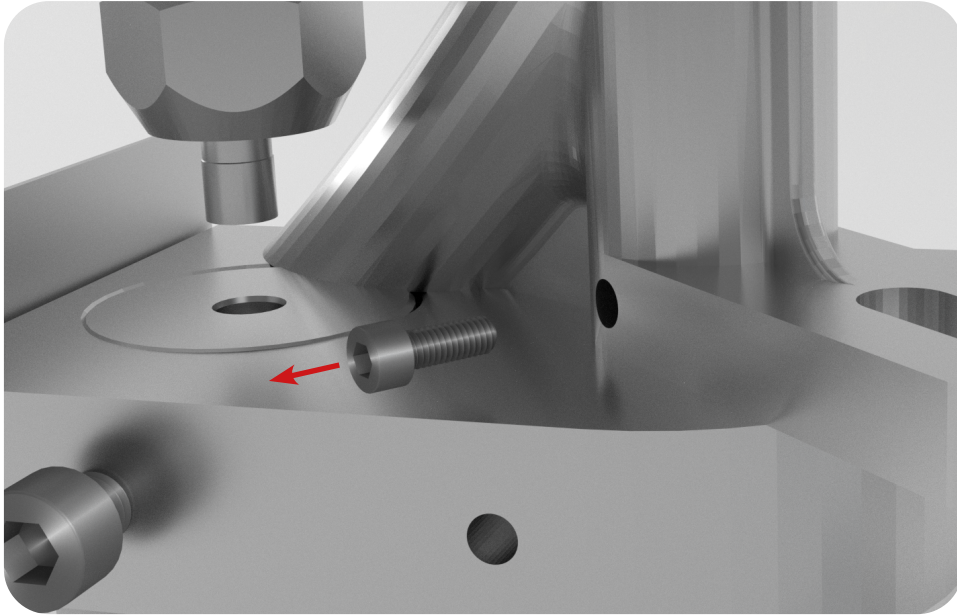

4. Remove the Boot Bolt and Spring underneath the Boot with an Allen key.

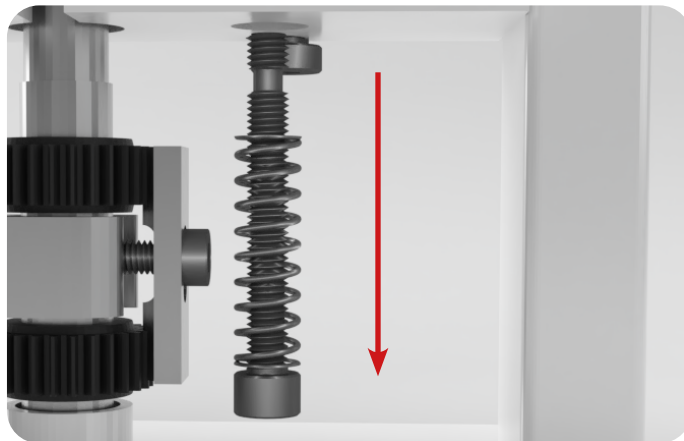

5. Take off the Boot carefully and remove any powder still inside it.

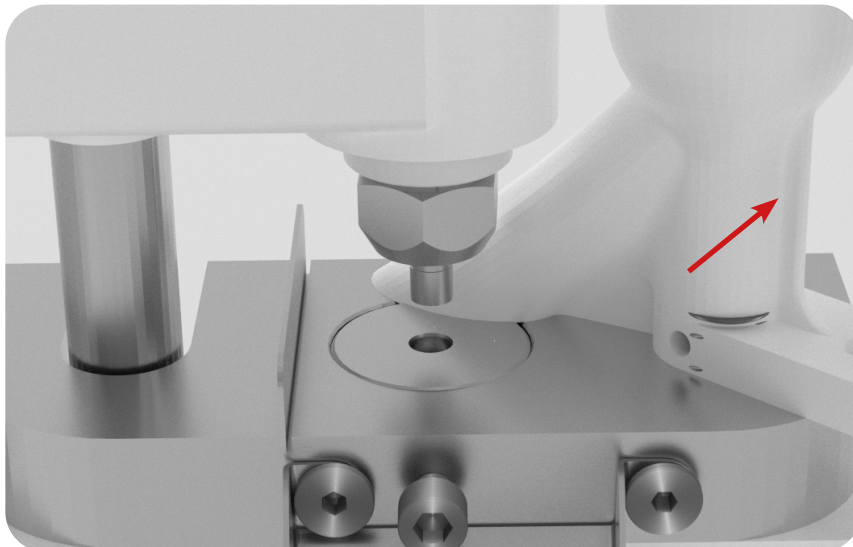

Replace the Boot

6. Position the new Boot on the Base Plate.
7. Insert the Boot Timing Bar's end in the new Boot
8. Resecure the Boot Bolt and Spring underneath the new Boot with an Allen key.
9. Tighten the new Boot's set screw with an Allen key.

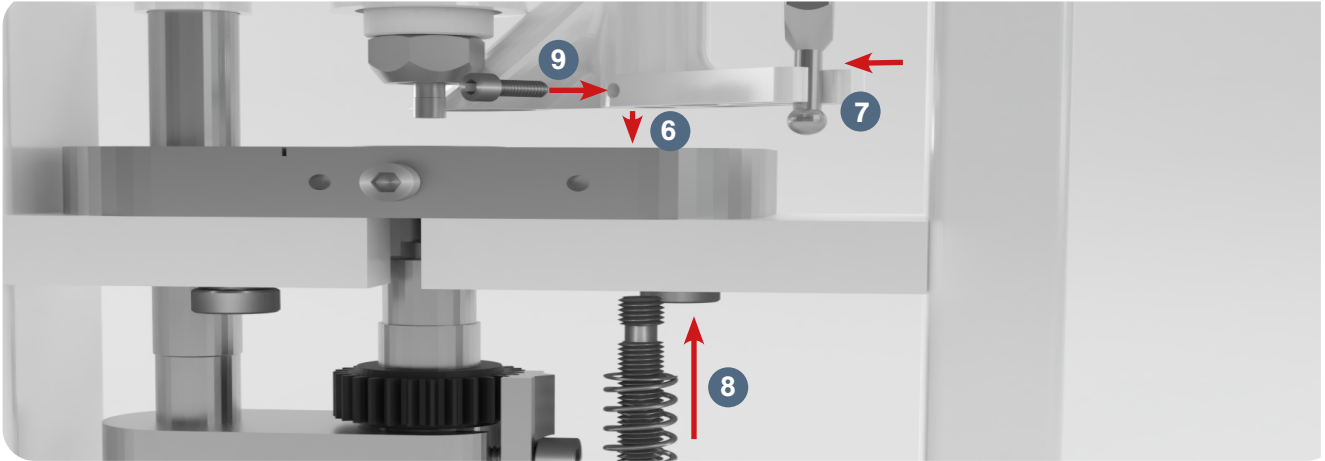

10. Reattach the Ejection Tray with an Allen key.
11. Reinsert the Hopper.

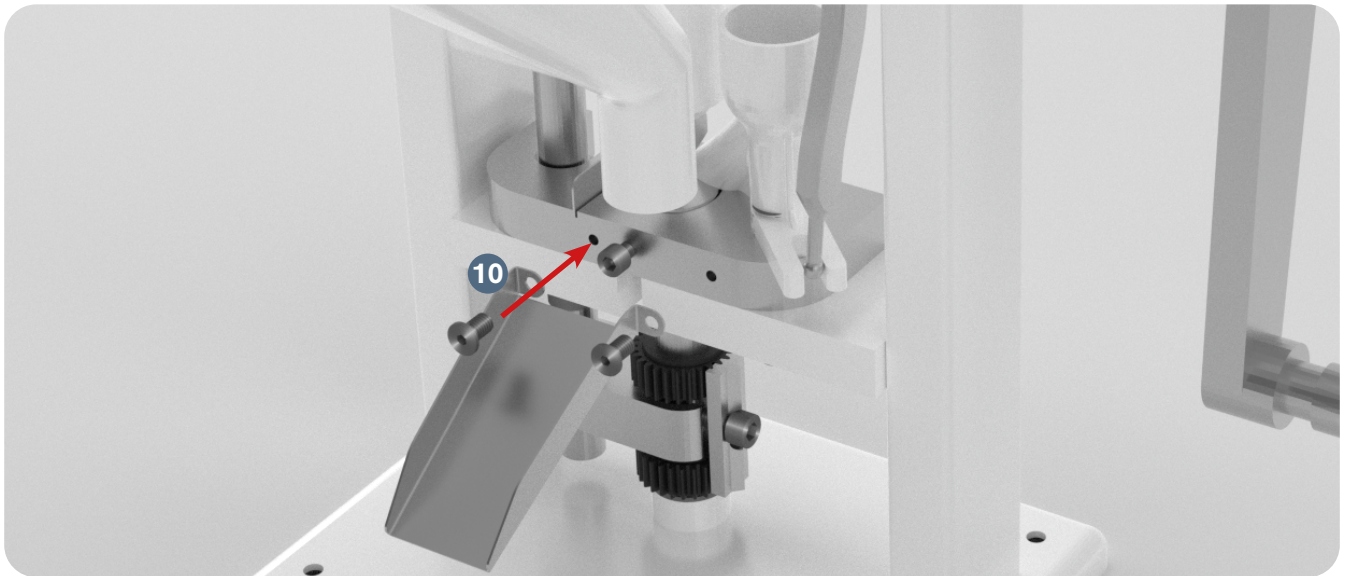

Upper Drift Pin Assembly

The Upper Drift Pin Assembly holds the TDP 0[®]s Upper Punch. Sometimes this part threads or bends, which interferes with smooth movement.

Tools and Materials Needed

- Set of metric Allen keys with ball ends
- 24 mm wrenches (2)
- New Upper Drift Pin Assembly part
- Disposable latex/rubber gloves (for food grade products and to protect hands from grease)
- Hairnet and/or beard net (food grade products only)
- Sterile shoe covers (food grade products only)



CAUTION: Overtightening bolts and/or screws can damage TDP 0[®] parts.

Instructions

Note: Wear latex/rubber gloves (and appropriate food grade attire if applicable) during this process.

Remove the Upper Drift Pin Assembly

1. Remove the Hopper carefully and catch any powder still inside of it.



2. Remove the Ejection Tray with an Allen key.

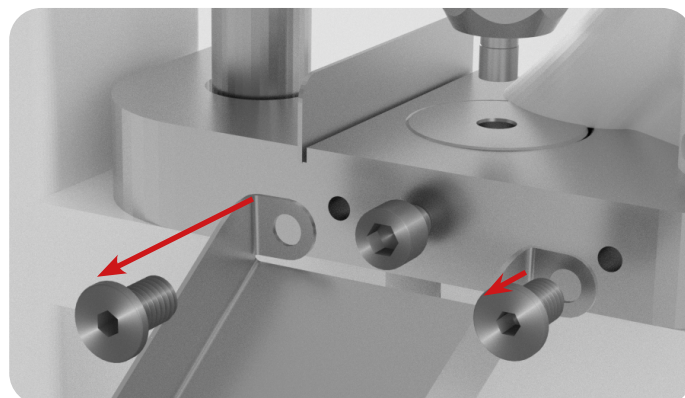

3. Loosen the Boot's set screw with an Allen key.

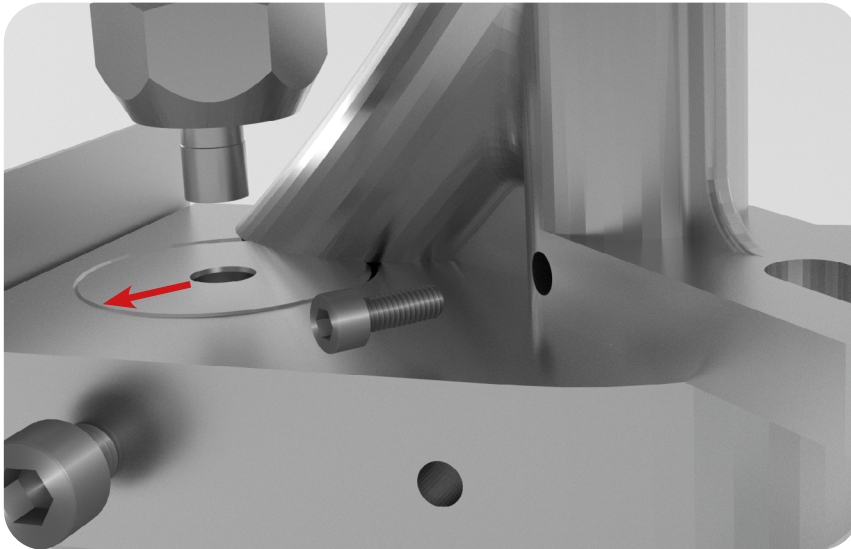

4. Remove the Boot Bolt and Spring underneath the Boot with an Allen key.

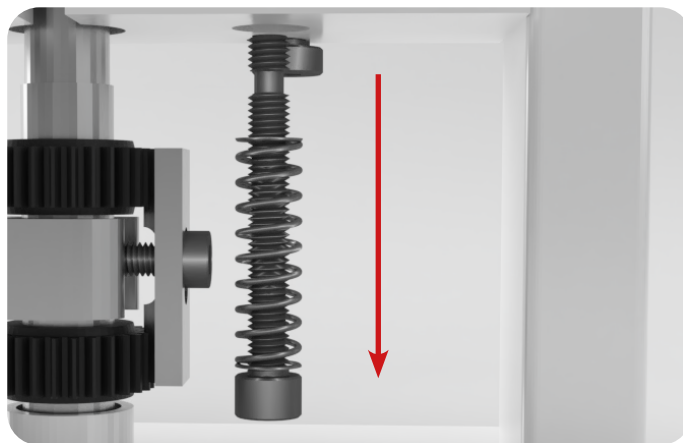

5. Take off the Boot carefully and remove any powder still inside it.

6. Loosen the bolts underneath the Base Plate with an Allen key.

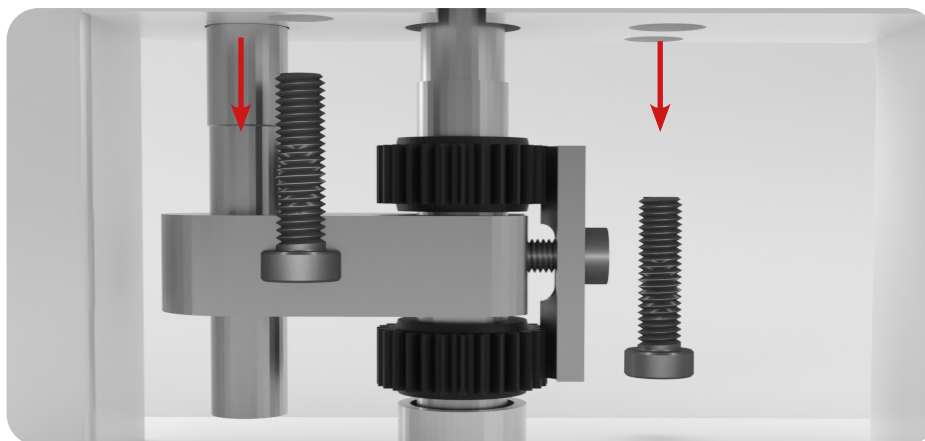

7. Turn the Handle until the Upper Drift Pin Assembly is lowered.
8. Loosen the Upper Punch Locking Nut with a wrench while keeping the Upper Punch Drift Assembly in place with another wrench.
9. Remove the Upper Punch by hand.

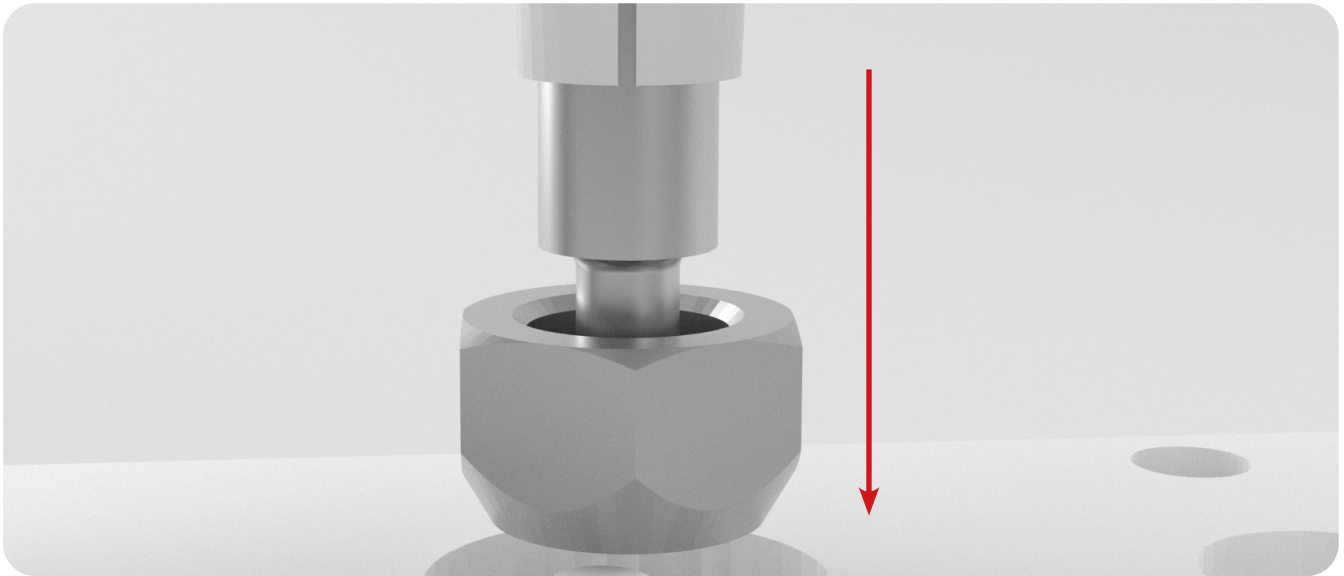

9.1 Note: If you cannot remove by hand, carefully use grippers or pliers.

10. Remove the Base Plate with the Die still inside it.
11. Remove the bolt that locks the Die with an Allen key.
12. Take out the Die from the middle of the Base Plate.
 - 12.1 Lightly tap the Die with a hammer if it is difficult to remove.

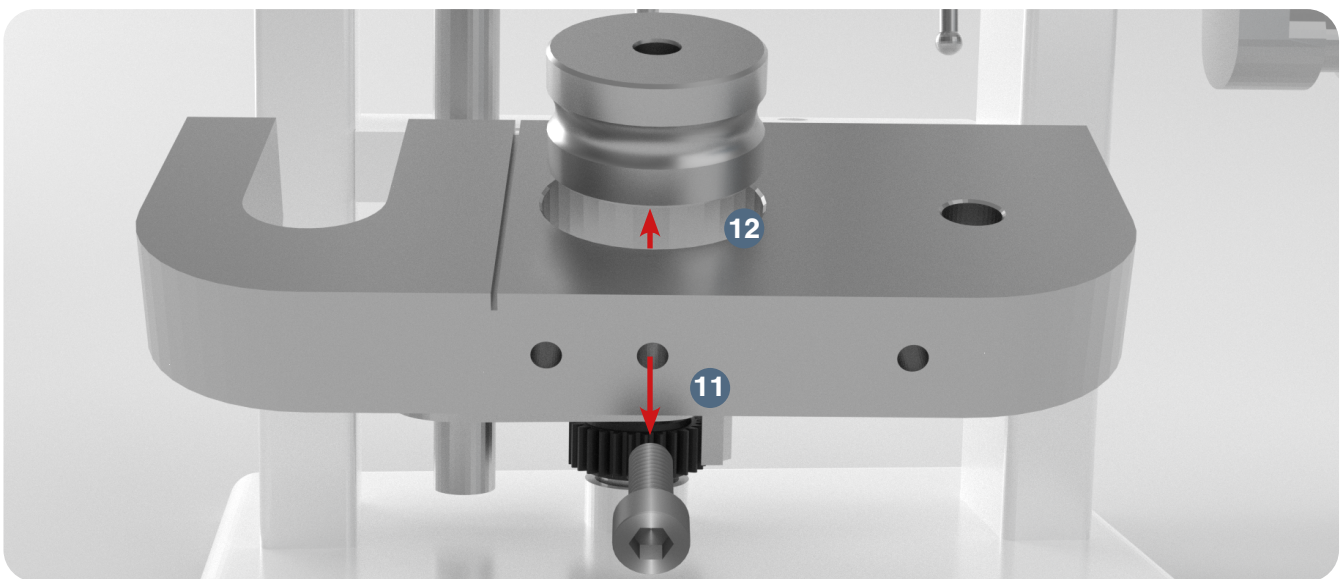

13. Remove the bolt that locks the Lower Punch with an Allen key.
14. Remove the Lower Punch by hand.

15. Loosen the Upper Drift Pin Assembly Locking Nut by hand.
15.1 Note: If you cannot loosen by hand, use a wrench.

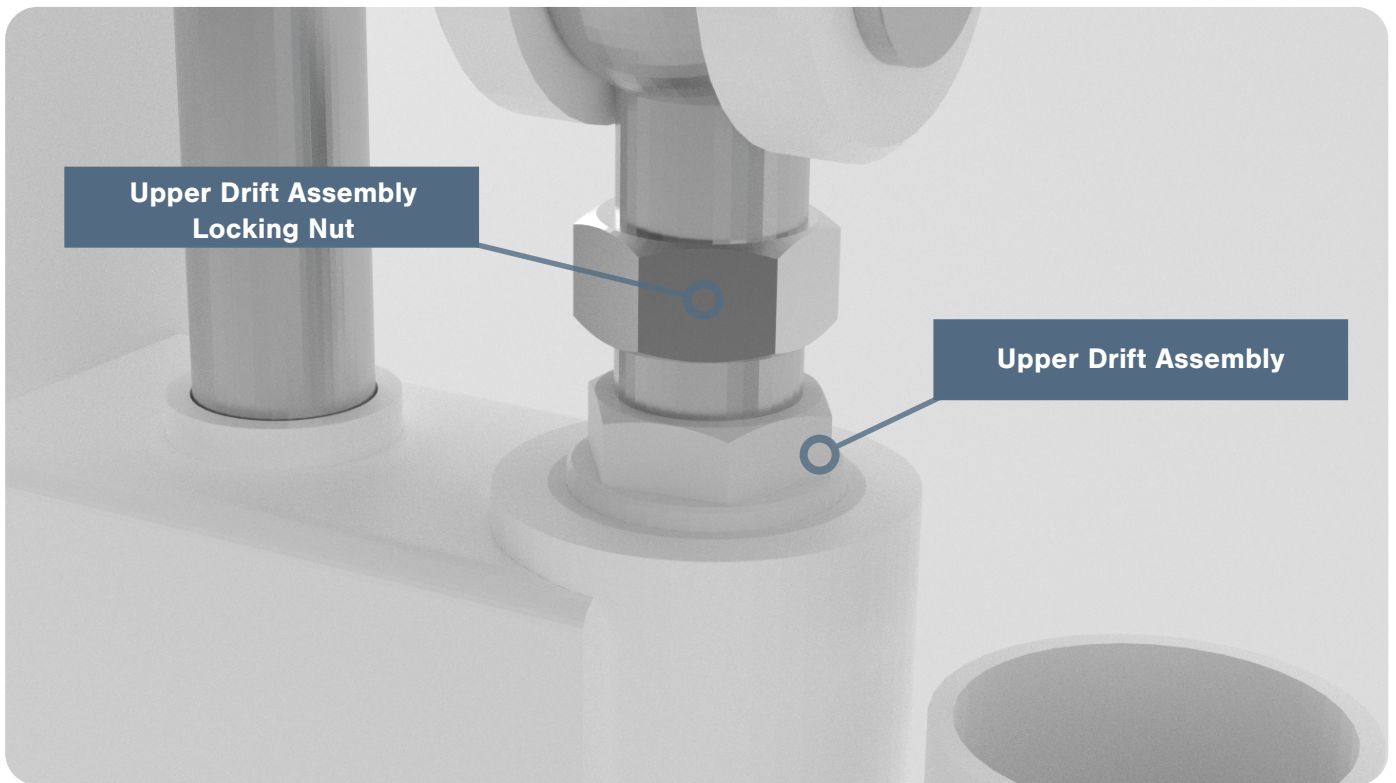

16. Unscrew the Upper Drift Pin Assembly from the Upper Drift Pin Assembly Rod Eye and Clevis.



Replace the Upper Drift Pin Assembly

17. Screw the new Upper Drift Pin Assembly onto the Upper Drift Pin Assembly Rod Eye and Clevis.



18. Tighten the Upper Drift Pin Assembly Locking Nut onto the Upper Drift Pin Assembly Rod Eye and Clevis by hand or with a wrench.

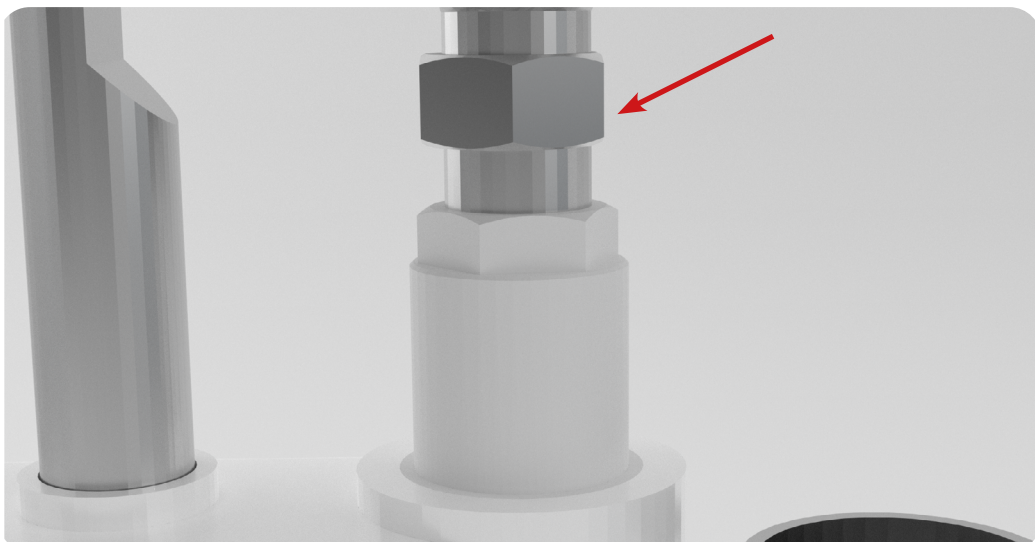

19. Reinsert the Lower Punch into the Lower Drift Pin Assembly.
20. Reinsert the bolt that locks the Lower Punch with an Allen key.

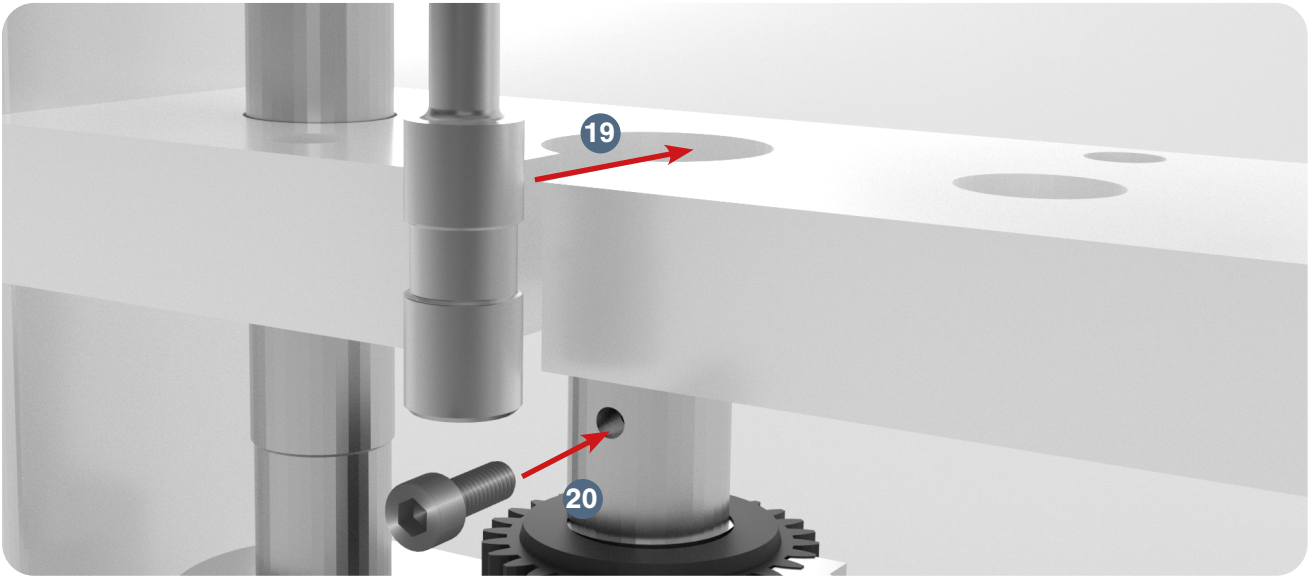

20.1 Note: Make sure that the Lower Punch's “keyed” section is facing forward.

21. Place the Base Plate onto the TDP 0 Base.
22. Insert the Die into the middle of the Base Plate.
23. Reinsert the bolt that locks the Die with an Allen key.

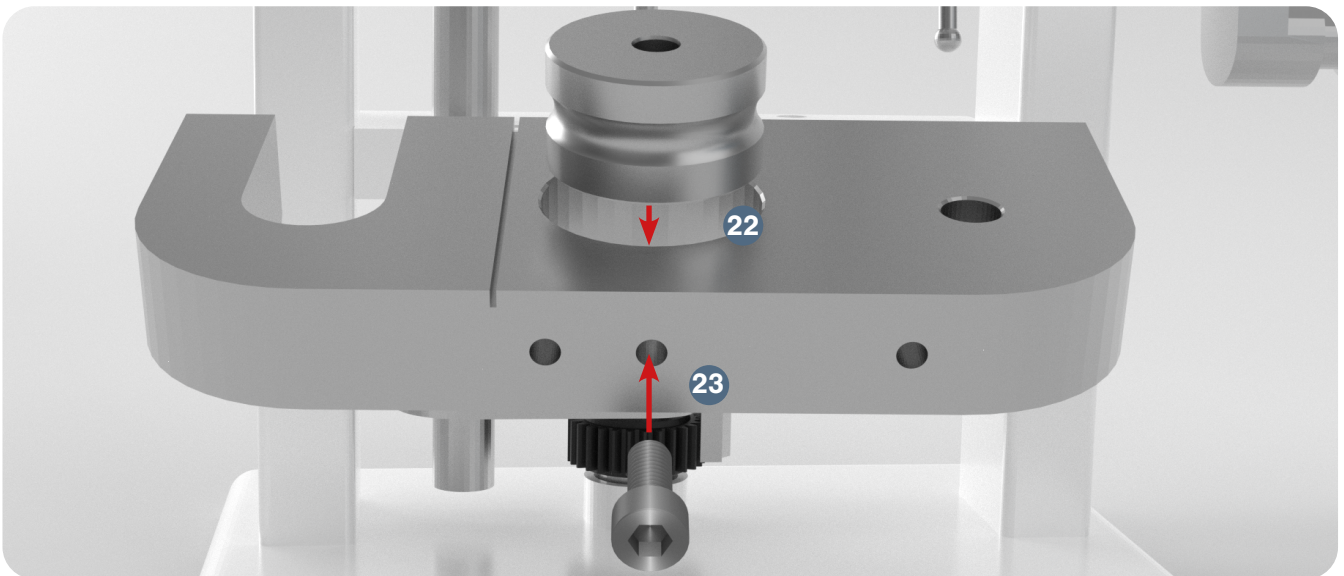

- 24. Insert the Upper Punch into the Upper Drift Pin Assembly.
- 25. Tighten the Upper Punch Locking Nut onto the Upper Drift Pin Assembly with a wrench.

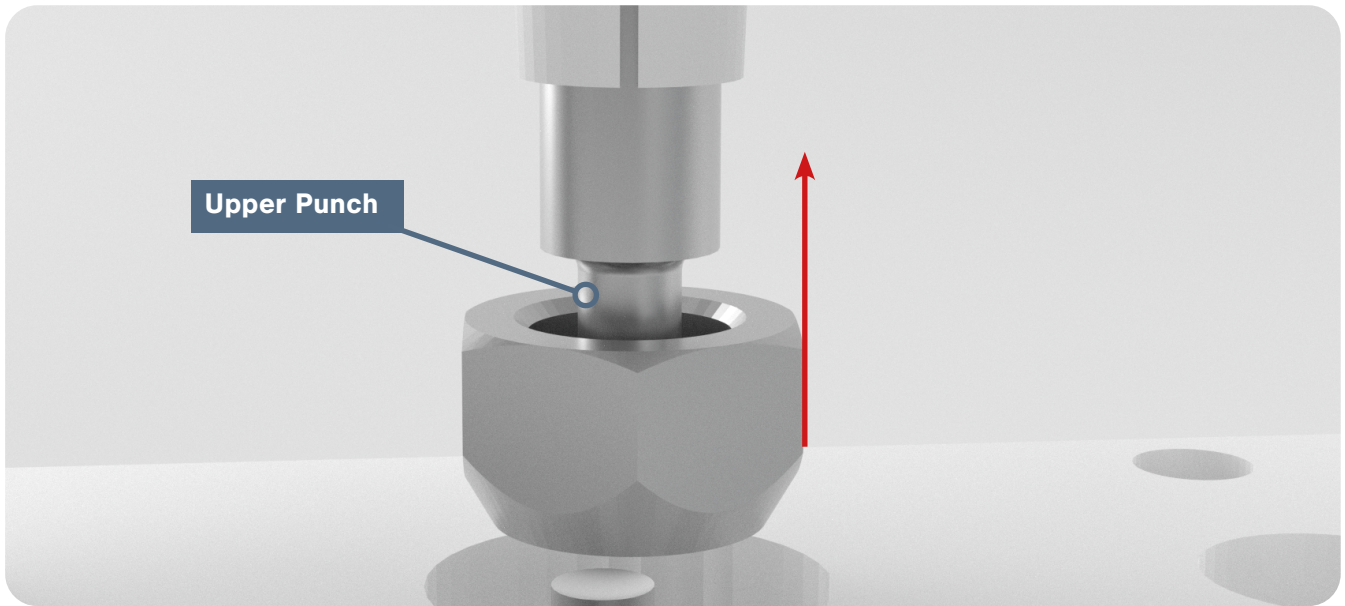

25.1 Note: Rotate the Handle to see that the Upper Punch smoothly enters the Die bore.

- 26. Tighten the Base Plate's bolts with an Allen key.

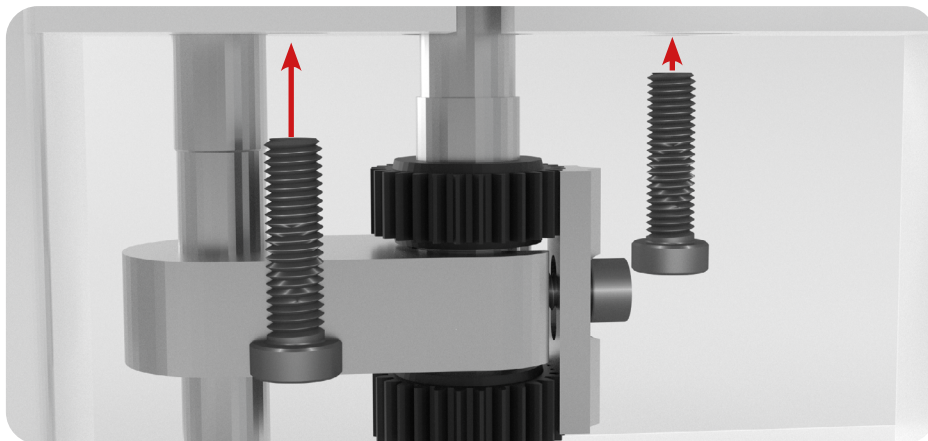

- 27. Position the Boot back on the Base Plate.
- 28. Insert the Boot Timing Bar's end in the Boot
- 29. Resecure the Boot Bolt and Spring underneath the Boot with an Allen key.
- 30. Tighten the Boot's set screw with an Allen key.

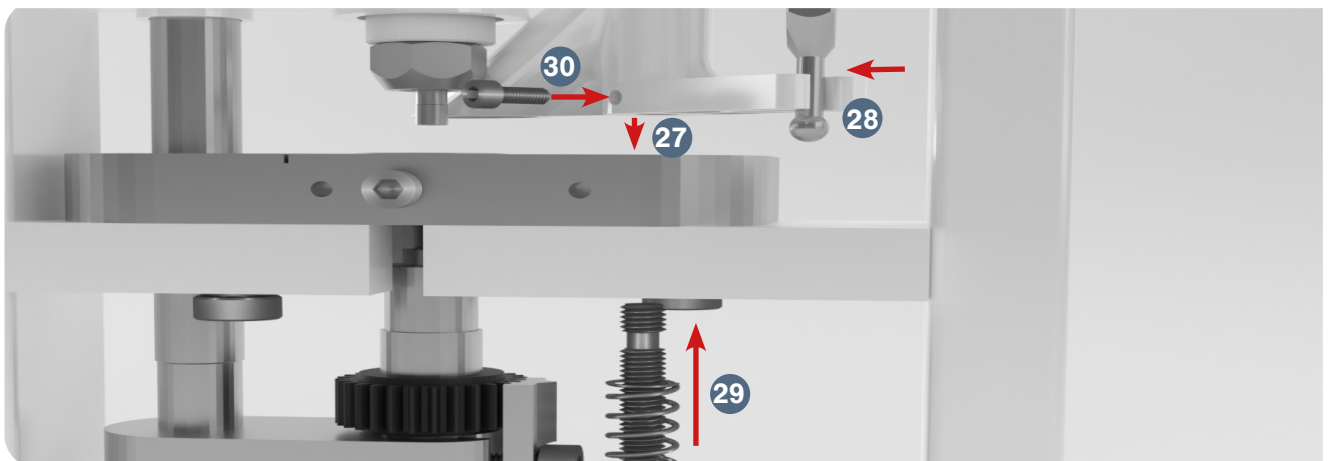

31. Reattach the Ejection Tray with an Allen key.
32. Reinsert the Hopper.

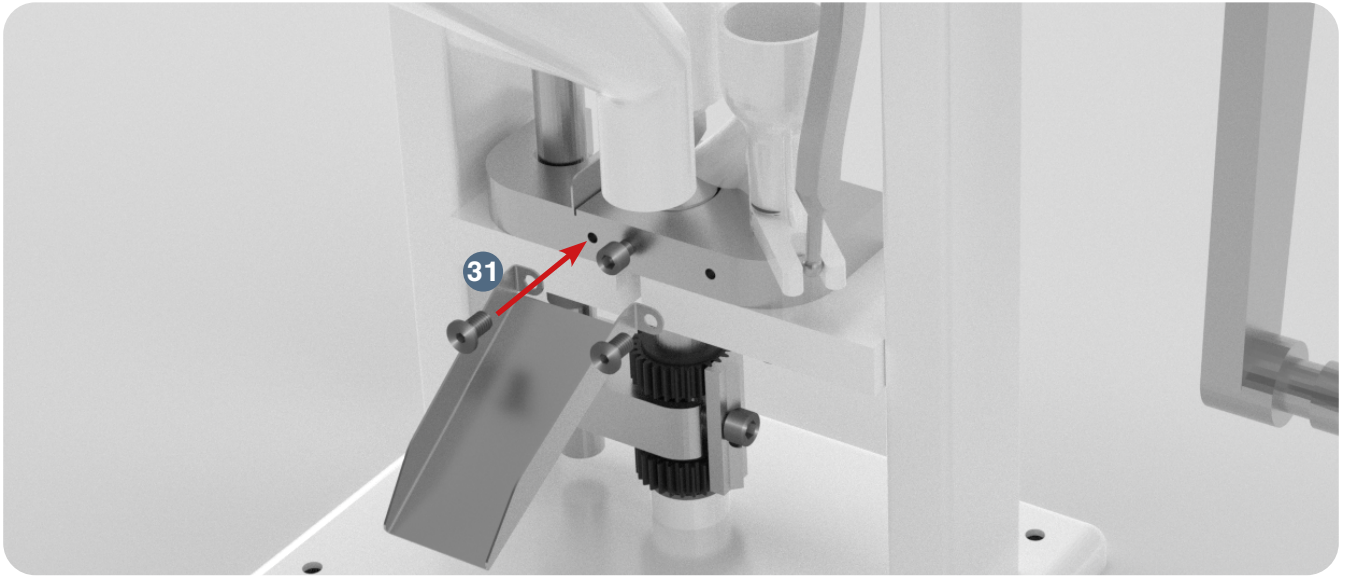

Upper Drift Pin Assembly Rod Eye and Clevis

This part connects the Eccentric Sheave Strap and the Upper Drift Pin Assembly. It can become threaded or warped in the case of accidental collision and can be easily removed and replaced.

Tools and Materials Needed

- Set of metric Allen keys with ball ends
- 24 mm wrenches (2)
- Circlip pliers
- New Upper Drift Pin Assembly Rod Eye and Clevis part
- Disposable latex/rubber gloves (for food grade products and to protect hands from grease)
- Hairnet and/or beard net (food grade products only)
- Sterile shoe covers (food grade products only)



CAUTION: Overtightening bolts and/or screws can damage TDP 0[®] parts.

Instructions

Note: Wear latex/rubber gloves (and appropriate food grade attire if applicable) during this process.

Remove the Upper Drift Pin Assembly Rod Eye and Clevis

1. Remove the Hopper carefully and catch any powder still inside of it.



2. Remove the Ejection Tray with an Allen key.

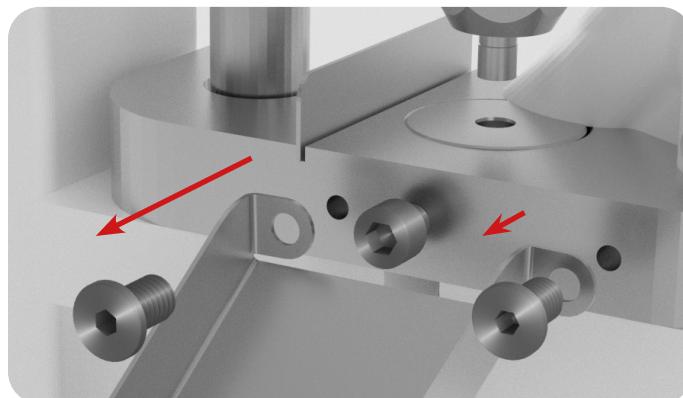

3. Loosen the Boot's set screw with an Allen key.

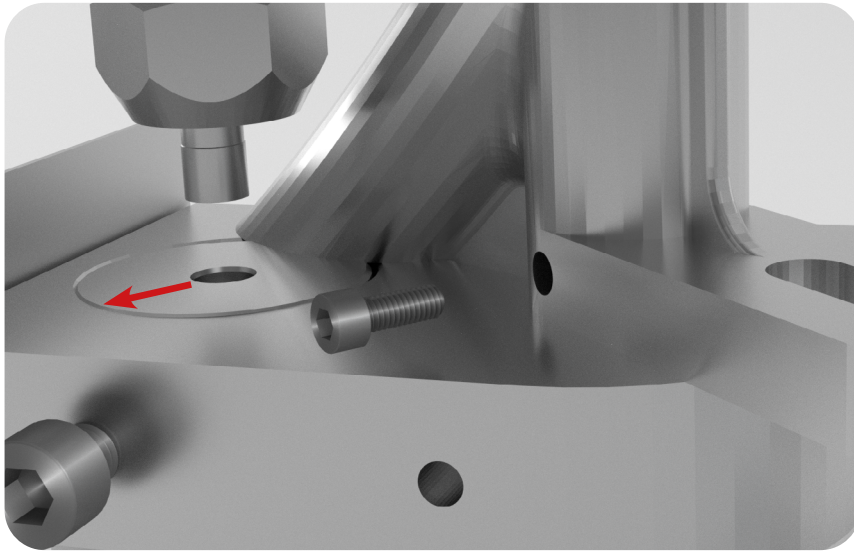

4. Remove the Boot Bolt and Spring underneath the Boot with an Allen key.

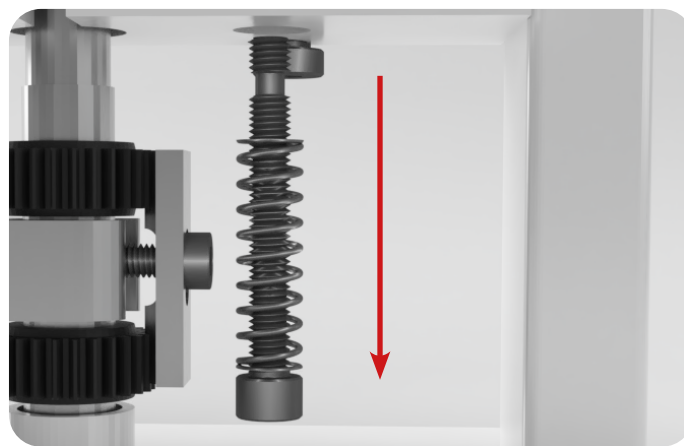

5. Take off the Boot carefully and remove any powder still inside it.

6. Loosen the bolts underneath the Base Plate with an Allen key.

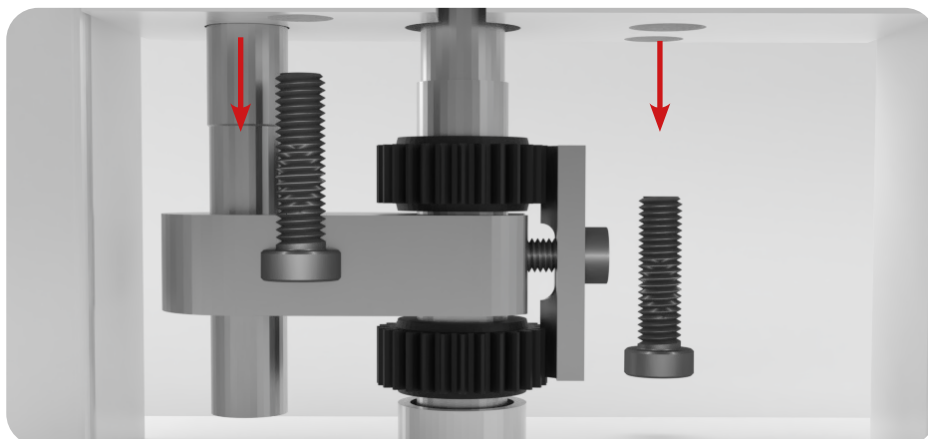

7. Turn the Handle until the Upper Drift Pin Assembly is lowered.
8. Loosen the Upper Punch Locking Nut with a wrench while keeping the Upper Punch Drift Assembly in place with another wrench.
9. Remove the Upper Punch by hand.

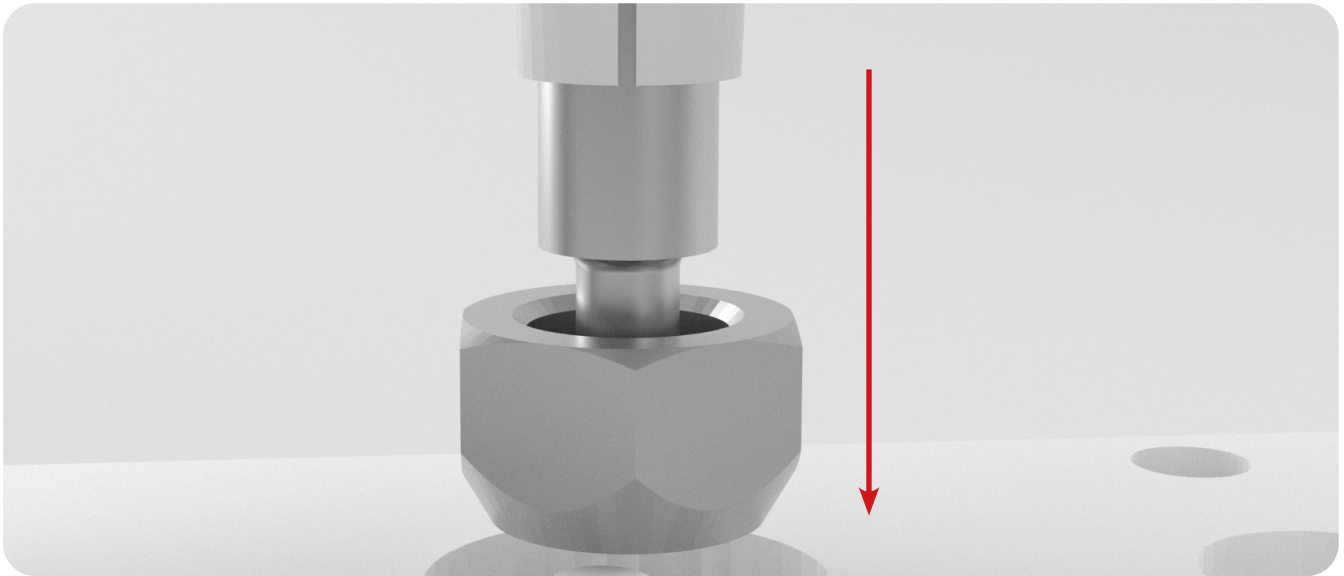

9.1 Note: If you cannot remove by hand, carefully use grippers or pliers.

10. Remove the Base Plate with the Die still inside it.
11. Remove the bolt that locks the Die with an Allen key.
12. Take out the Die from the middle of the Base Plate.
 - 12.1 Lightly tap the Die with a hammer if it is difficult to remove.

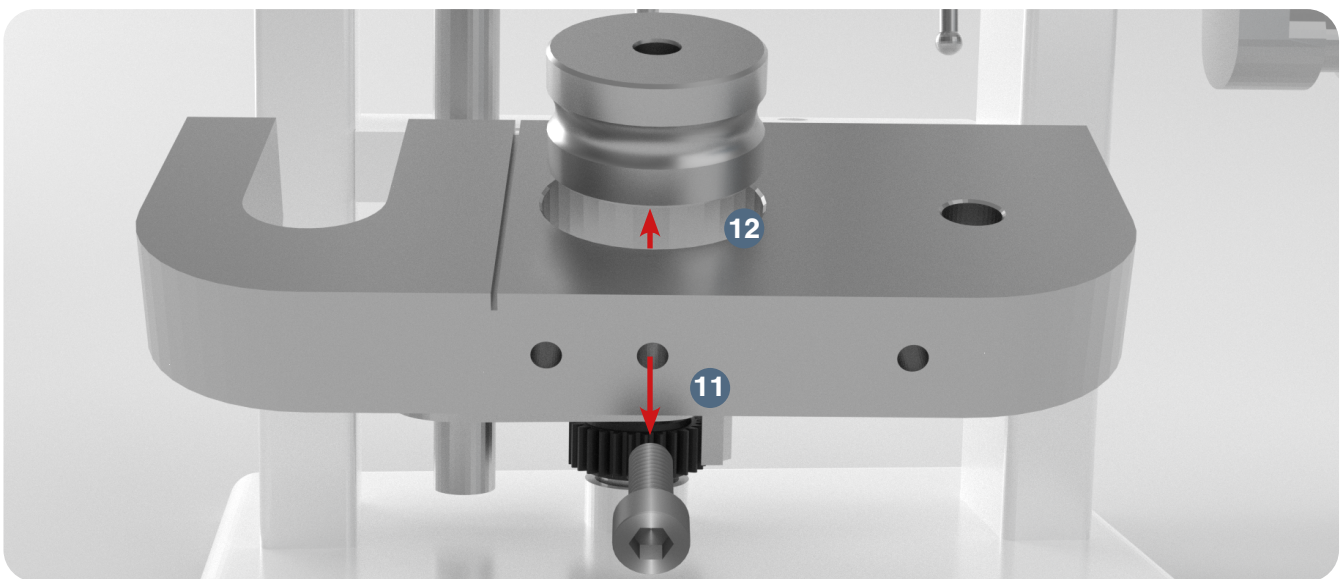

13. Remove the bolt that locks the Lower Punch with an Allen key.
14. Remove the Lower Punch by hand.

15. Loosen the Upper Drift Pin Assembly Locking Nut by hand.
15.1 Note: If you cannot loosen by hand, use a wrench.

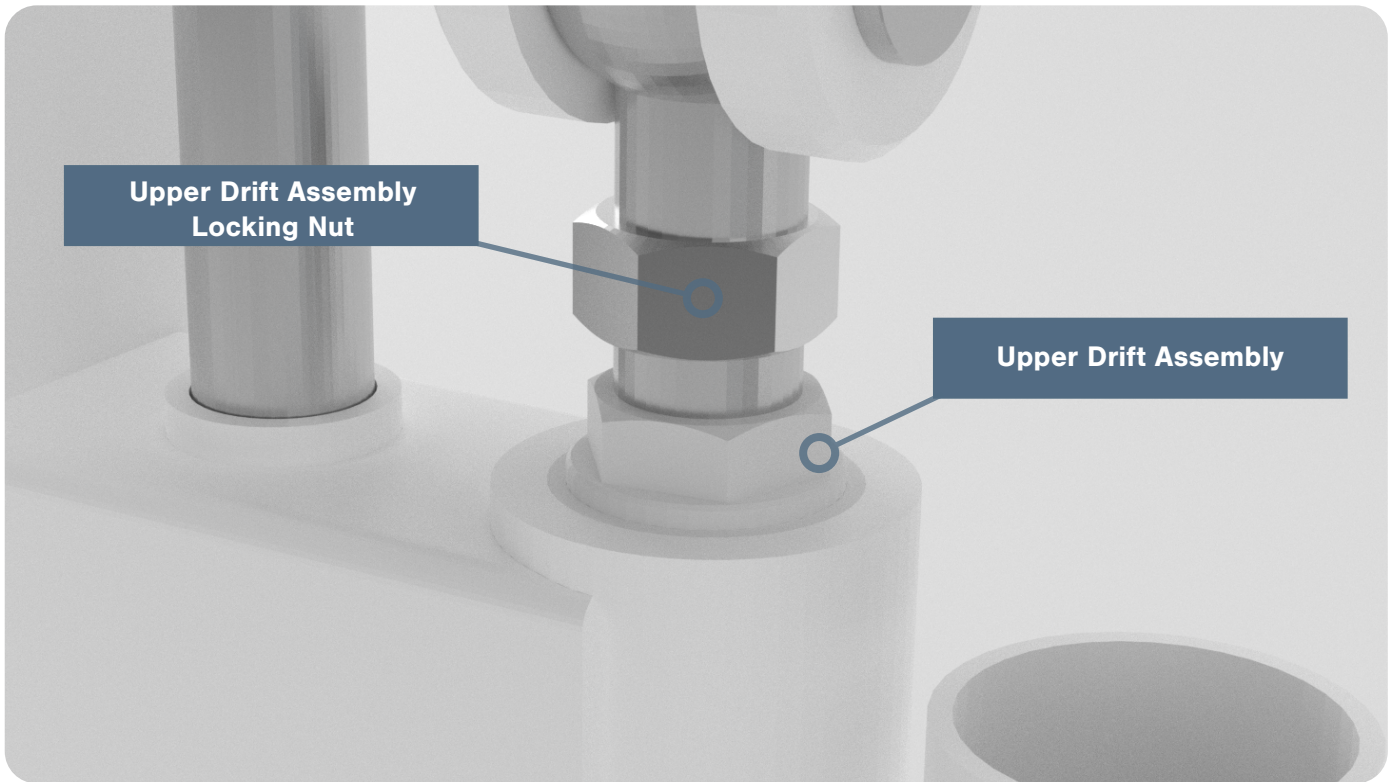

16. Unscrew the Upper Drift Pin Assembly from the Upper Drift Pin Assembly Rod Eye and Clevis.



17. Remove the Upper Drift Pin Assembly Rod Eye and Clevis's circlip with circlip pliers.
18. Remove the Eccentric Sheave Connecting Pin from the Eccentric Sheave Strap.
 - 18.1 Note: Lightly tap the pin with a screwdriver or something similar to aid in its removal.

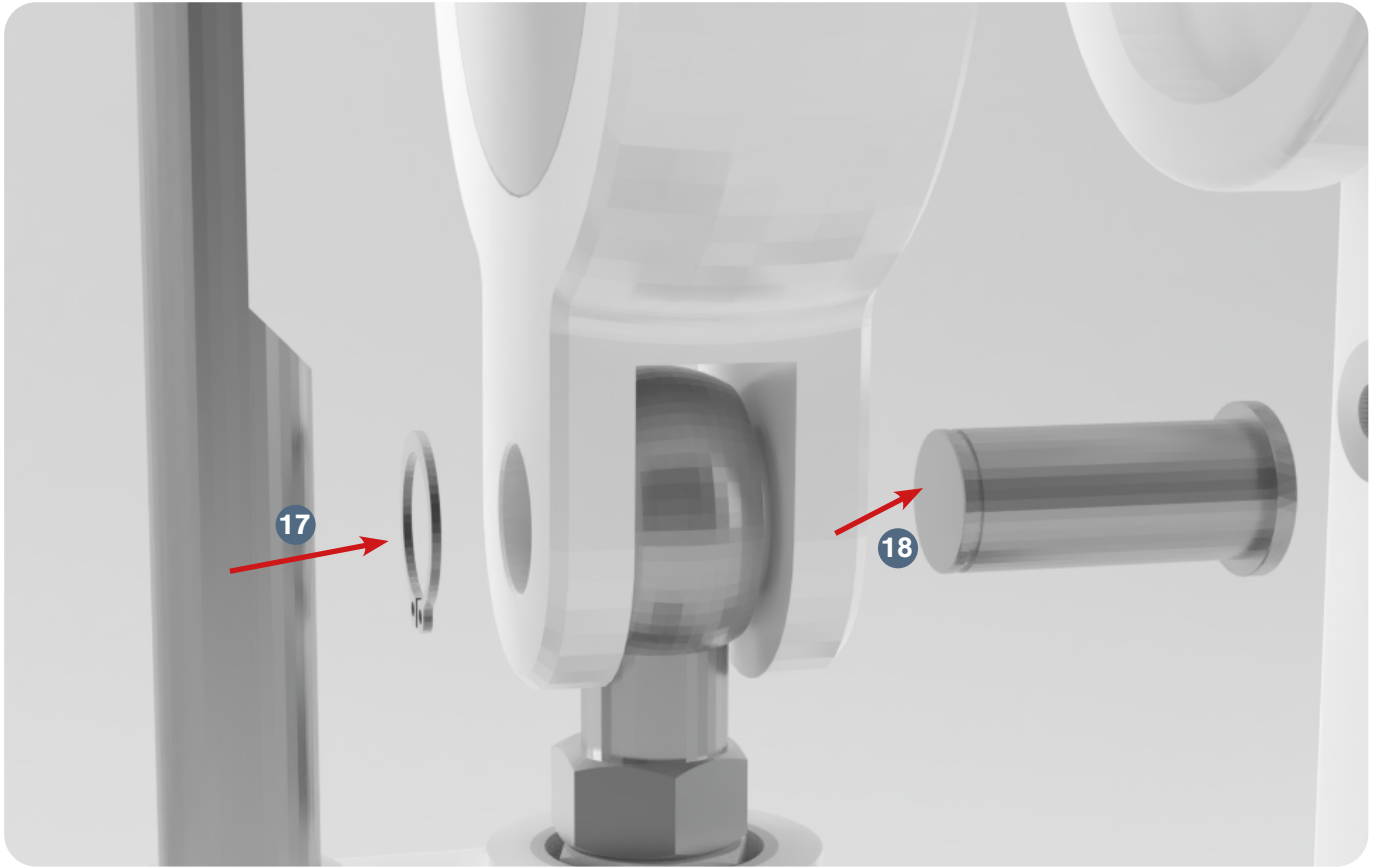

19. Remove the Upper Drift Pin Assembly Rod Eye and Clevis from the Eccentric Sheave Strap.

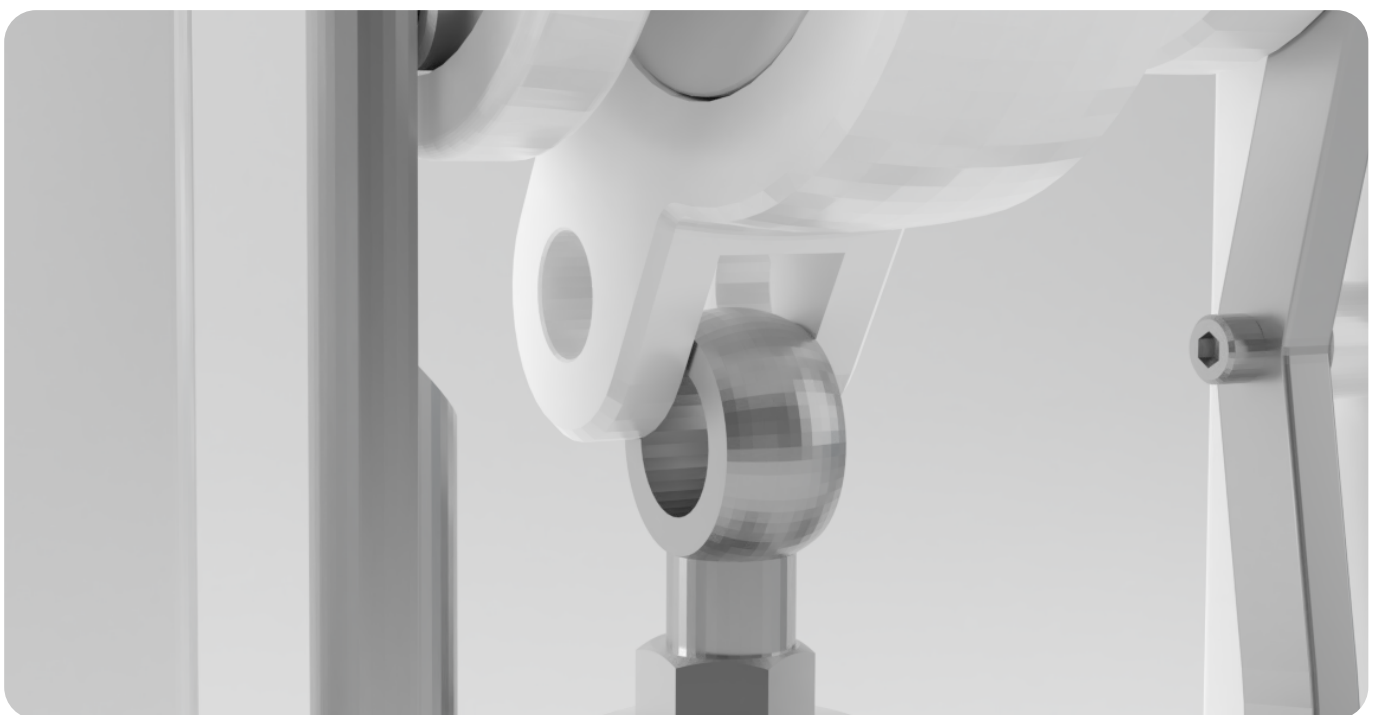

Replace the Upper Drift Pin Assembly Rod Eye and Clevis

20. Reinsert the Eccentric Sheave Connecting Pin and secure it with a circlip.

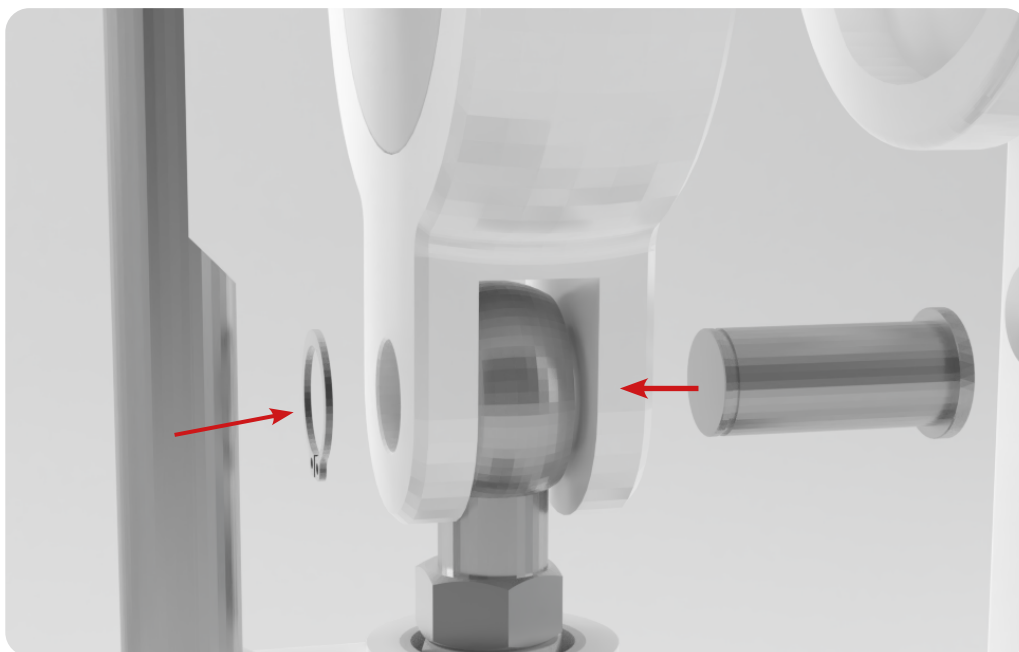

21. Tighten the Upper Drift Pin Assembly Locking Nut onto the new Upper Drift Pin Assembly Rod Eye and Clevis by hand or with a wrench.

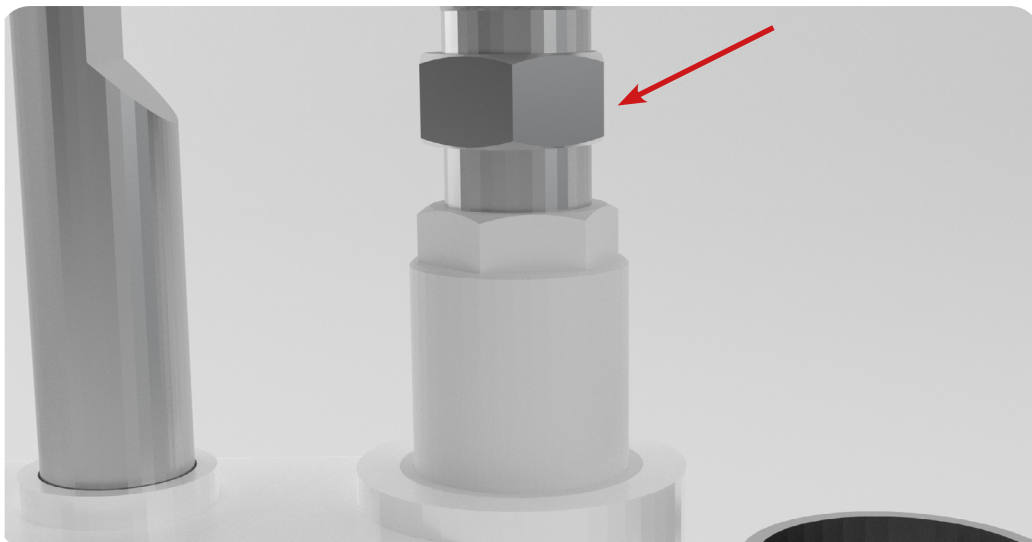

22. Screw the Upper Drift Pin Assembly onto the new Upper Drift Pin Assembly Rod Eye and Clevis.

- 23. Reinsert the Lower Punch into the Lower Drift Pin Assembly.
- 24. Reinsert the bolt that locks the Lower Punch with an Allen key.

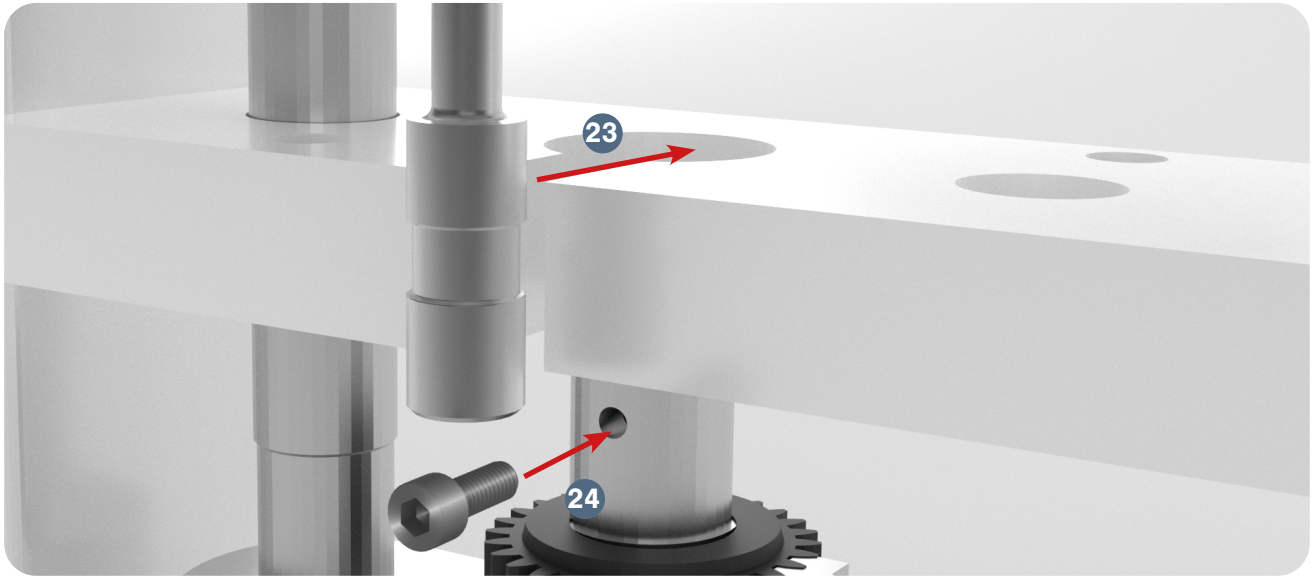

24.1 Note: Make sure that the Lower Punch's “keyed” section is facing forward.

- 25. Place the Base Plate onto the TDP 0® Base.
- 26. Insert the Die into the middle of the Base Plate.
- 27. Reinsert the bolt that locks the Die with an Allen key.

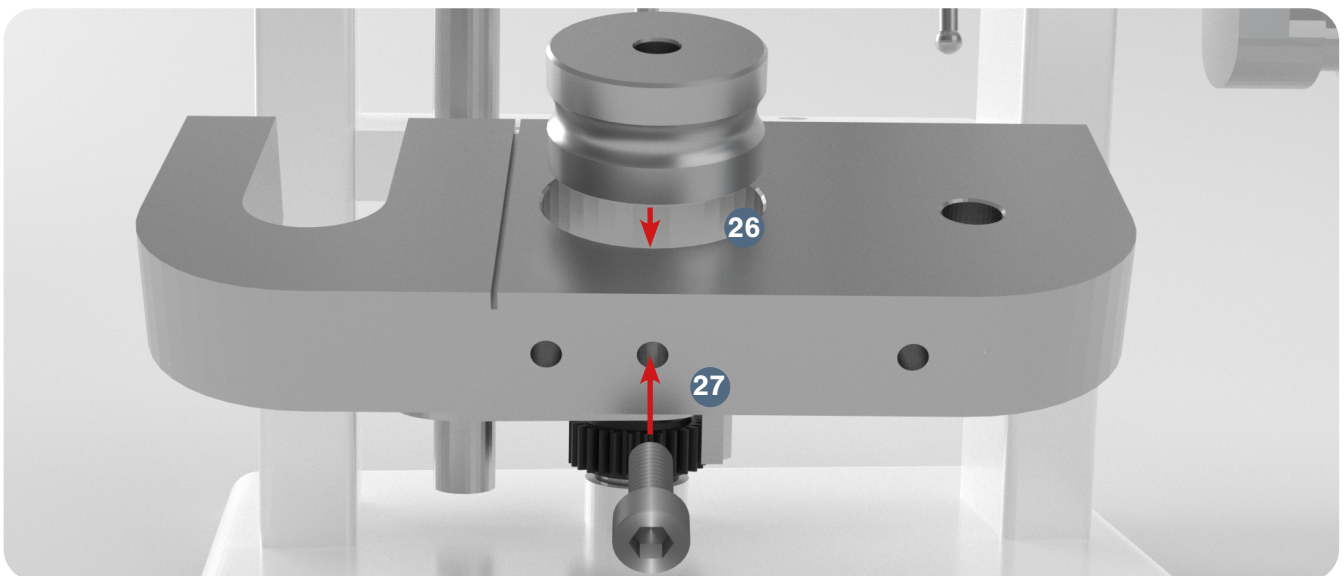

- 28. Insert the Upper Punch into the Upper Drift Pin Assembly.
- 29. Tighten the Upper Punch Locking Nut onto the Upper Drift Pin Assembly with a wrench.

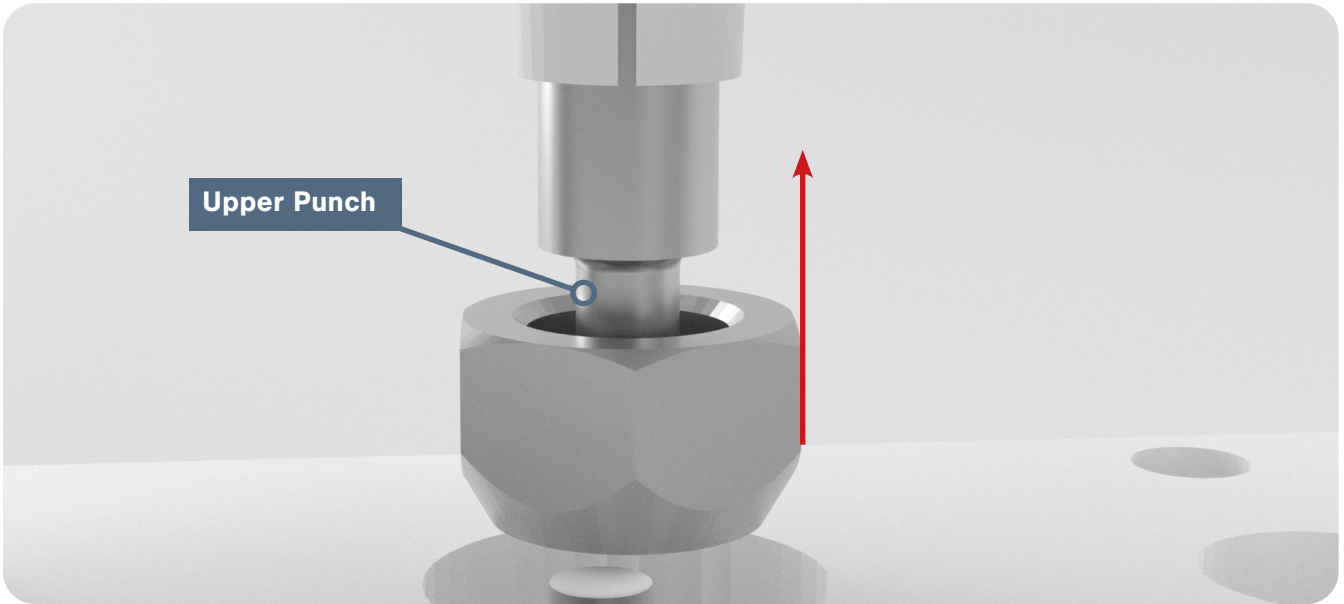

29.1 Note: Rotate the Handle to see that the Upper Punch smoothly enters the Die bore.

- 30. Tighten the Base Plate's bolts with an Allen key.

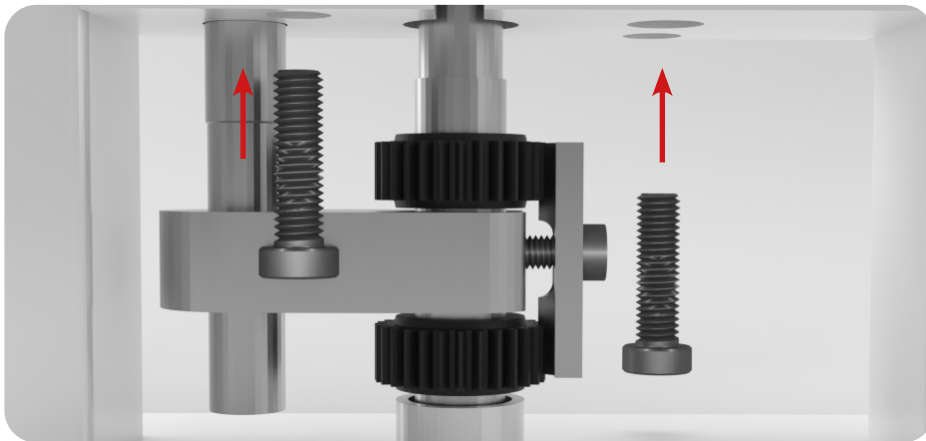

- 31. Position the Boot back on the Base Plate.
- 32. Insert the Boot Timing Bar's end in the Boot
- 33. Resecure the Boot Bolt and Spring underneath the Boot with an Allen key.
- 34. Tighten the Boot's set screw with an Allen key.

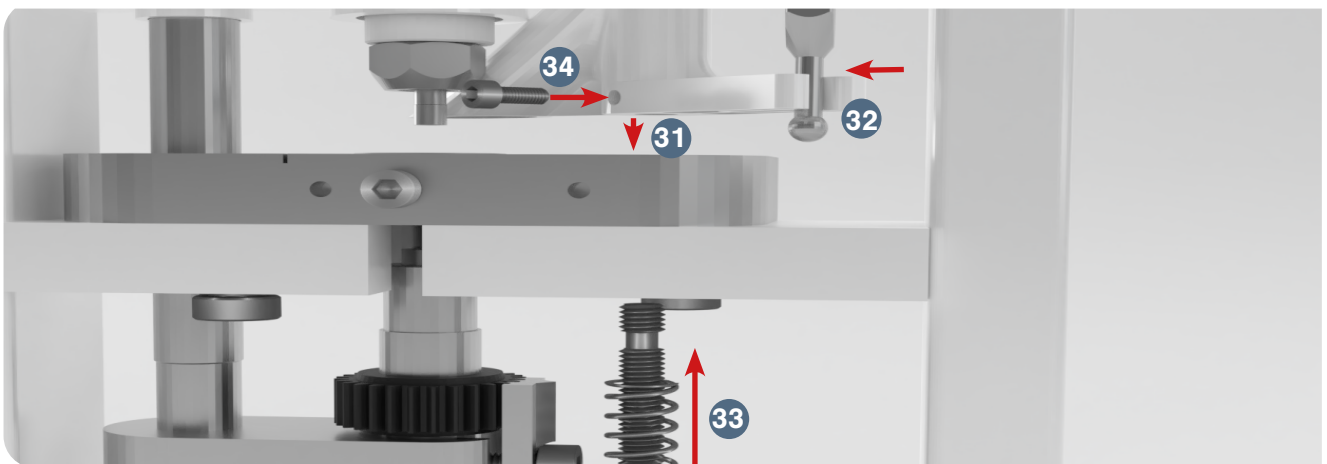

- 35. Reattach the Ejection Tray with an Allen key.
- 36. Reinsert the Hopper.

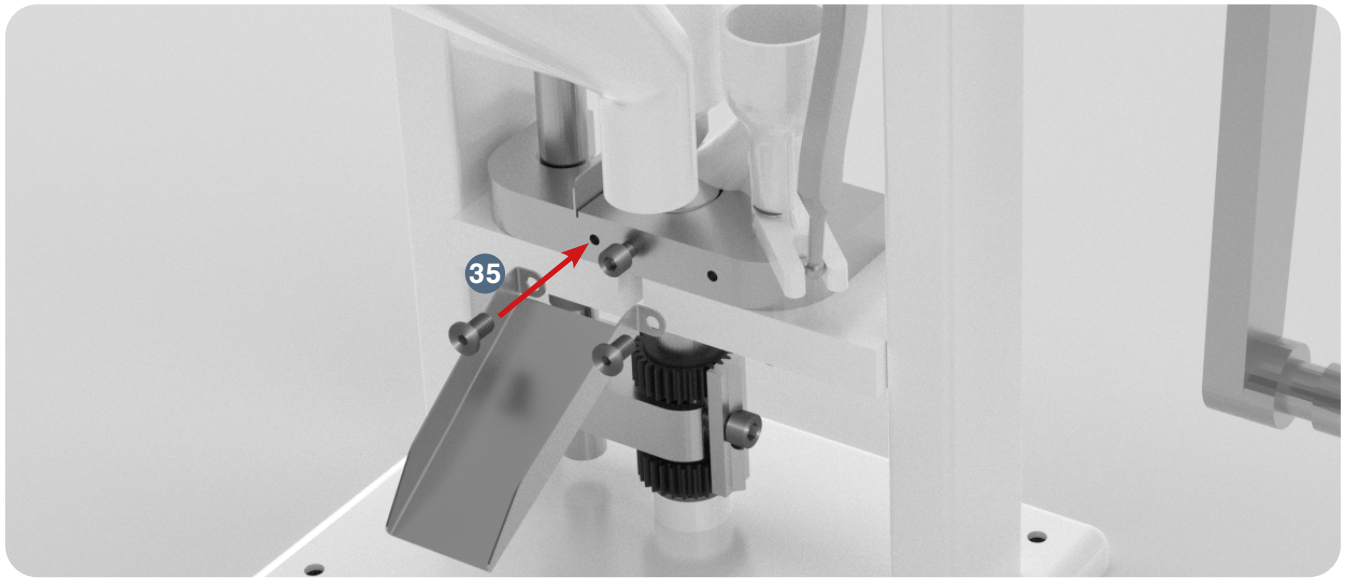

Lower Drift Pin Assembly

The Lower Drift Pin Assembly may need to be removed if any punches become stuck inside it and/or the Lower Drift Pin Assembly Cogs become jammed on it.

Tools and Materials Needed

- Set of metric Allen keys with ball ends
- 24 mm wrenches (2)
- New Lower Drift Pin Assembly part
- Disposable latex/rubber gloves (for food grade products and to protect hands from grease)
- Hairnet and/or beard net (food grade products only)
- Sterile shoe covers (food grade products only)



CAUTION: Overtightening bolts and/or screws can damage TDP 0 parts.

Instructions

Note: Wear latex/rubber gloves (and appropriate food grade attire if applicable) during this process.

Remove the Lower Drift Pin Assembly

1. Remove the Hopper carefully and catch any powder still inside of it.



2. Remove the Ejection Tray with an Allen key.

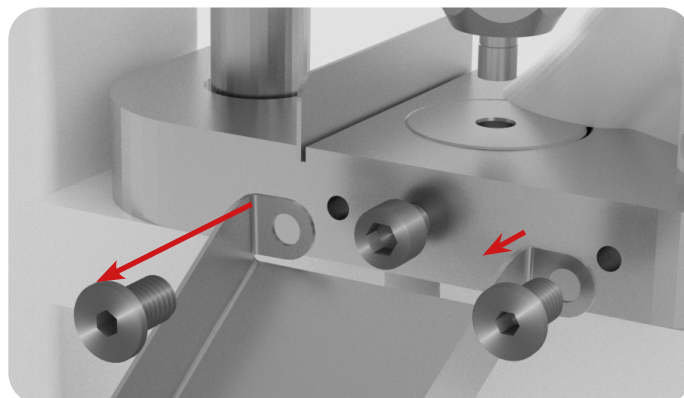

3. Loosen the Boot's set screw with an Allen key.

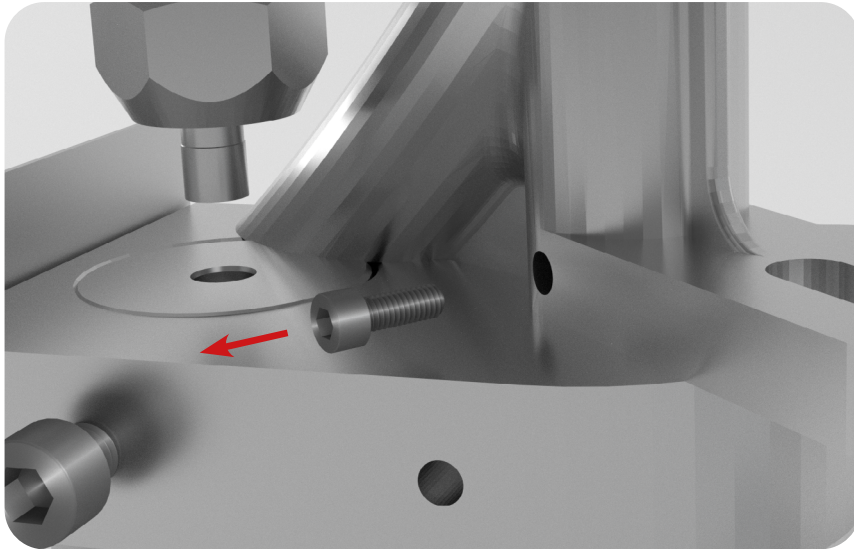

4. Remove the Boot Bolt and Spring underneath the Boot with an Allen key.

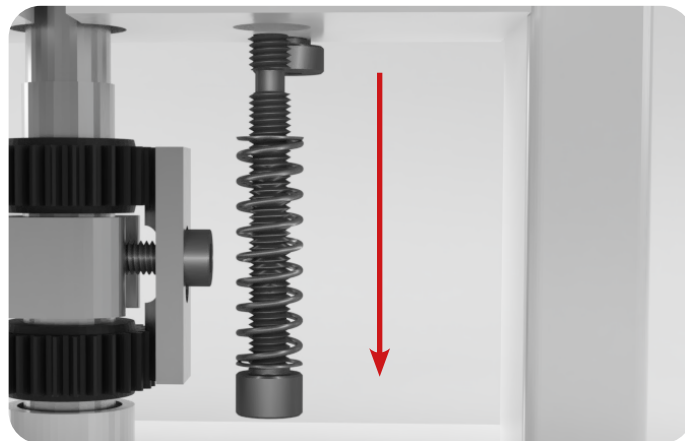

5. Take off the Boot carefully and remove any powder still inside it.

6. Loosen the bolts underneath the Base Plate with an Allen key.

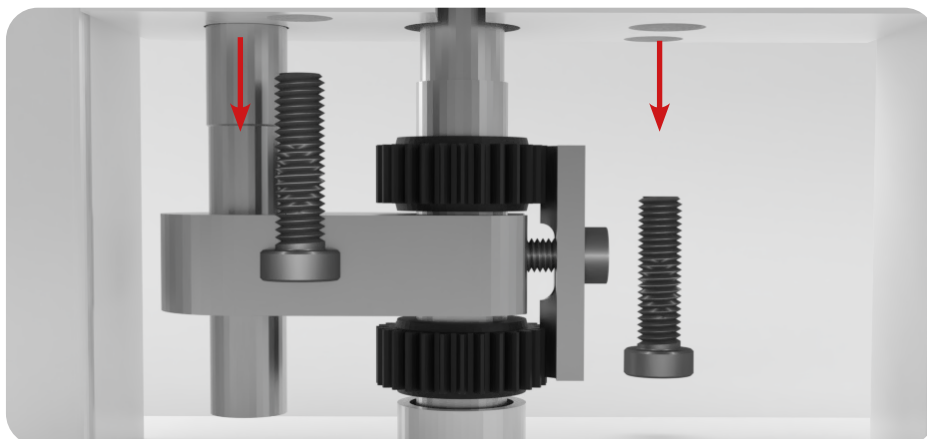

7. Remove the Base Plate with the Die still inside it.
8. Remove the bolt that locks the Die with an Allen key.
9. Take out the Die from the middle of the Base Plate.
 - 9.1 Lightly tap the Die with a hammer if it is difficult to remove.

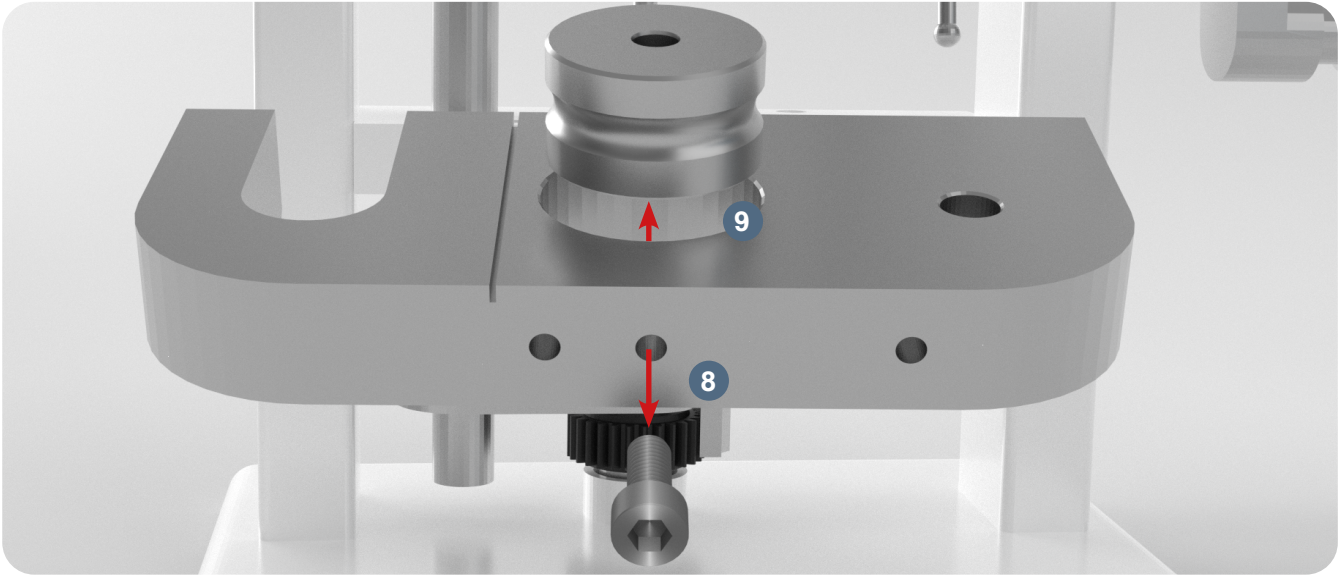

10. Remove the bolt that locks the Lower Punch with an Allen key.
11. Remove the Lower Punch by hand.

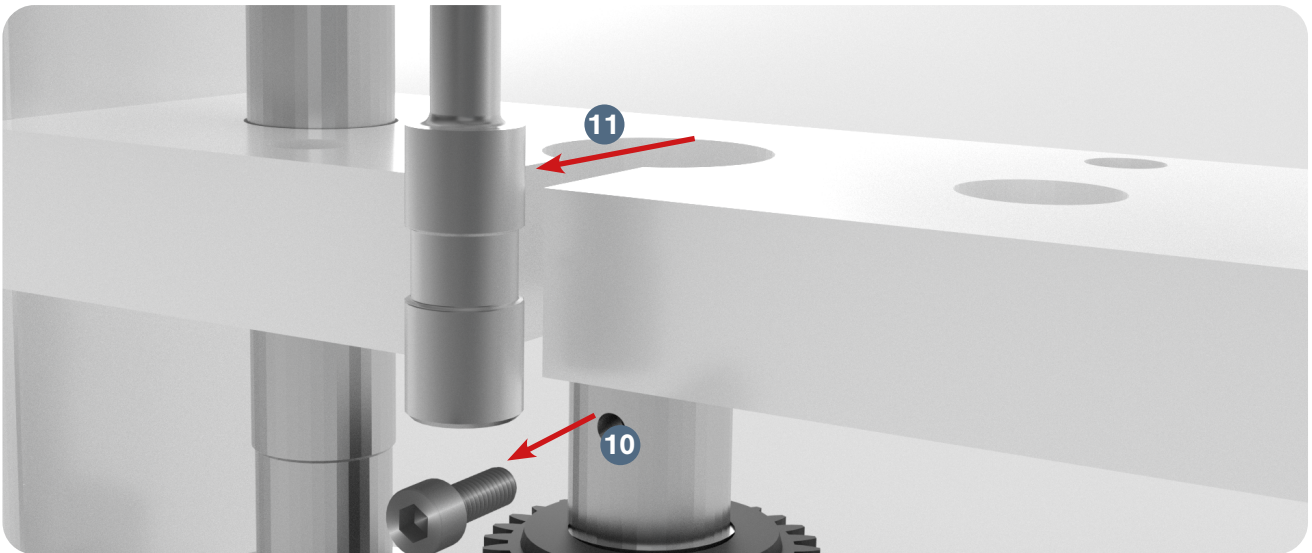

11.1 Note: If you cannot remove by hand, carefully use grippers or pliers.

12. Remove the Lower Drift Pin Assembly Locking Bar with an Allen key.

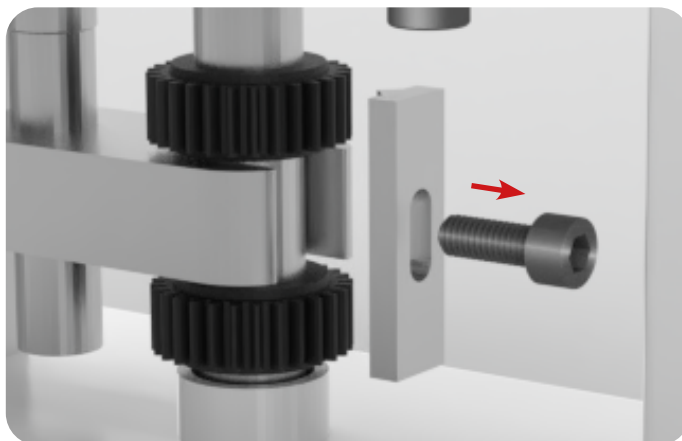

13. Rotate the Lower Drift Pin Assembly Cogs to remove them from the Lower Drift Pin Assembly.

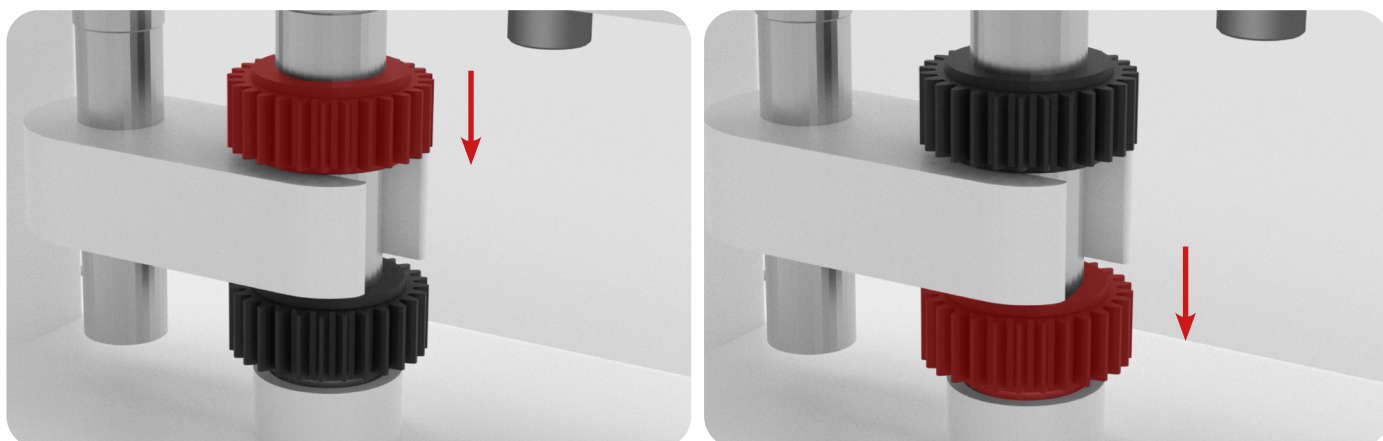

14. Remove the Lower Drift Pin Assembly from the Lower Drift Pin Assembly Lifting Bar and Base.

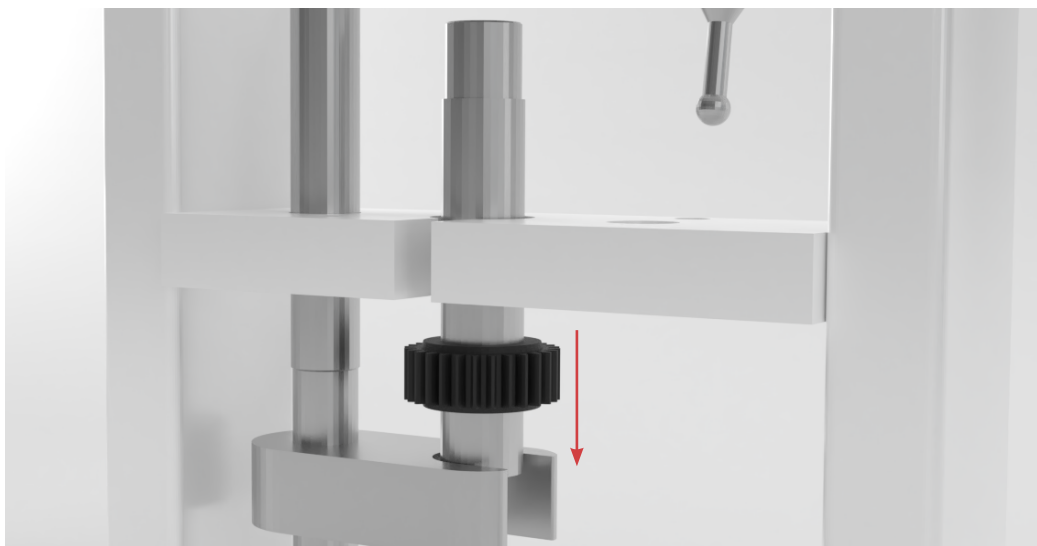

Replace the Lower Drift Pin Assembly

15. Rotate one of the Lower Drift Pin Assembly Cogs onto the new Lower Drift Pin Assembly.

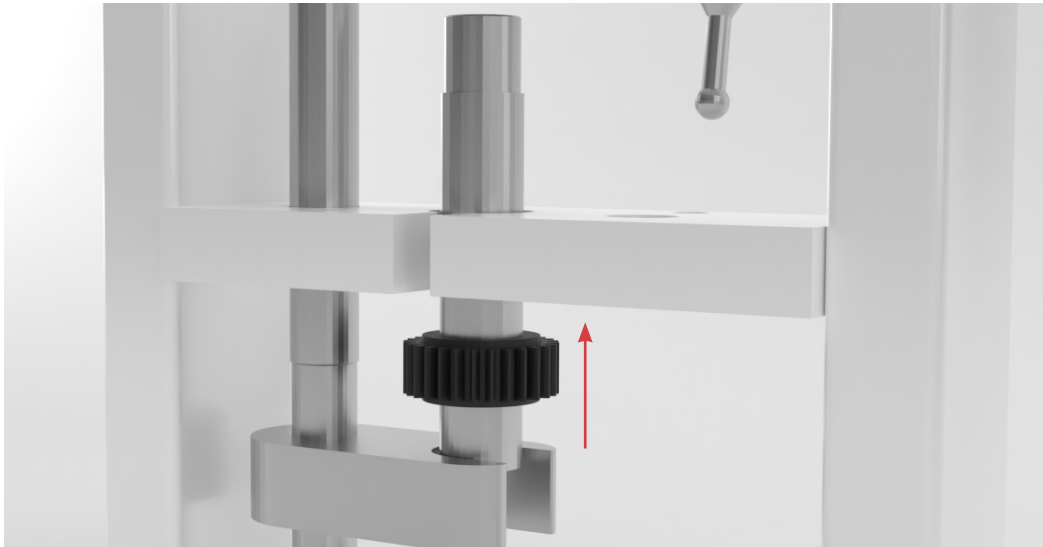

16. Raise the Lower Drift Pin Assembly Cog just below the bolt bore on the Lower Drift Pin Assembly.



17. Insert the new Lower Drift Pin Assembly into the Base and the Lower Drift Pin Assembly Lifting Bar.

18. Rotate the remaining Lower Drift Pin Assembly Cog onto the Lower Drift Pin Assembly below the Lower Drift Pin Assembly Timing Bar.

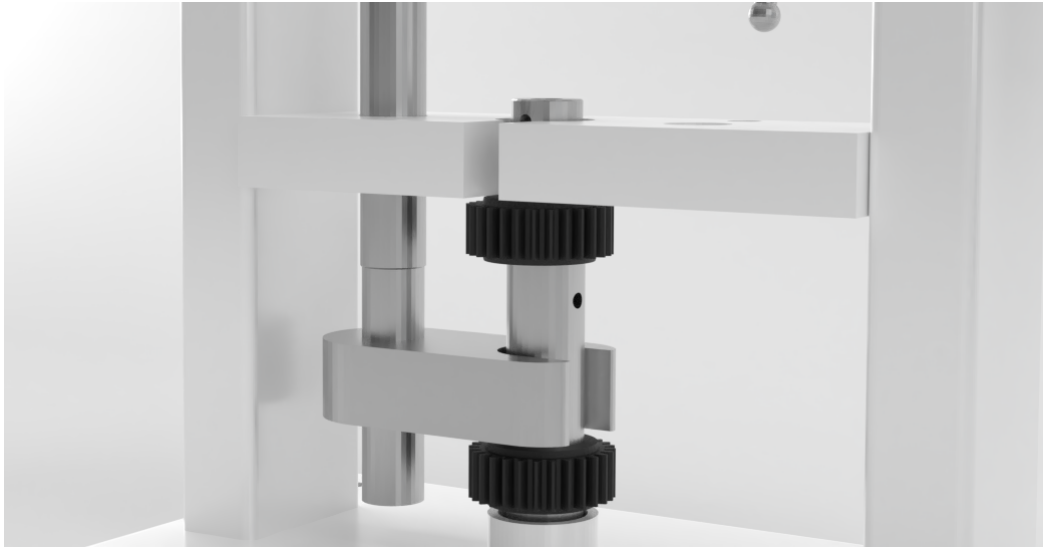

19. Rescrew the bolt into the Lower Drift Pin Assembly Lifting Bar with an Allen key.

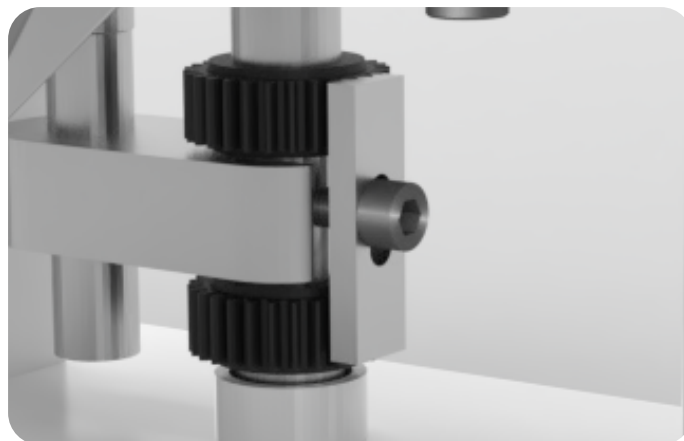

19.1 Note: Ensure that the Lower Drift Pin Assembly Locking Bar is situated vertically.

- 20. Reinsert the Lower Punch into the new Lower Drift Pin Assembly.
- 21. Reinsert the bolt that locks the Lower Punch with an Allen key.

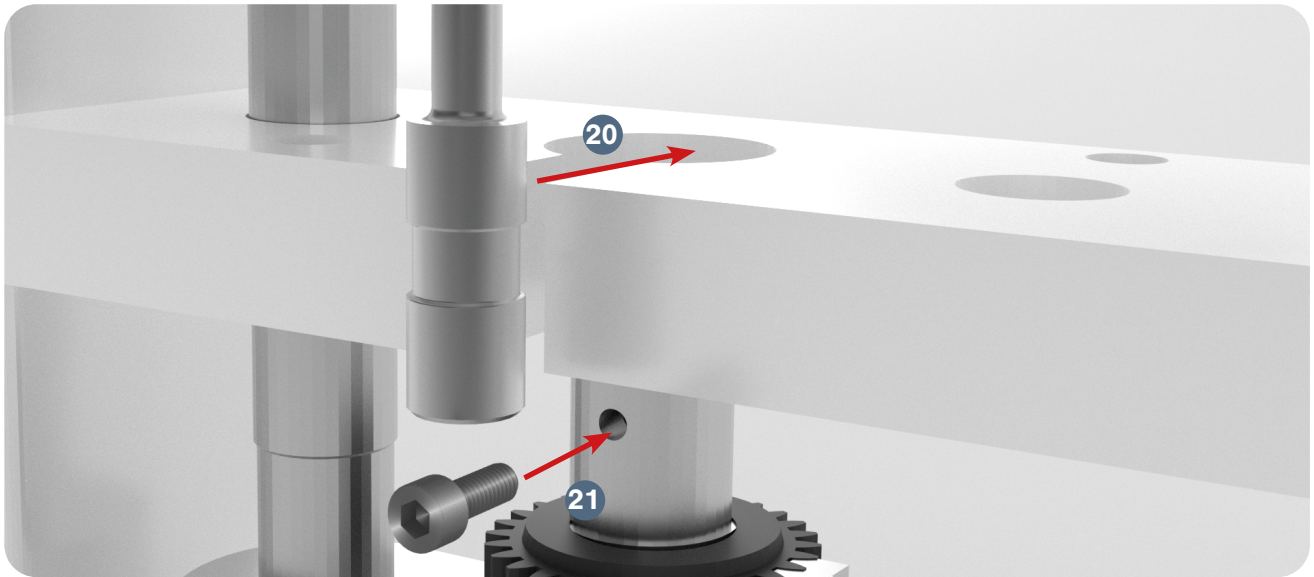

20.1 Note: Make sure that the Lower Punch's "keyed" section is facing forward.

- 22. Place the Base Plate onto the TDP 0[®] Base.
- 23. Reinsert the Die into the middle of the Base Plate.
- 24. Reinsert the bolt that locks the Die with an Allen key.

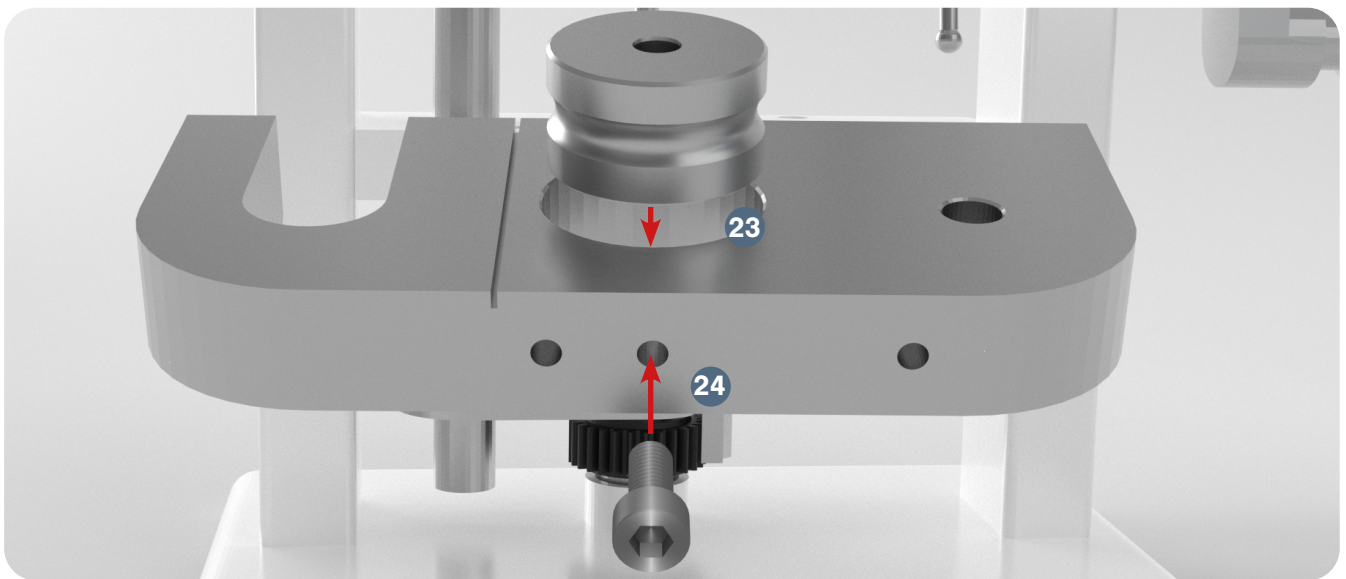

24.1 Note: Rotate the Handle to see that the Upper Punch smoothly enters the Die bore.

25. Tighten the Base Plate's bolts with an Allen key.

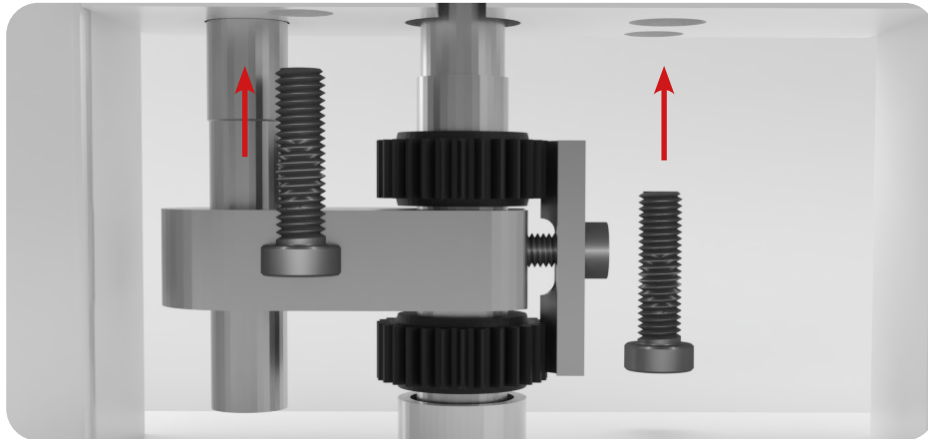

26. Position the Boot back on the Base Plate.

27. Insert the Boot Timing Bar's end in the Boot

28. Resecure the Boot Bolt and Spring underneath the Boot with an Allen key.

29. Tighten the Boot's set screw with an Allen key.

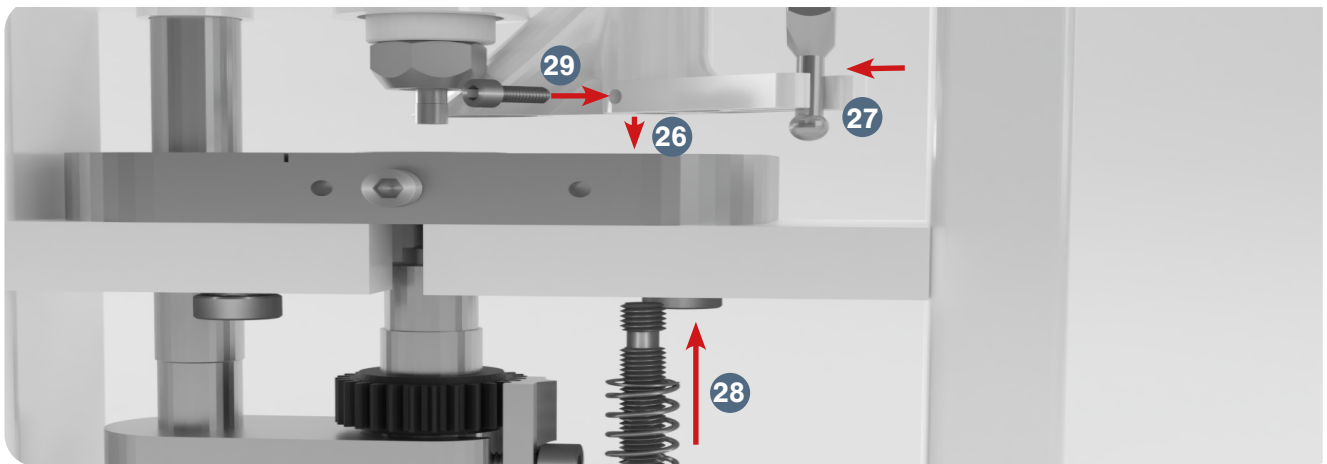

30. Reattach the Ejection Tray with an Allen key.

31. Reinsert the Hopper.

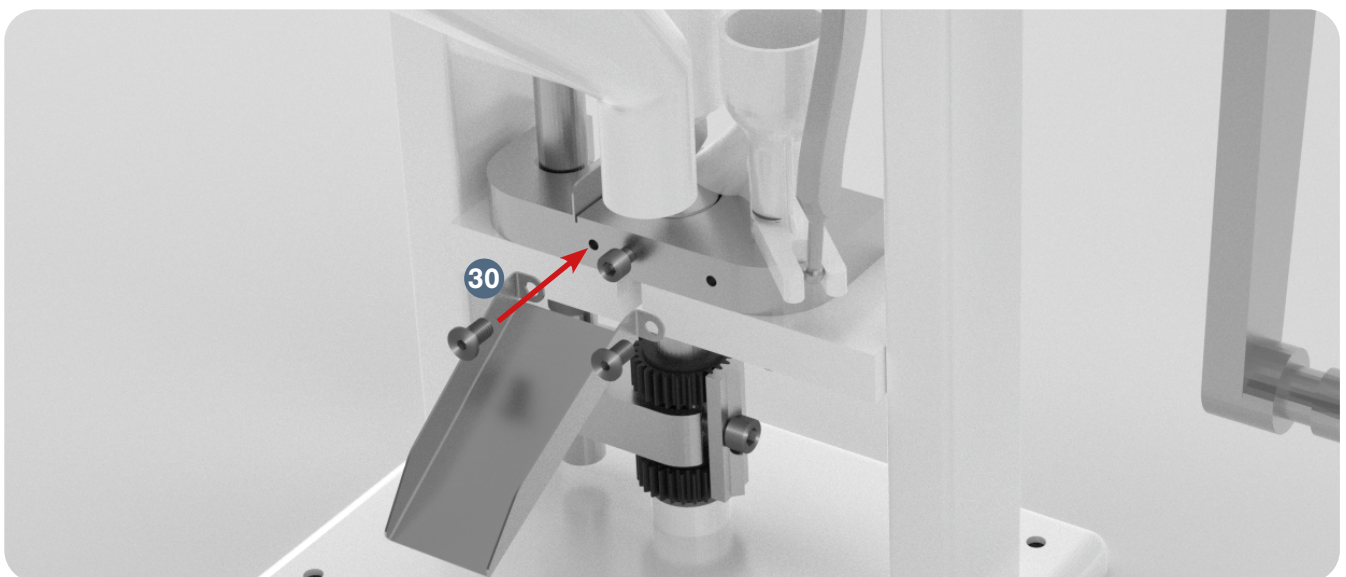

Troubleshooting

Sometimes problems will occur while operating the TDP 0[®]. Fortunately, there are several methods to remedy these issues.

Common Machine/Part Issues

Symptom	Possible Cause	Possible Solution
Machine freezes or locks up	Grease point areas are dry.	Regularly oil and grease all the Grease Nipple points.
	There is excess pressure on the Upper Drift Pin Assembly.	Rotate the Upper Drift Pin Assembly counterclockwise.
	The press is being started with the Upper Punch at a low point.	Adjust the starting position so that the Upper Punch is at the highest point.
Knocking sounds coming from machine	The Upper Punch and Lower Punch are colliding with the Die.	After loosening its bolts, readjust the Base Plate until it is correctly aligned. After that, tighten the bolts back.
	The Upper Drift Pin Assembly is slightly off.	Loosen the Base Plate bolts and rotate the machine until the Upper Punch is aligned with the Die's bore. After that, tighten the bolts back.
	The Upper Drift Pin Assembly is not dropping smoothly in the powder filling stage of the process.	Check that there is not a buildup of powder between the Lower Punch and the Die. Then check that the Lower Drift Pin Assembly has enough clearance to drop through the hole in the Base.
Heavy resistance during production	The high friction areas are either unclean, locked, worn out, or not greased properly.	Apply grease to the Grease Nipple points and all high friction areas on the machine.

Symptom	Possible Cause	Possible Solution
Inability to compact materials to tablet form	Boot is blocked and not enough materials are flowing out.	Check the Boot for a potential clog.
	The Boot Timing Bar is not secured.	Tighten the Boot Timing Bar's nuts and bolt.
	There is not enough pressure.	Rotate the Upper Drift Pin Assembly clockwise.
	The Lower Punch is broken.	Remove the Lower Drift Pin Assembly to access the broken Lower Punch. After removing it, replace the Tooling.
	The Lower Drift Pin Assembly is not dropping properly during filling.	Check that there is not a buildup of powder between the Lower Punch and the Die. Then check that the Lower Drift Pin Assembly has enough clearance to drop through the hole in the base.
	There are flowing issues with the mix.	If the machine is able to make tablets with LFA's Firmapress®, then the problem is your mix. Adjust your formulation. If still an issue, contact LFA for support.
Powder sticks to the Upper Punch	There is damage to the Tooling or the Tooling's design is causing sticking.	Remove and replace the Tooling (Upper Punch, Lower Punch, and Die).
	There are issues with the mix.	Adjust your formulation. If still an issue, contact LFA for support.
Powder sticks to the Lower Punch	There are issues with the mix.	Adjust your formulation. If still an issue, contact LFA for support.

Common Tablet Issues

Symptom	Possible Cause	Possible Solution
Double tablets	Previous tablet did not eject correctly.	Remove the double tablet manually from the Die bore.
	Excess granular materials were placed in the Die, which prevented the ejection of the existing tablet.	Clean the Tooling to remove any excess granular materials and make sure that it is clean and completely dry.
Cracked or broken tablets	There are problems with the formulation of the granules and ingredients.	If the machine is able to make tablets with LFA's Firmapress®, then the problem is your mix. Adjust your formulation. If still an issue, contact LFA for support.
	The Boot is not feeding enough material to be pressed in tablet form.	
	There is excess pressure.	Please read our article on Capping at https://www.lfatabletpresses.com/articles/tablet-capping
Shattered tablets	The Boot Timing Bar and the Boot are not adjusted properly.	Adjust the Boot Timing Bar by loosening/tightening its bolt and moving it.
	Air is becoming trapped in the tablet during compression.	Please read our article on Capping at https://www.lfatabletpresses.com/articles/tablet-capping
Inconsistent Tablet Weight	The Lower Drift Pin Assembly Locking Bar is loose.	Check that the Lower Drift Pin Assembly Locking Bar is secured to the Lower Drift Pin Assembly and the Lower Drift Pin Assembly Cogs.
	Not enough pressure is being exerted.	Rotate the Upper Drift Pin Assembly clockwise.
	There are flowing issues with the mix.	If the machine is able to make tablets with LFA's Firmapress®, then the problem is your mix. Adjust your formulation. If still an issue, contact LFA for support.
Soft tablets	There is too little punch pressure.	Rotate the Upper Drift Pin Assembly clockwise.
	There are flowing issues with the mix.	If the machine is able to make tablets with LFA's Firmapress®, then the problem is your mix. Adjust your formulation. If still an issue, contact LFA for support.
Uneven tablets	The Tooling is worn out.	Check the ingredients of your formula before you replace the Die, Upper Punch, and Lower Punch.

De-jamming the TDP 0[®]

There are several reasons why a TDP 0[®] might jam such as:

- The fill depth is set too low and the pressure is set too high.
- There is a build up of powder sticking to the Tooling.
- Any powder buildup on the machine can cause tablets to eject backwards and not forwards, creating potential for a double tablet becoming stuck in the Die's bore.

The two methods that can fix a jammed TDP 0[®] follow below:



CAUTION: Overtightening bolts and/or screws can damage TDP 0[®] parts.

Tools and Materials Needed

- Set of metric Allen keys with ball ends
- Hammer (if Die is difficult to remove)
- Cleaning brush
- 13 mm wrench
- Disposable latex/rubber gloves (for food grade products and to protect hands from grease)
- Hairnet and/or beard net (food grade products only)
- Sterile shoe covers (food grade products only)

Instructions

Note: Wear latex/rubber gloves (and appropriate food grade attire if applicable) during this process.

Method 1: Run a Reverse Rotation

Note: Please refer to the Dimantling for Repair and Replacement section for additional assistance.

1. Remove the Hopper carefully and catch any powder that is inside of it.
2. Loosen the Boot's set screw with an Allen key.
3. Remove the Boot Bolt and Spring underneath the Boot with an Allen key.
4. Take off the Boot carefully and remove any powder that is inside of it.
5. Turn the TDP 0[®]'s Handle in the reverse direction for a few rotations.
6. Reposition the Boot on the Base Plate correctly.
7. Resecure the Boot Bolt and Spring underneath the Boot with an Allen key.
8. Insert the Boot Timing Bar's end in the Boot
9. Tighten the Boot's set screw with an Allen key.
10. Tighten the Boot Timing Bar bolt with an Allen key.
11. Tighten the Boot Timing Bar bolt's nuts with a wrench.

Method 2: Clean the Tooling

Note: More details can be found in the Cleaning section of this manual.

1. Remove excess powder and any tablets from the Ejection Tray.
 - 1.1 Note: Use the cleaning brush to ensure that all debris is gone.
2. Remove the Ejection Tray with an Allen key.
3. Loosen the Boot Timing Bar bolt's nuts with a wrench.
4. Loosen the Boot Timing Bar bolt with an Allen key.
5. Remove the Boot Timing Bar's end from the Boot.
6. Loosen the Boot's set screw with an Allen key.
6. Remove the Boot Bolt and Spring underneath the Boot with an Allen key.
7. Take off the Boot carefully and remove any powder that is inside of it.
8. Loosen the bolt underneath the Base Plate with an Allen key.
9. Remove the Base Plate with the Die still inside it.
10. Remove the bolt that locks the Die with an Allen key.
11. Take out the Die from the middle of the Base Plate.
 - 11.1 Note: Lightly tap the Die with a hammer if it is difficult to remove.
13. Poke out any packed-in powder in the Die bore and remove any excess powder.
14. Insert the Die into the Base Plate and reattach the bolt to the Base with an Allen key.
15. Rescrew the Die set screw with an Allen key.
16. Position the Boot back on the Base Plate.
17. Resecure the Boot Bolt and Spring underneath the Boot with an Allen key.
18. Tighten the Boot's set screw with an Allen key.
19. Reinsert the Boot Timing Bar's end in the Boot.
20. Tighten the Boot Timing Bar's nut and bolt.
21. Reattach the Ejection Tray with an Allen key.
22. Reinsert the Hopper.

Cleaning

During the TDP 0[®]'s operation, excess powder will find its way into parts of the machine, particularly in the Base, Hopper, Boot, Base Plate, and Tooling. It is important to clean the TDP 0[®] thoroughly to prevent rusting and cross contamination.

LFA recommends that the machine be cleaned after each operation and that a cleaning schedule is maintained, which is found in this section.

Tools and Materials Needed

- Cleaning brush
- Long wire pipe cleaner
- Toothbrush
- Cleaner (such as heavy duty foam cleaner; NSF approved if food grade product)
- Set of metric Allen keys with ball ends
- 13 mm wrench
- 24 mm wrenches (2)
- Grippers or pliers (if parts are difficult to remove)
- Hammer (if Die is difficult to remove)
- Disposable latex/rubber gloves
- 3 clean cloths
- Bowl of warm soapy water (nothing abrasive)
- Hairnet and/or beard net (food grade products only)
- Sterile shoe covers (food grade products only)



CAUTION: Overtightening bolts and/or screws can damage TDP 0[®] parts.

Instructions

Note: Wear latex/rubber gloves (and appropriate food grade attire if applicable) during this process.

Remove Parts

1. Remove the Hopper carefully and catch any powder still inside it.



2. Remove excess powder and any tablets from the Ejection Tray with a cleaning brush.
3. Remove the Ejection Tray with an Allen key.

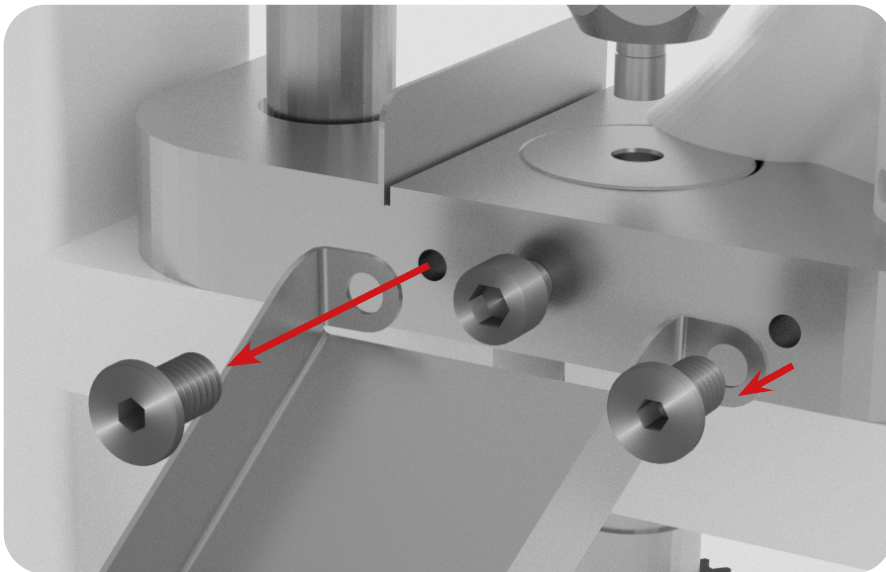

4. Loosen the Boot's set screw with an Allen key.

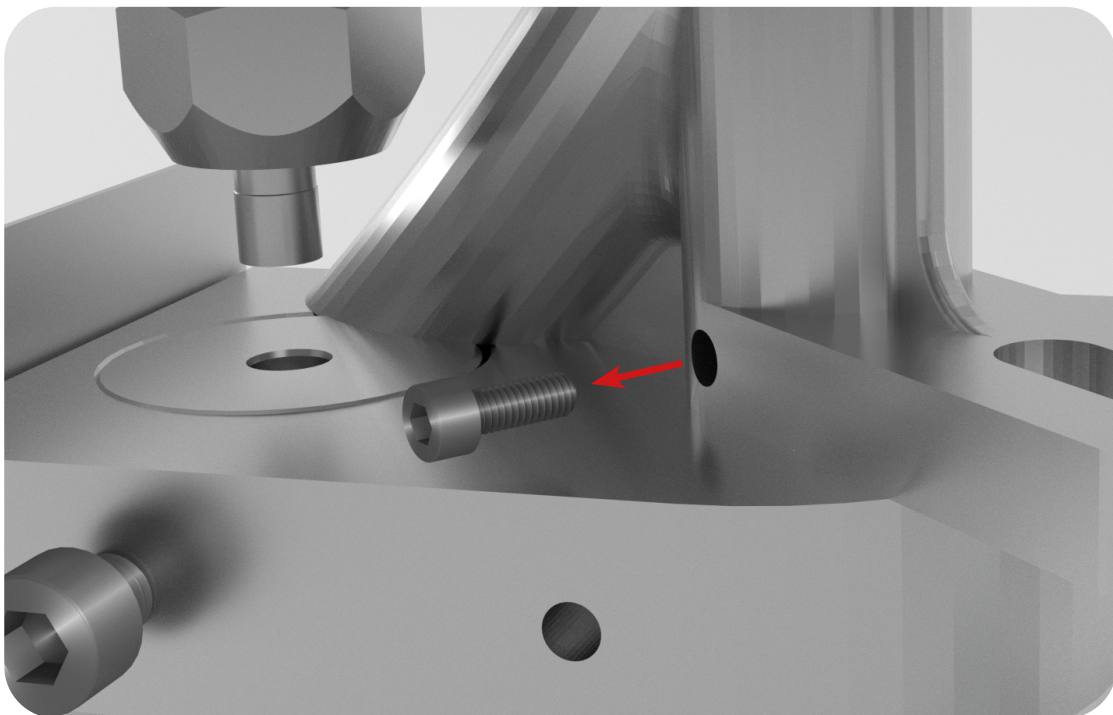

5. Remove the Boot Bolt and Spring underneath the Boot with an Allen key.

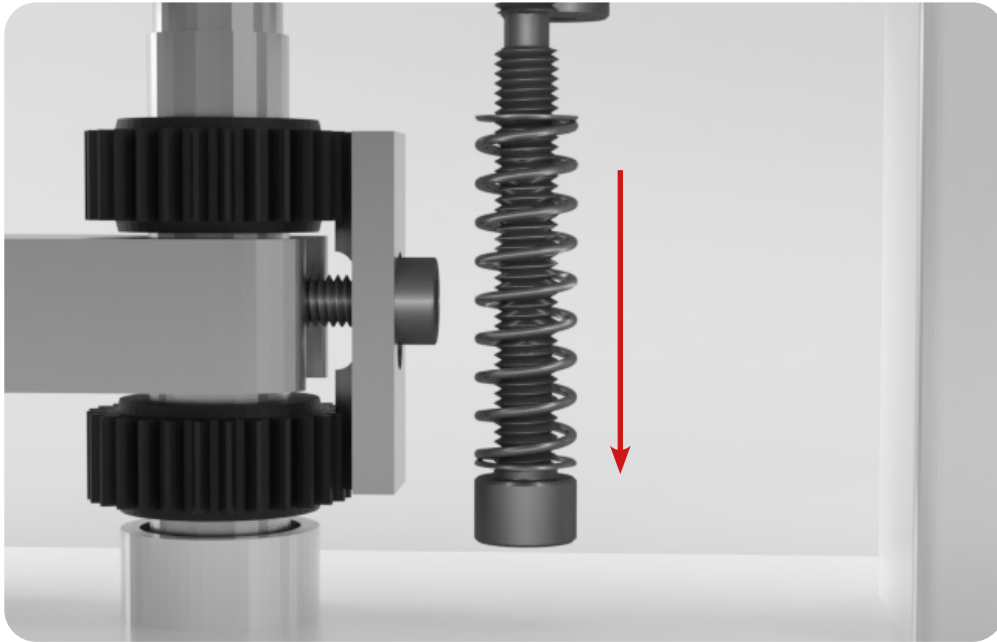

- 6. Remove the Boot carefully and remove any powder still inside it.
- 7. Loosen the bolts underneath the Base Plate with an Allen key.

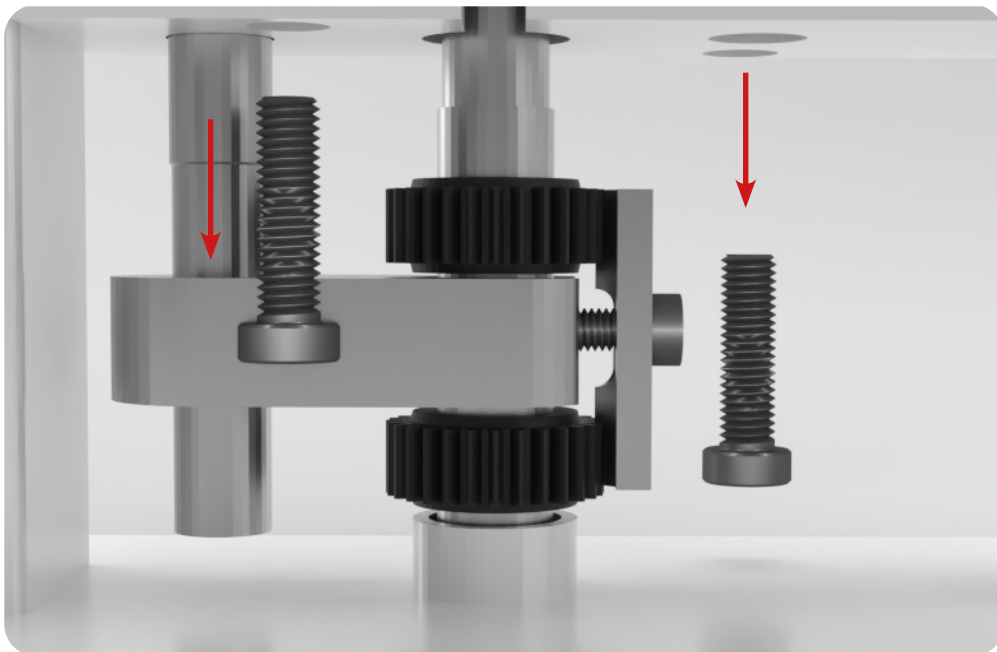

8. Turn the Handle until the Upper Drift Pin Assembly is lowered.
9. Loosen the Upper Punch Locking Nut with a wrench while keeping the Upper Punch Drift Assembly in place with another wrench.
10. Remove the Upper Punch by hand.

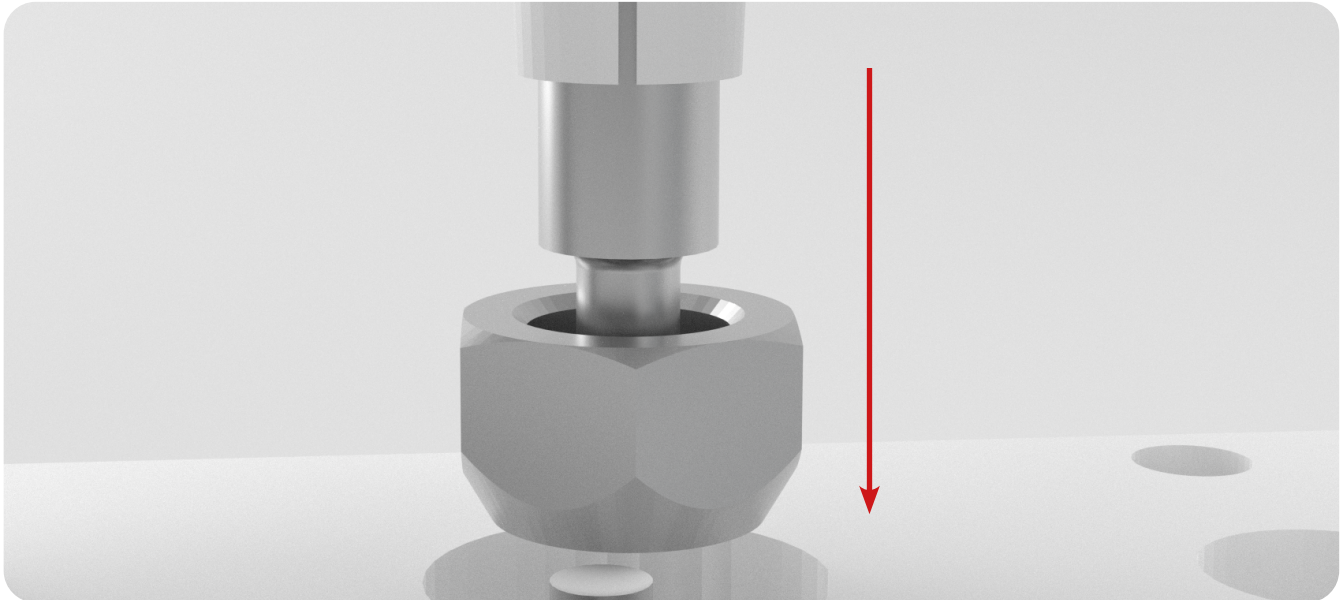

10.1 Note: If you cannot remove by hand, carefully use grippers or pliers.

11. Remove the Base Plate with the Die still inside it.
12. Remove the bolt that locks the Die with an Allen key.
13. Take out the Die from the middle of the Base Plate.

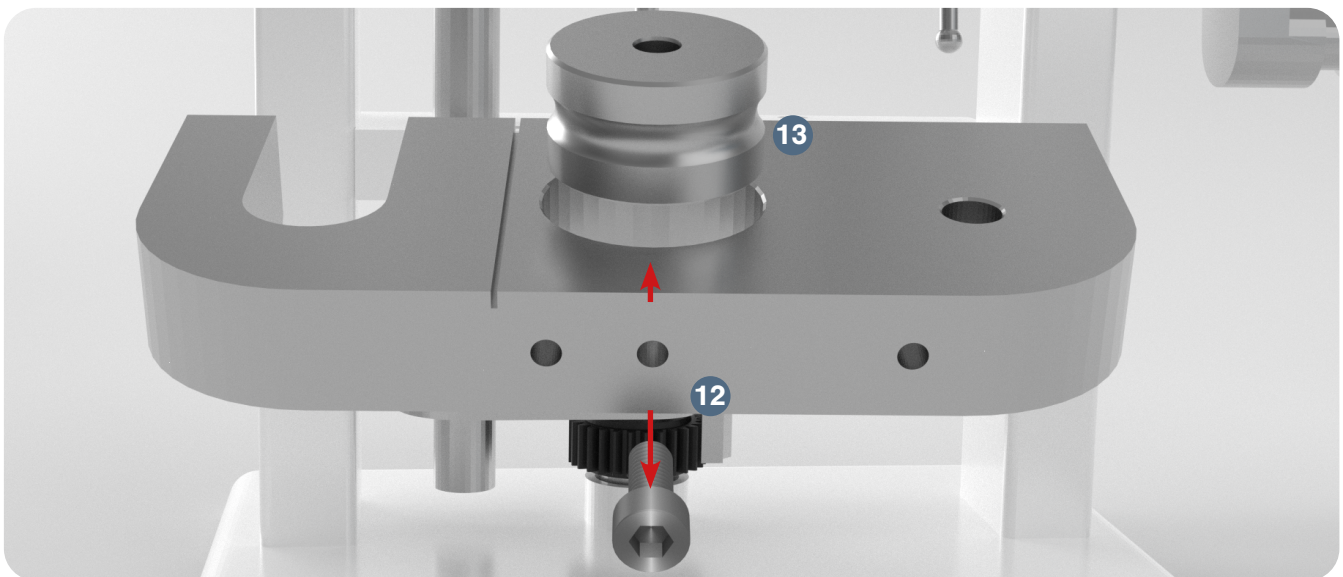

13.1 Note: Lightly tap the Die with a hammer if it is difficult to remove.

14. Remove the bolt that locks the Lower Punch with an Allen key.
15. Remove the Lower Punch by hand.

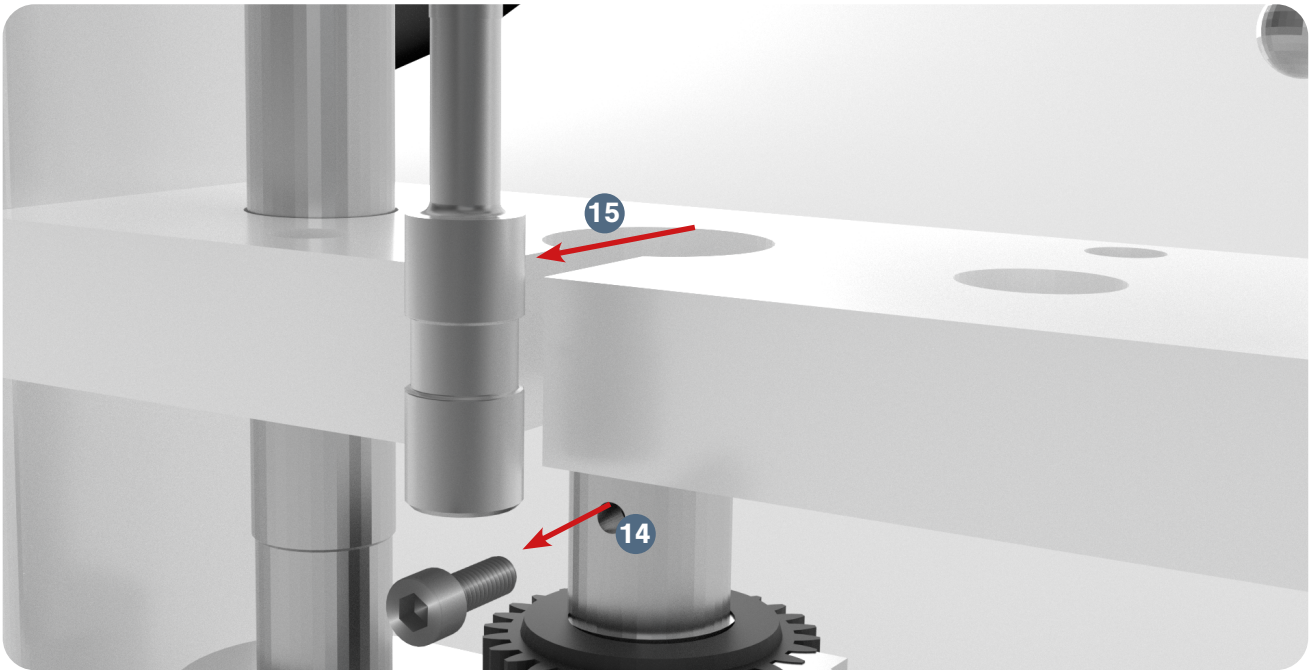

15.1 Note: If you cannot remove by hand, carefully use grippers or pliers.

Clean the Base

16. Spray the TDP 0[®] Base with the cleaner, particularly in the Tooling's location.

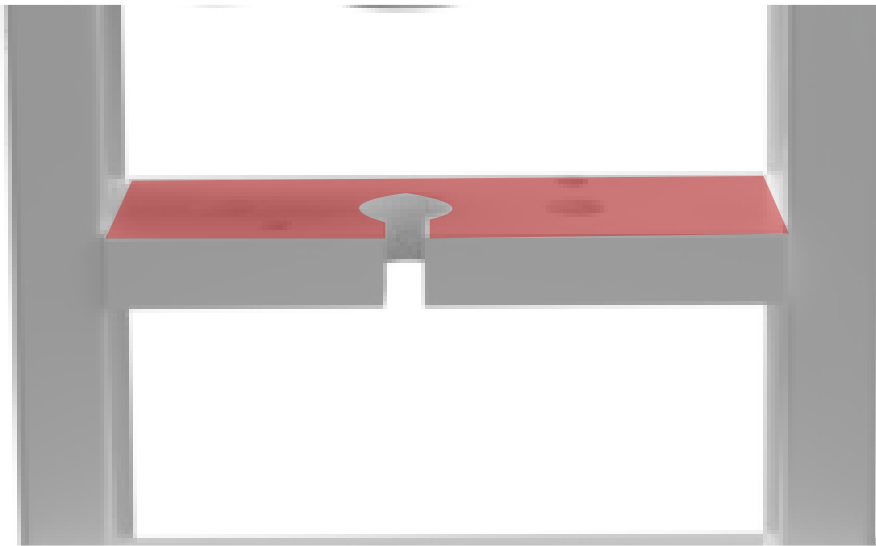

17. Wipe the cleaner off with a clean cloth, ensuring that all dirt and debris are gone.

Note: Before washing the Base Plate, LFA recommends using our Die Seat Cleaner. You can order the Die Seat Cleaner and Insertion Ring on our website at <https://www.lfatabletpresses.com/die-seat-cleaner-insertion-ring>



Clean the Parts

18. Take one of the parts removed from the machine and submerge it in the bowl of warm soapy water.

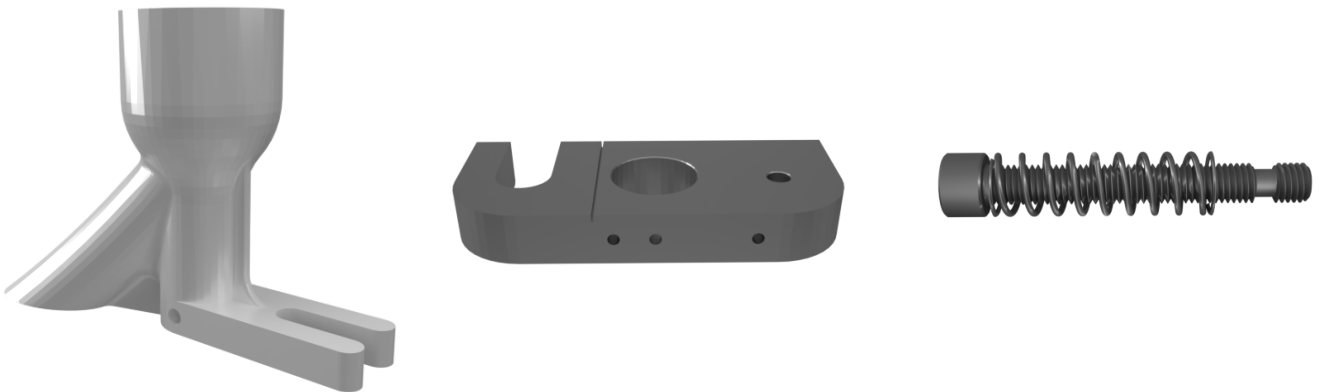

18.1 Note: To ensure that all dirt and debris are removed, wash one part at a time.

19. Take a clean cloth and carefully wash the part thoroughly.

20.1 Note: Use the toothbrush for difficult-to-remove debris. When cleaning tooling, use non-abrasive cleaning equipment such as a soft pipe cleaner and soft cloth.

20. Dry part immediately after it is cleaned and rinsed.

21. Repeat steps 18-20 for each remaining part until they are all clean.

Reassemble the Parts

22. Insert the Lower Punch back into the Lower Drift Pin Assembly.
23. Tighten the Lower Punch's bolt with an Allen key.

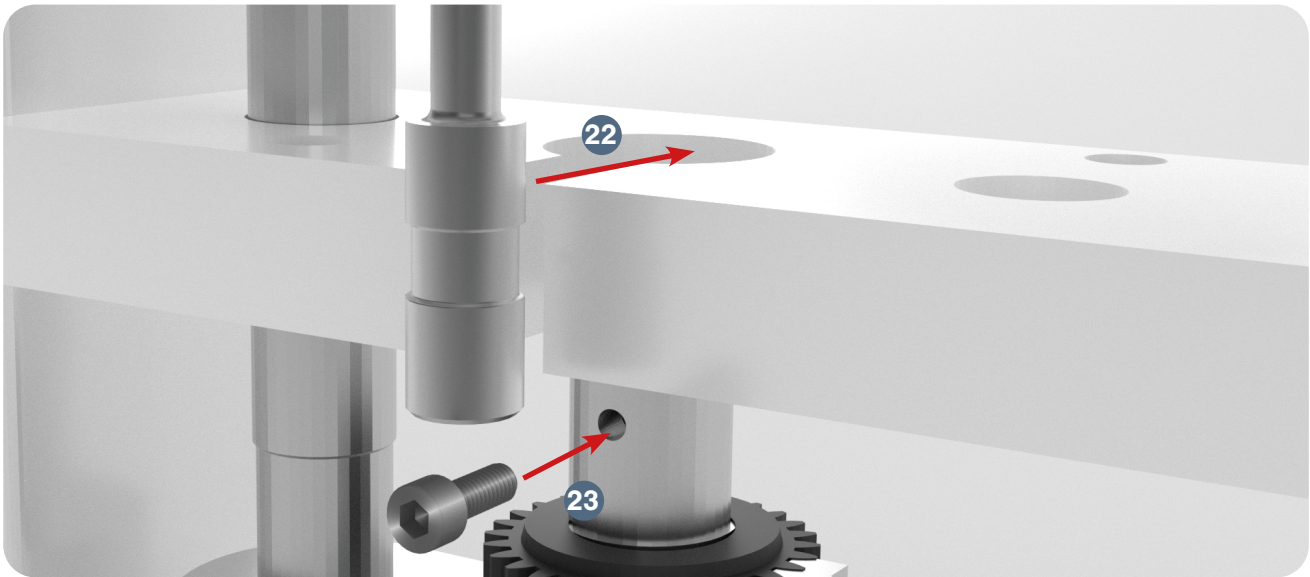

23.1 Note: Make sure that the “keyed” section is facing forward.

24. Insert the Die into the middle of the Base Plate.
25. Tighten the Die's set screw with an Allen key.

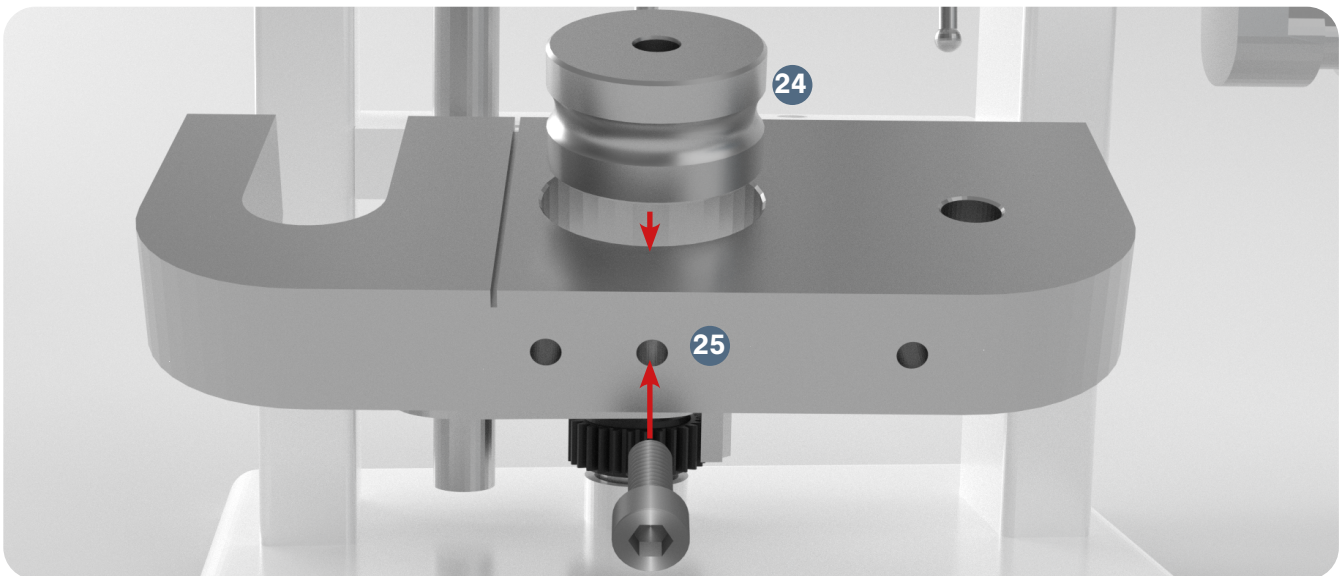

26. Turn the Handle until the Upper Drift Pin Assembly is lowered.
27. Insert the Upper Punch into the Upper Drift Pin Assembly.
28. Tighten the Upper Punch Locking Nut onto the Upper Drift Pin Assembly with a wrench.

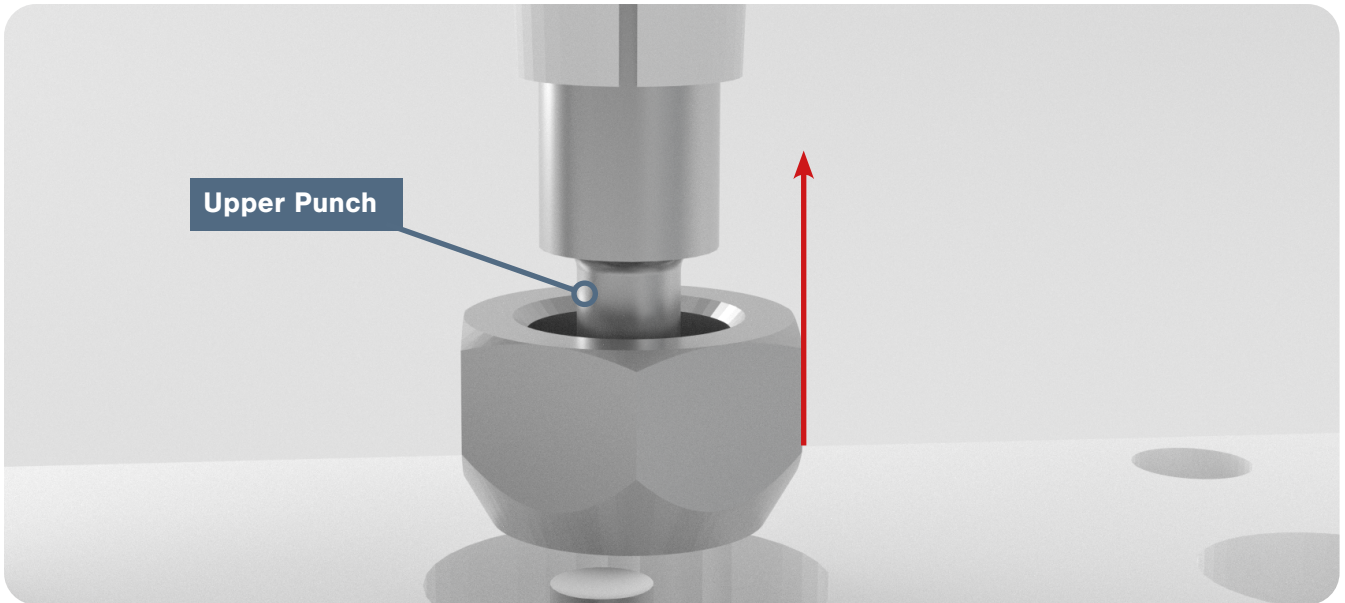

28.1 Note: Rotate the Handle to see that the Upper Punch smoothly enters the Die bore.

29. Reattach the Base Plate bolts to the Base with an Allen key.

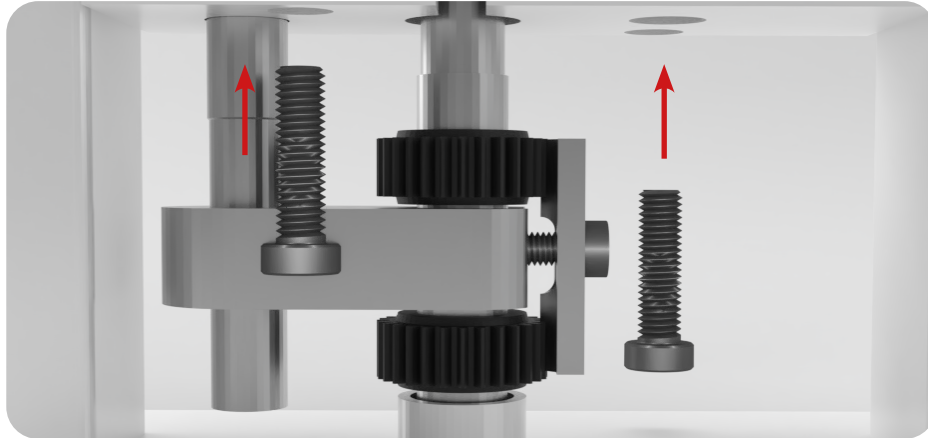

30. Position the Boot back on the Base Plate.
31. Insert the Boot Timing Bar's end in the Boot
32. Resecure the Boot Bolt and Spring underneath the Boot with an Allen key.
33. Tighten the Boot's set screw with an Allen key.

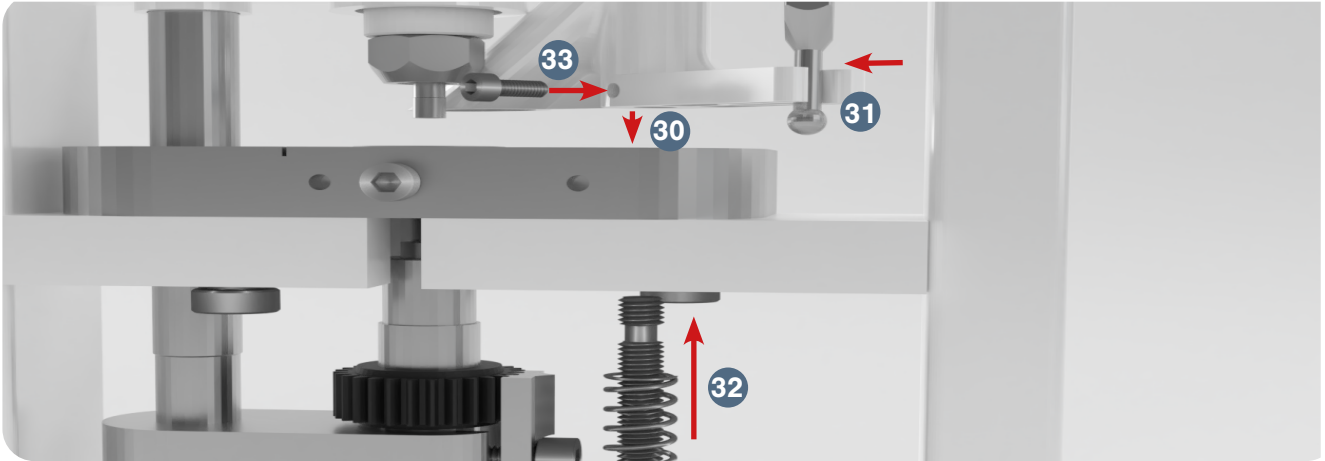

34. Reattach the Ejection Tray with an Allen key.
35. Reinsert the Hopper.

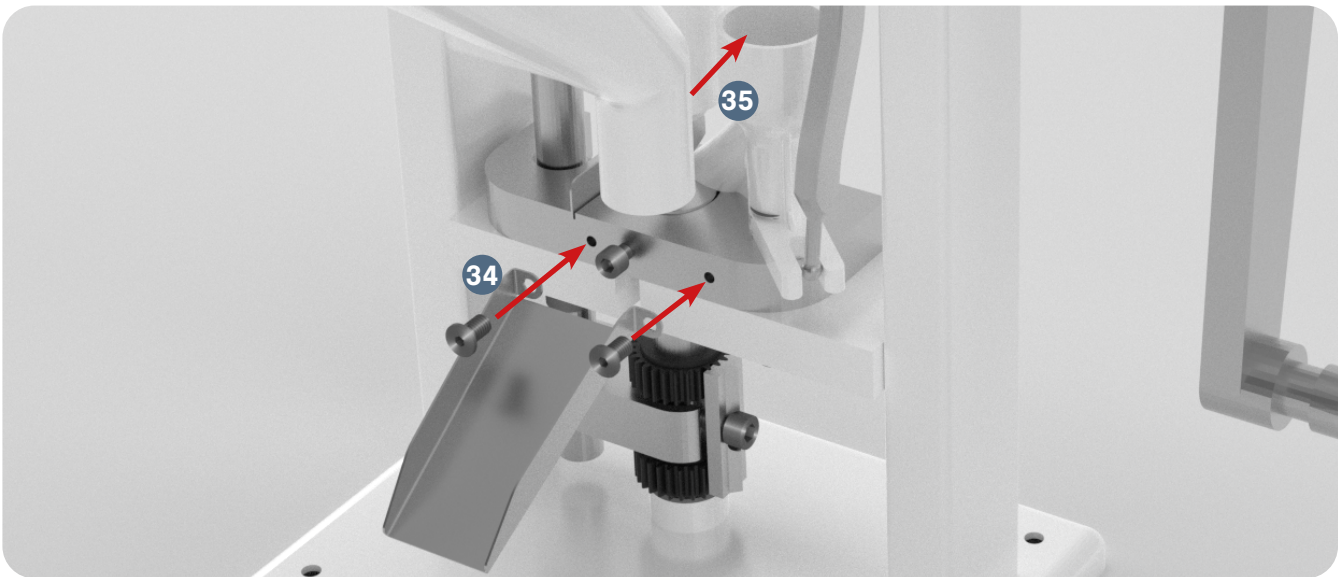

Cleaning Schedule Matrix

Part	Frequency							
	After installing machine	After every use	Before every use	In between products that present a cross contamination risk	Weekly	Monthly	Before placing in storage	After removing from storage
Ejection Tray	Remove from machine	Remove from machine	Install on machine	Remove from machine	N/A	N/A	Remove from machine	Install on machine
Tooling	Remove from machine	Remove from machine	Install on machine	Remove from machine	N/A	N/A	Remove from machine	Install on machine
Boot	Remove from machine	Remove from machine	Install on machine	Remove from machine	N/A	N/A	Remove from machine	Install on machine
Base Plate	Remove from machine	Remove from machine	Install on machine	Remove from machine	N/A	N/A	Remove from machine	Install on machine
Hopper	Remove from machine	Remove from machine	Install on machine	Remove from machine	N/A	N/A	Remove from machine	Install on machine
Top Cam area	Clean in machine	Clean in machine	Clean in machine	Clean in machine	Clean in machine	Clean in machine	Clean in machine	Clean in machine
Upper Drift Pin Assembly	Remove from machine	Remove from machine	Remove from machine	Remove from machine	Remove from machine	Remove from machine	Remove from machine	Remove from machine
Upper Drift Pin Assembly Threaded Cam	Clean in machine	Clean in machine	Clean in machine	Clean in machine	Clean in machine	Clean in machine	Clean in machine	Clean in machine
Lower Drift Pin Assembly	Remove from machine	Remove from machine	Remove from machine	Remove from machine	Remove from machine	Remove from machine	Remove from machine	Remove from machine
Exterior	Clean on machine	Clean on machine	Clean on machine	Clean on machine	Clean on machine	Remove from machine	Clean on machine	Clean on machine

Cleaning Level Key

Level 1 - Remove powder
Level 2 - Dry clean with cloth
Level 3 - Dry clean and re-lubricate if specified in lubrication schedule
Level 4 - Wet clean and re-lubricate if specified in lubrication schedule
Remove from machine - Take part out of machine and clean if required. Store it correctly or install back into machine.
Install into machine - Install part into the machine and make sure that it has been cleaned. If needed, lubricate to the level required.
Clean on/in machine - Clean the part while in the machine and do not remove it. Make sure that all contact surfaces are clean to the level required.

This cleaning matrix is intended as a guide only and is not an exhaustive list. All cleaning schedules will need to be adapted to the industry and product, following industry regulations and the material safety data sheets that come with specific products. Please check with your Food Safety Manager/Department, Quality Control Manager/Department, or other relevant internal departments at your company before using.

Storing and Transporting the TDP 0®

After its thorough cleaning, the TDP 0 needs to be stored in the proper conditions. It is important to store it in an environment in which the machine is safe from rusting. The TDP 0's high traction areas and the Tooling need to be lubricated separately before you store them.

Tools and Materials Needed

- Set of metric Allen keys with ball ends
- 24 mm wrenches (2)
- Grippers or pliers (if parts are difficult to remove)
- Hammer (if Die is difficult to remove)
- Plastic wrapping to cover machine
- Airtight container for Tooling (if in storage for more than a week)
- Grease gun
- Lubricant/grease (food grade lubricant if machine has a high chance of contact with the food or drug product)
- Disposable latex/rubber gloves (for food grade products and to protect hands from lubricant)
- Hairnet and/or beard net (food grade products only)
- Sterile shoe covers (food grade products only)



CAUTION: Overtightening bolts and/or screws can damage TDP 0® parts.

Instructions

Note: Wear latex/rubber gloves (and appropriate food grade attire if applicable) during this process.

Remove Tooling

1. Remove the Hopper carefully and catch any powder still inside of it.



2. Remove the Ejection Tray with an Allen key.

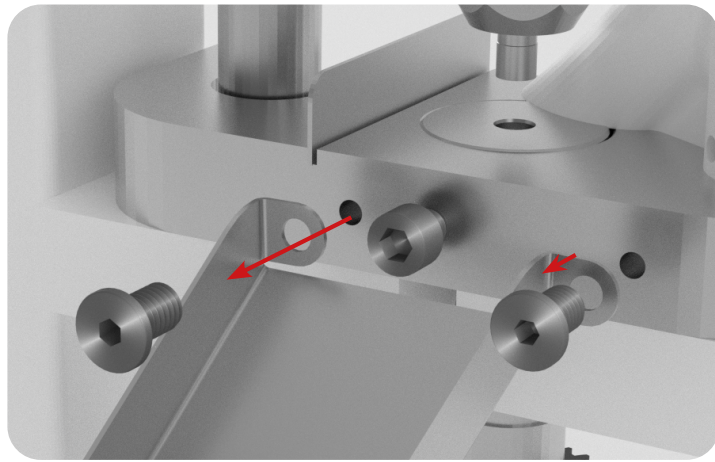

3. Loosen the Boot's set screw with an Allen key.

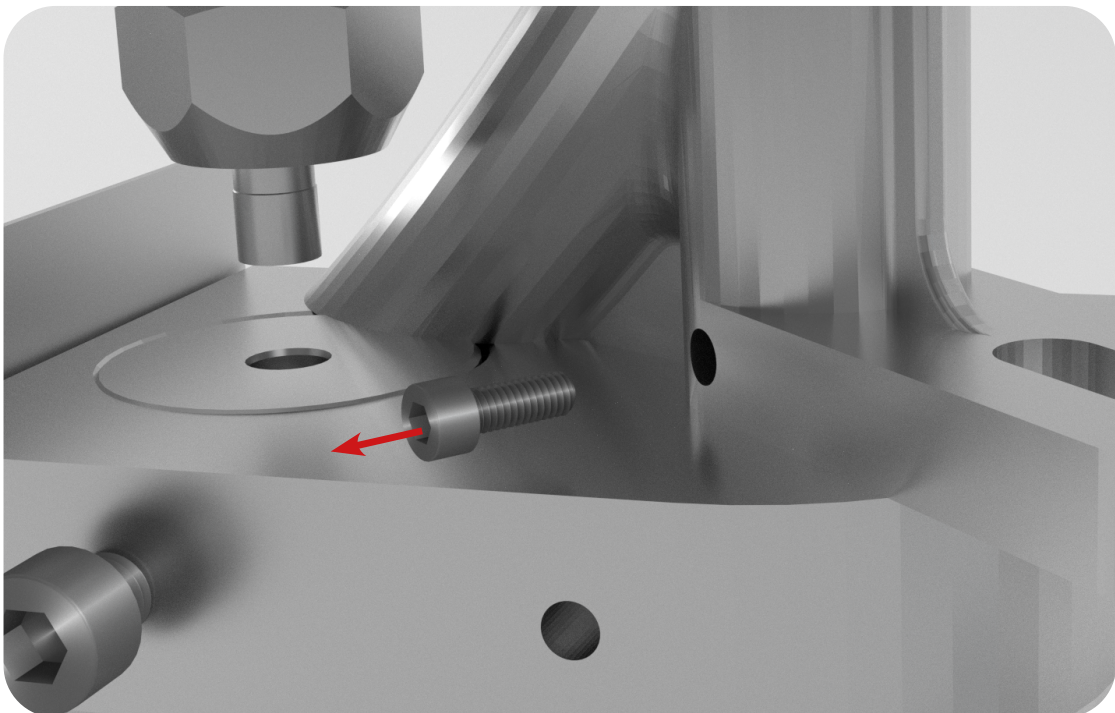

4. Remove the Boot Bolt and Spring underneath the Boot with an Allen key.

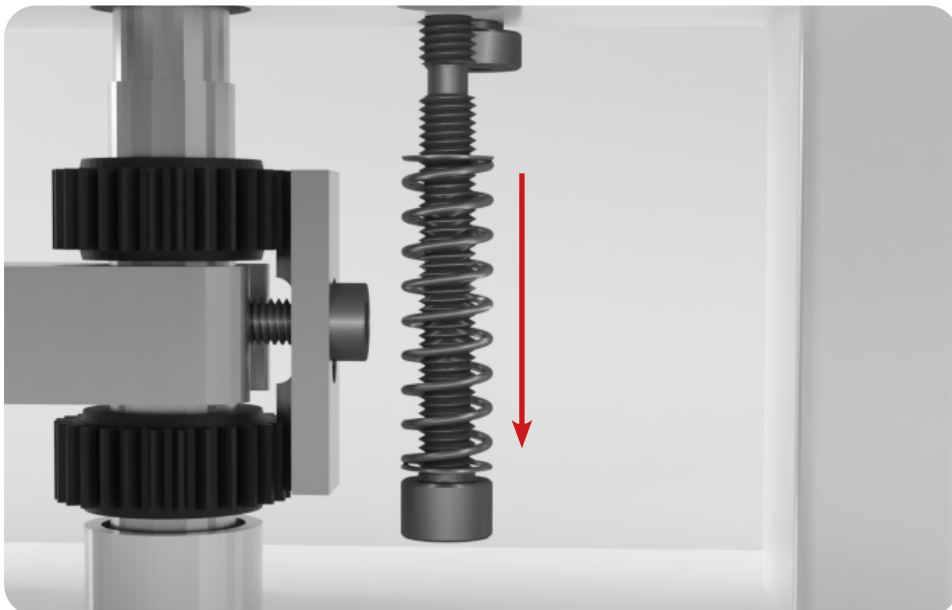

5. Take off the Boot carefully and remove any powder still inside it.
6. Loosen the bolts underneath the Base Plate with an Allen key.

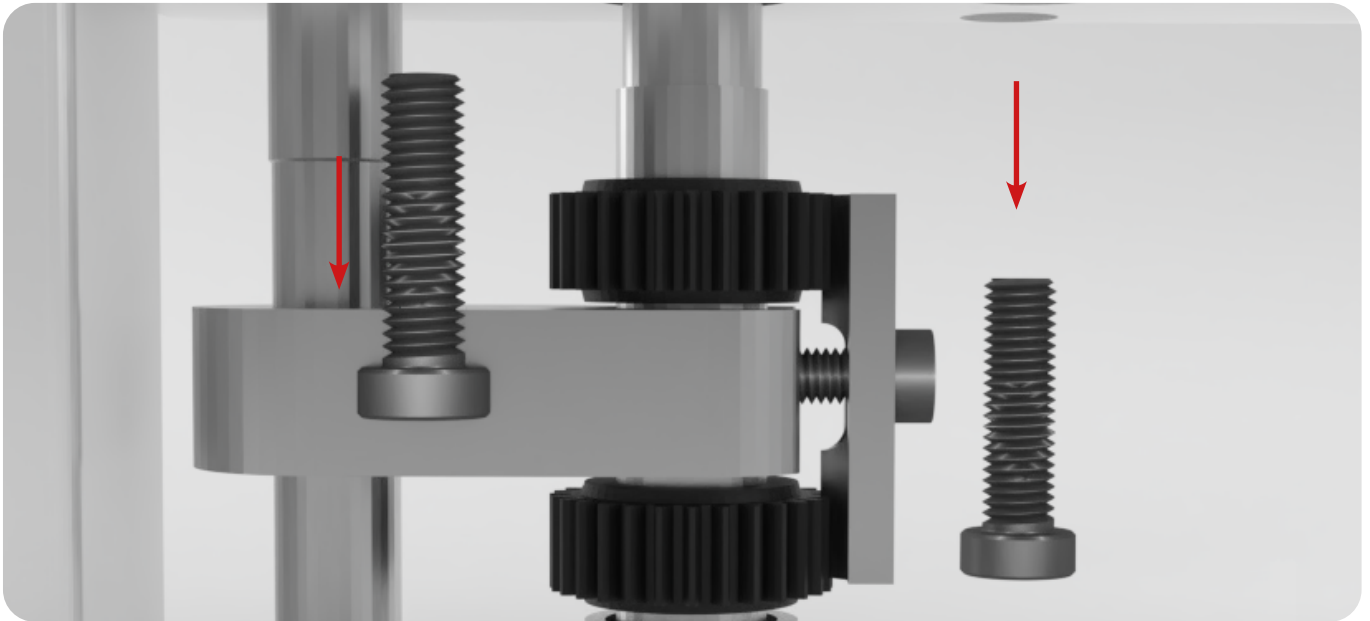

7. Turn the Handle until the Upper Drift Pin Assembly is lowered.
8. Loosen the Upper Punch Locking Nut with a wrench while keeping the Upper Punch Drift Assembly in place with another wrench.
9. Remove the Upper Punch by hand.

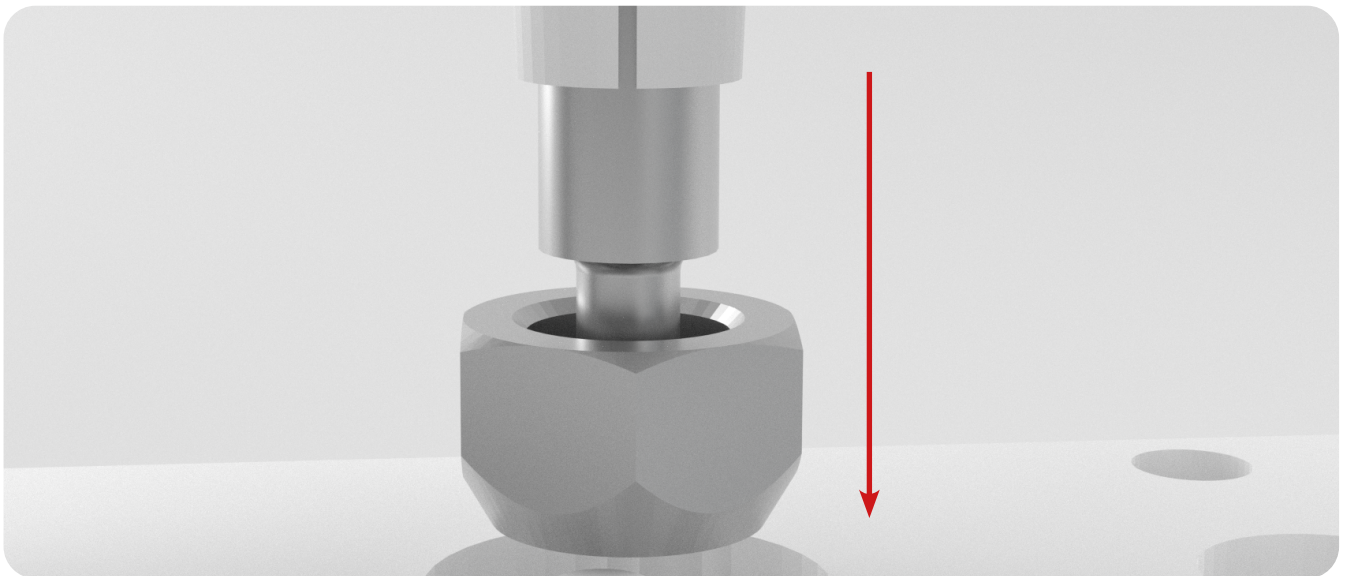

9.1 Note: If you cannot remove by hand, carefully use grippers or pliers.

10. Remove the Base Plate with the Die still inside it.
11. Remove the bolt that locks the Die with an Allen key.
12. Take out the Die from the middle of the Base Plate.

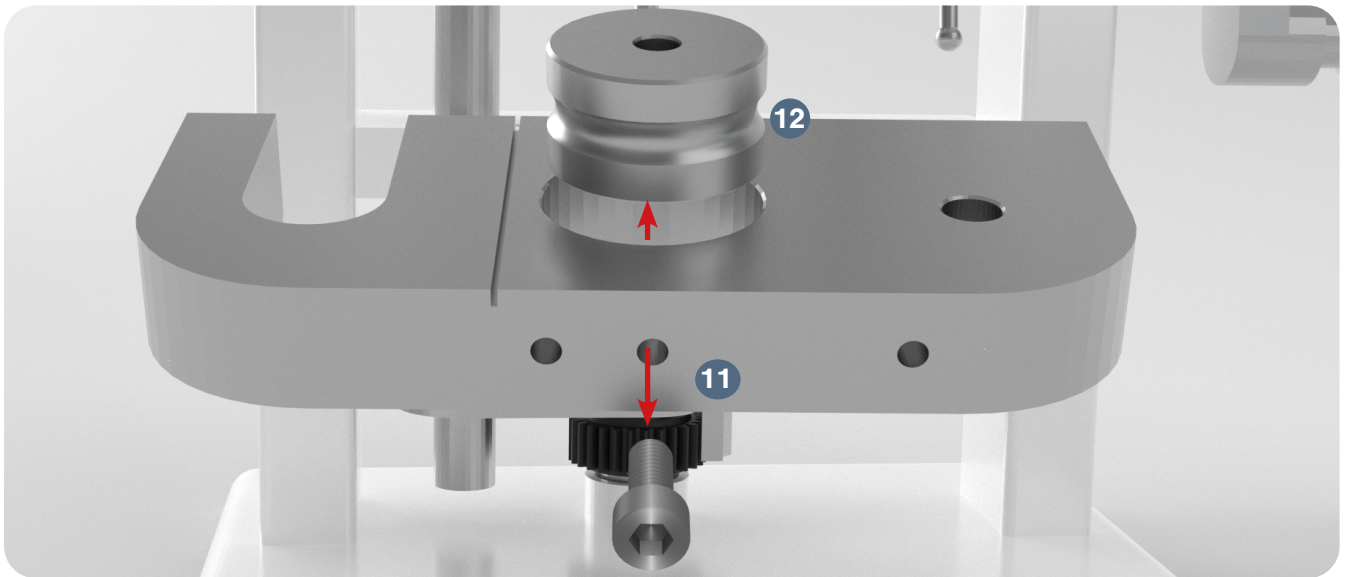

12.1 Note: Lightly tap the Die with a hammer if it is difficult to remove.

13. Remove the bolt that locks the Lower Punch with an Allen key.
14. Remove the Lower Punch by hand.

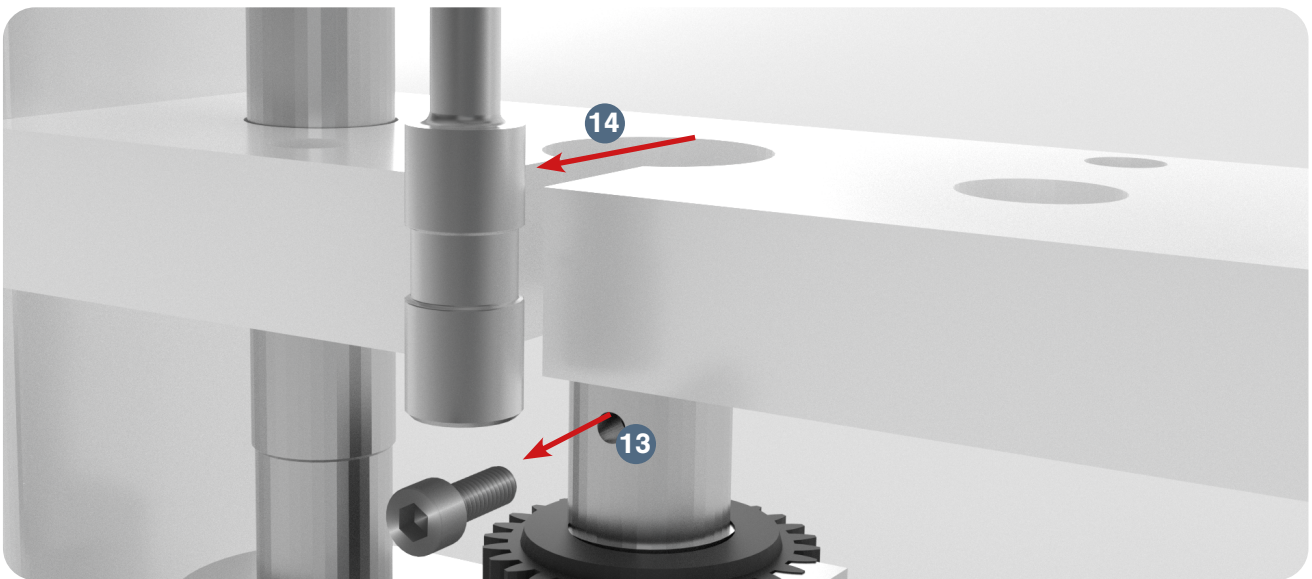

14.1 Note: If you cannot remove by hand, carefully use grippers or pliers.

Lubricating the Tooling

If you are not using the machine for more than a week, store the Tooling in an airtight container and cover it with lubricant to prevent rust formation. If not, simply lubricate each part of the Tooling and reinsert it back into the machine.



LFA's TDP Tooling Case provides airtight storage and is perfect for transport and protection. Order at <https://www.lfatabletpresses.com/tooling-case-tdp>

Lubricate High-Traction Areas

15. Rub a finger's worth of grease on the Boot Cam's side.
 - 15.1 Note: Be sure to grease around the Boot Timing Cam Runner.
16. Lubricate the Grease Nipple on top of the Eccentric Sheave Strap with the grease gun.
 - 16.1 Note: Rotate the Handle during this to ensure grease gets in between the Eccentric Sheave and the Eccentric Sheave Strap.
17. Lubricate the Lower Drift Pin Assembly Timing Cam.

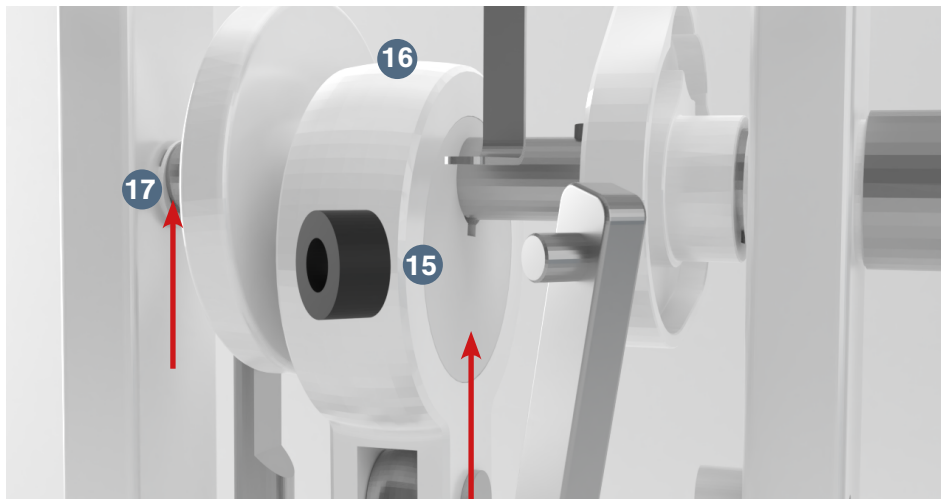

You can also lubricate any point of traction on the TDP 0[®] at your own discretion; just be sure not to over-lubricate.

Cover the TDP 0[®]

18. Carefully cover the TDP 0[®] with the plastic wrapping.
 - 18.1 Note: You can use the plastic wrapping that came with the machine in the shipping container.

Environmental Conditions

It is important that the environment in which you store the TDP 0[®] has the appropriate temperature and relative humidity levels. These two environmental factors can potentially cause the machine to rust and/or cause the tablets to have a lower quality. The table below shows the acceptable temperature and relative humidity levels:

Machine	Temperature		Humidity
	°C	°F	
TDP 0 [®]	18-24	64-75	45-65% RH

TDP 0[®] Transport



WARNING: To prevent personal injury, wear steel toe boots and heavy duty grip gloves while transporting the TDP 0[®].

The TDP 0[®] weighs around 21 kg (48 lbs), so it is possible for it to be moved by one or two people. To safely transport the TDP 0[®], grab both its handle at the top and the bottom of the TDP 0[®] Base for support.

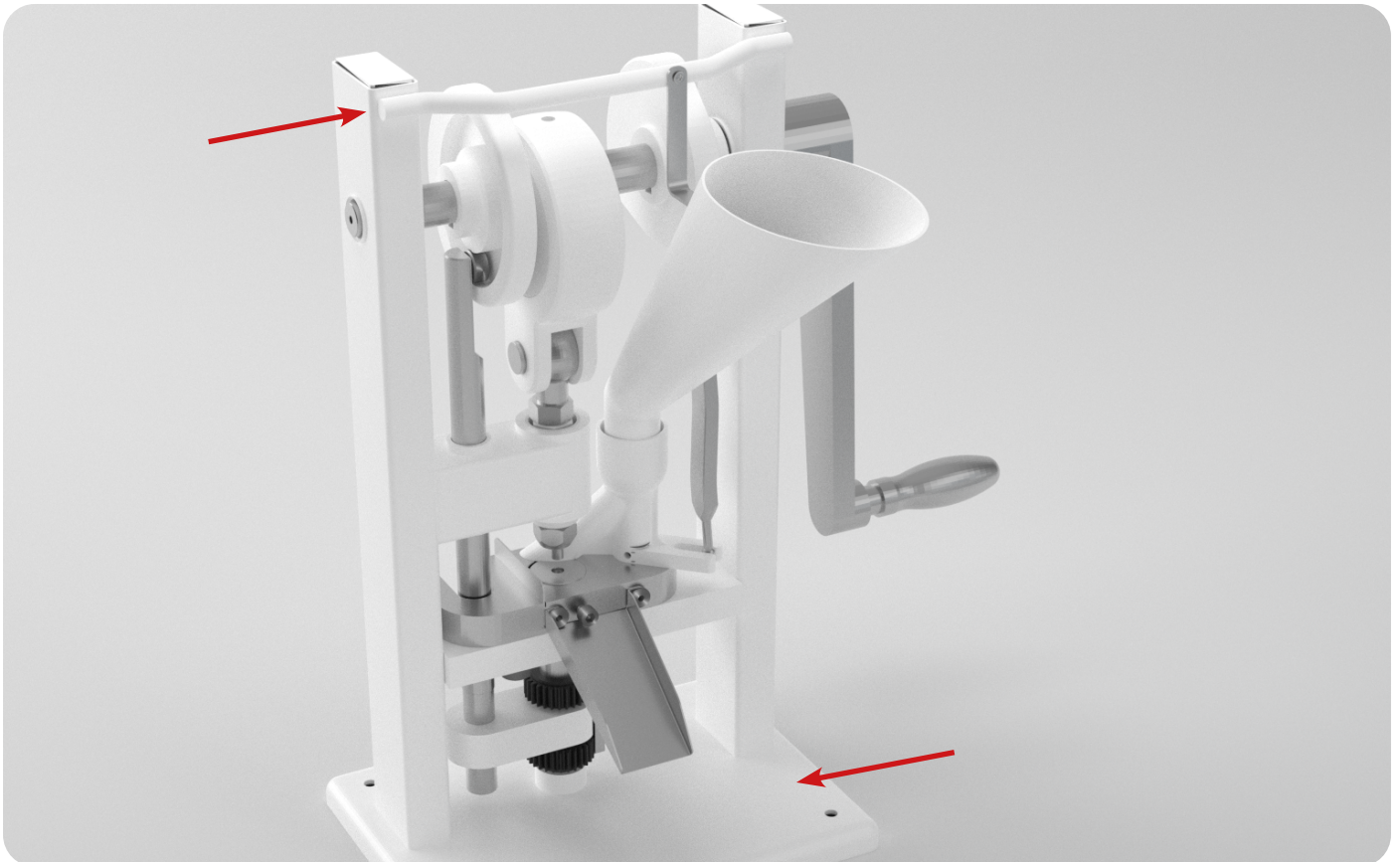

Appendix

Glossary

Term	Definition
API/Active Pharmaceutical Ingredient	Any substance or mixture of substances used that is an active ingredient in the drug product.
Binding agent	See excipient.
Die	The circular part of the Tooling in which the powder is compressed and shaped into a tablet.
Die bore	The cavity inside the middle of the Die.
Die face	The very top flat surface of the Die.
Ejection height	The height at which the Lower Punch is lifted to for a tablet's ejection from the machine.
Excipient	An inactive substance that serves as the vehicle or medium for a drug or other API.
Fill depth	The amount of space that the powder can flow into in the Die.
Formulation	Powder mix of the excipient and the API that is compressed to make tablets.
Granular material	See Formulation.
Kilonewton (kN)	The force to accelerate a mass of 1 kg at a constant 1 m per second. The TDP machine range's pressure is measured in this unit.
Punches	The Upper Punch and Lower Punch have concave endings in the shape of the desired tablet. When the punches meet, they compress the powder between.
Punch pressure	The adjustable amount of force that is used to press tablets.
TDP®	LFA-trademarked term for desktop tablet press.
Tooling	Enables a tablet press to form tablets. It consists of a Die, Upper Punch, and Lower Punch.

Description of TDP 0[®] Parts

TDP Base (#ACB0000)

The TDP Base is the main base for the TDP 0[®], and all working parts are connected to it. It is important that the TDP Base be fixed onto a stable and secure workbench.



Lower Drift Pin Assembly Locking Bar (#AEC0013)

The Lower Drift Pin Assembly Locking Bar holds the Lower Drift Pin Assembly Cogs in place. Order at <https://www.lfatabletpresses.com/tdp0-lower-drift-pin-locking-bar>

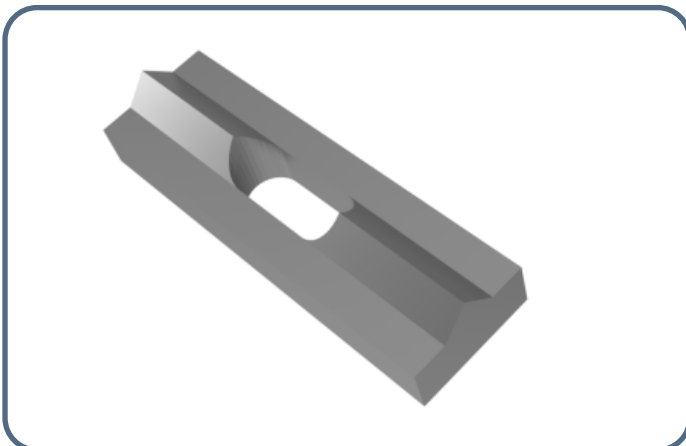

Tooling

The Tooling consists of the Die, the Upper Punch, and the Lower Punch. This die set compresses the powder into the tablet. Order at <https://www.lfatabletpresses.com/tdp-tooling>

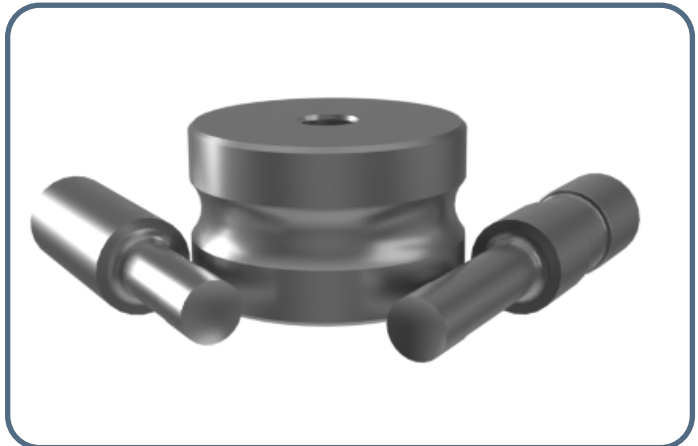

Lower Drift Pin Assembly Cogs (#AEC0012)

The Lower Drift Pin Assembly Cogs are used to adjust the tablet's fill depth and ejection height. They are located in the Lower Drift Pin Assembly. The Upper Cog adjusts the ejection height of the tablet. Turning it counterclockwise raises the ejection height, and turning it clockwise lowers it. The Lower Cog increases the tablet's fill depth (weight). Turning it clockwise increases the weight of the tablet, and turning it counterclockwise decreases the weight. Order at <https://www.lfatabletpresses.com/tdp0-lower-pin-cogs>



Boot (#AEC0036)

The Boot is where the dry granular materials are held for pressing. It fills the Die bore with the dry granular material and moves the finished tablet out of the Die before refilling it with the next batch of materials. Order at <https://www.lfatabletpresses.com/tdp0-boot>

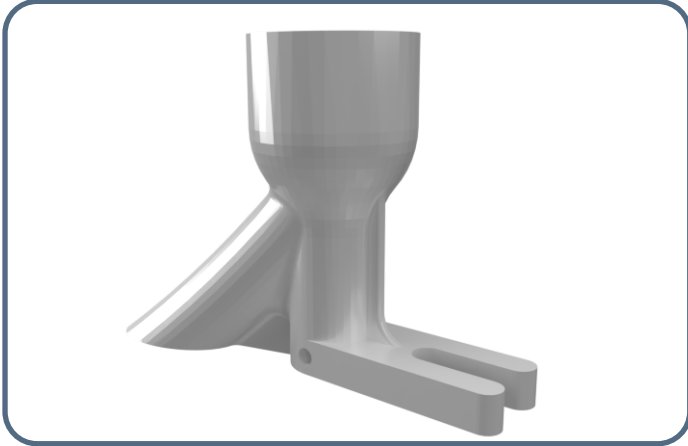

Arm (#ACC0010)

The Arm is used for turning the Top Cam Drive Shaft, which moves each part of the TDP 0[®]. Order at <https://www.lfatabletpresses.com/tdp0-arm>

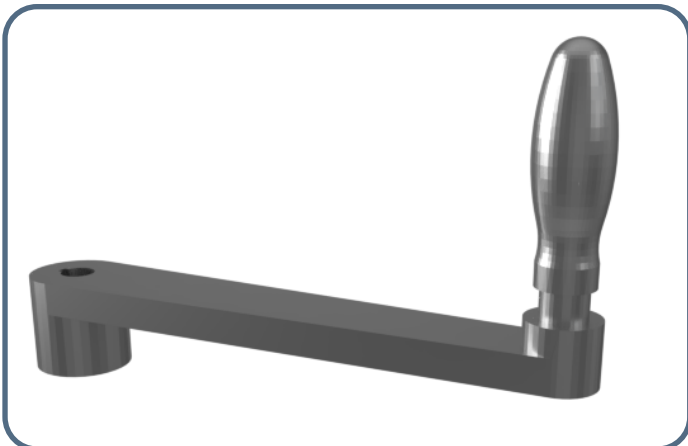

Hopper (#AEC0030)

The Hopper is the funnel that holds the granular materials before it moves into the Boot to be pressed. Order at <https://www.lfatabletpresses.com/tdp0-hopper-chute>

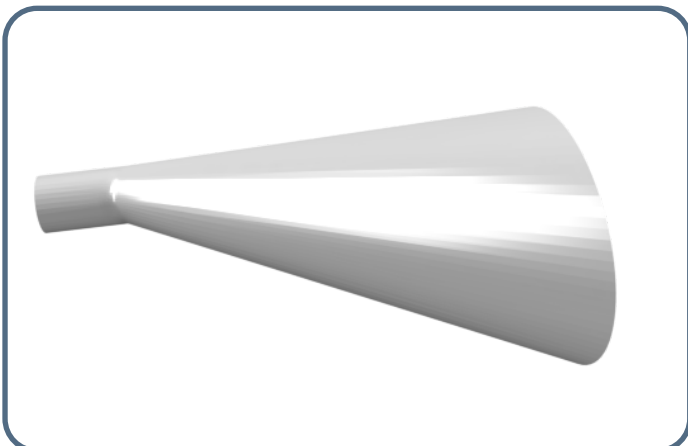

Boot Bolt and Spring (#AEC0051)

The Boot Bolt and Spring holds the Boot in place while the press is running and allows it to move back and forth. It is kept secure with the Locking Nut on the side of the Boot. Order at <https://www.lfatabletpresses.com/tdp0-boot-bolt-spring>

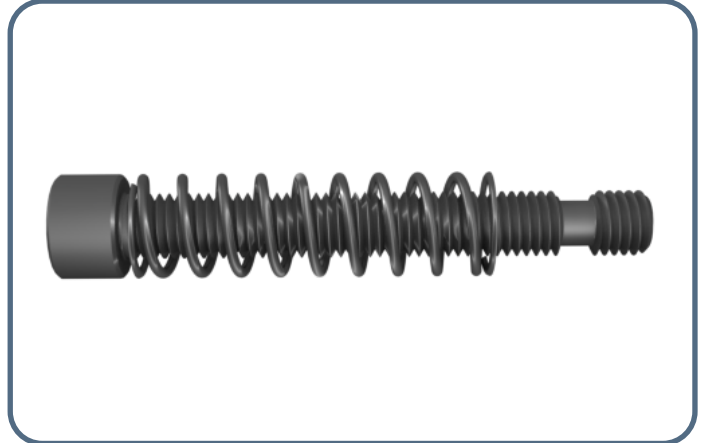

Eccentric Sheave Strap (#AEC0004)

The Eccentric Sheave Strap attaches the Upper Drift Pin Assembly to the Top Cam Drive Shaft. Order at <https://www.lfatabletpresses.com/tdp0-eccentric-sheave-strap>

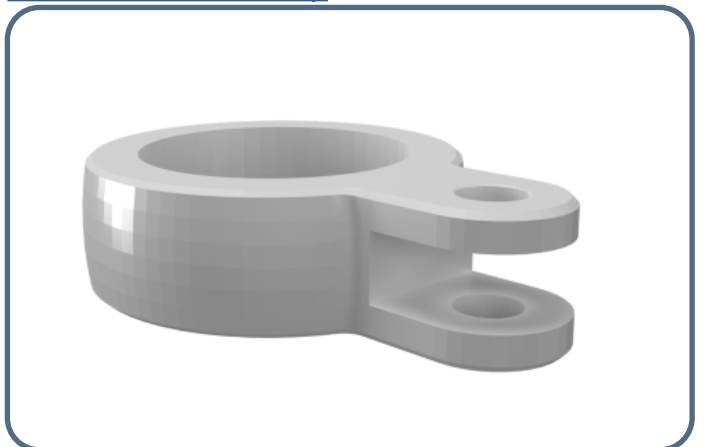

Upper Drift Pin Assembly Rod Eye and Clevis (#AEC0005)

The Upper Drift Pin Assembly Rod Eye and Clevis is the part that connects the Eccentric Sheave to the Upper Drift Pin Assembly, which holds the Upper Punch. Order at <https://www.lfatabletpresses.com/tdp0-upper-drift-threaded-cam>

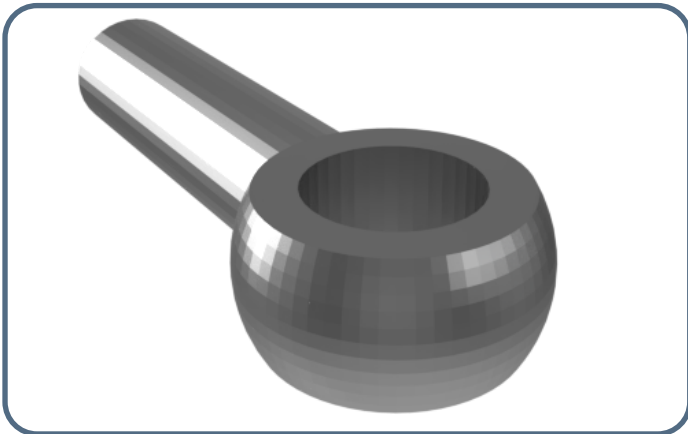

Top Cam Drive Shaft (#ACC0006)

All other TDP 0® parts are connected to the Top Cam Drive Shaft. As it is turned, all the parts of TDP 0® move. Order at <https://www.lfatabletpresses.com/tdp0-top-cam>

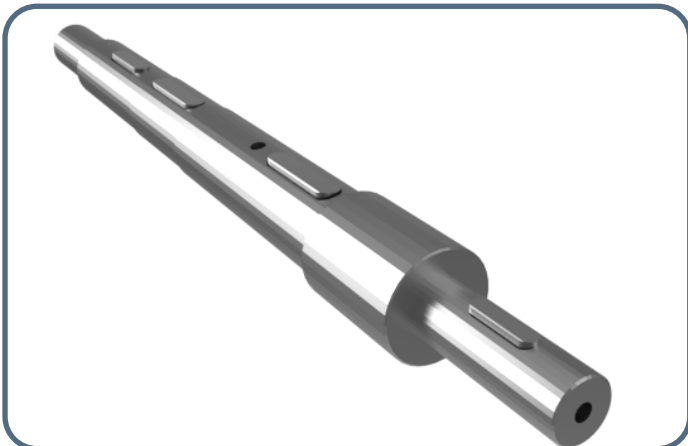

Grease Nipple (#H10C010201)

Grease Nipples are grease cap points that grease the TDP 0®'s gaps with high pressure. Order at <https://www.lfatabletpresses.com/tdp0-grease-nipple>



Boot Timing Cam (#ACC0004)

The Boot Timing Cam is responsible for the movement of the Boot Timing Bar, which allows the Boot to fill the Die bore with the dry granular materials needed to form the tablet. Order at <https://www.lfatabletpresses.com/tdp0-boot-timing-cam>

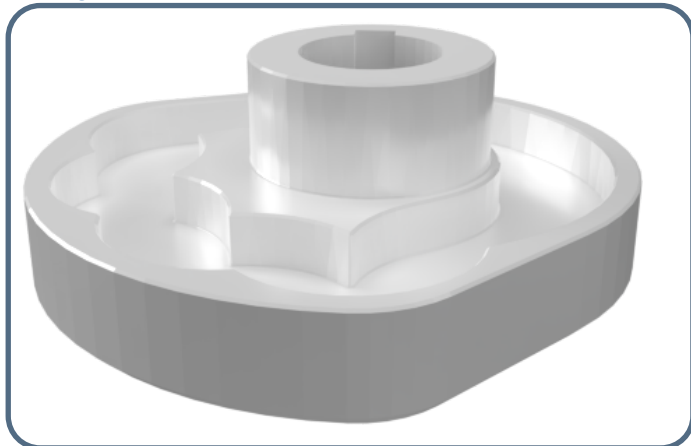

Eccentric Sheave (#ACC0005)

The Eccentric Sheave controls the timing of the Upper Drift Pin Assembly. Order at <https://www.lfatabletpresses.com/tdp0-eccentric-sheave>

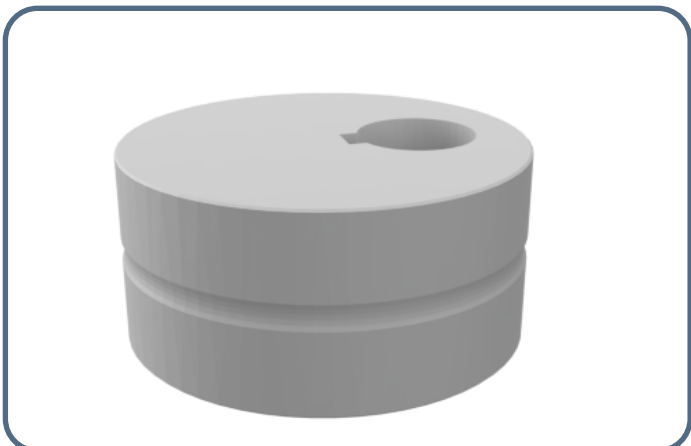

Lower Drift Pin Assembly Timing Rod (#ACC0002)

The Lower Drift Pin Assembly Timing Rod raises the finished tablet out of the Die. It works by riding the Upper Drift Pin Assembly Timing Cam. Order at <https://www.lfatabletpresses.com/tdp0-lower-assembly-timing-bar>

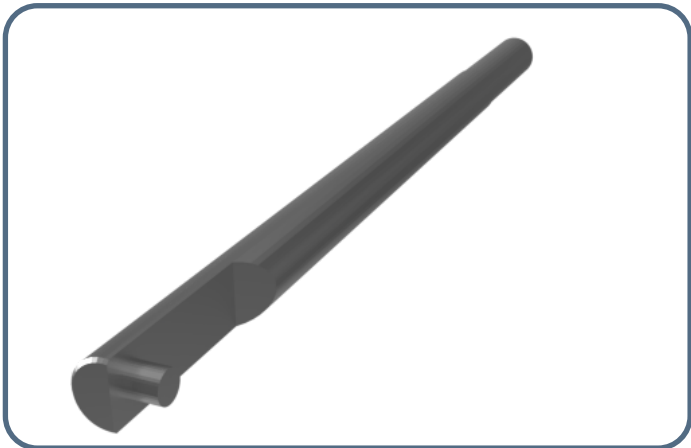

Lower Drift Pin Assembly (#AEC0011)

The Lower Drift Pin Assembly is located below the base of the tablet. It holds the Lower Punch in place in the Die while the Upper Punch pushes down to form the tablet in the middle. Order at <https://www.lfatabletpresses.com/tdp0-lower-drift-pin>

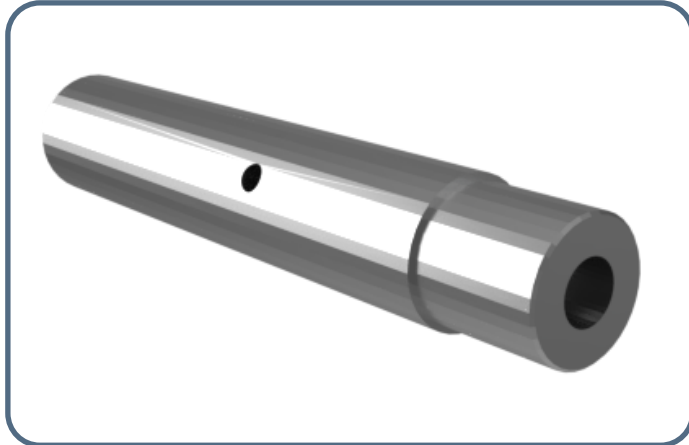

Upper Drift Pin Assembly Locking Nut (#AEC0006)

The Upper Drift Pin Locking Nut is a large nut used to secure the Upper Drift Pin Assembly in place. Order at <https://www.lfatabletpresses.com/tdp0-upper-drift-pin-locking-nut>



Boot Timing Drive Bar Runner (#AEC0020)

The Boot Timing Cam Runner is a round section that connects the Lower Assembly Timing Bar to the Top Cam Drive Shaft, which keeps the timing. Order at <https://www.lfatabletpresses.com/tdp0-boot-timing-runners>

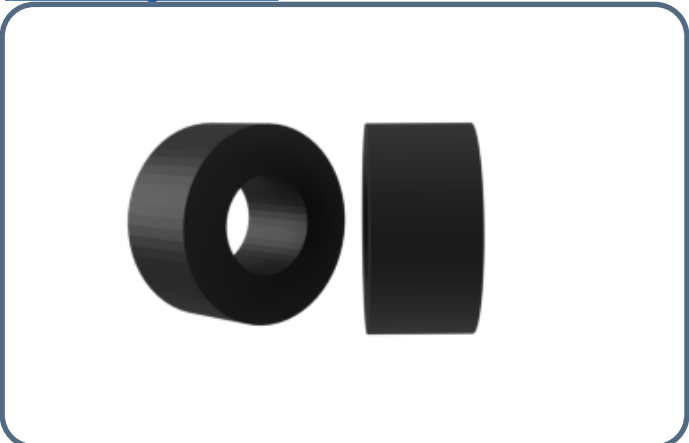

Upper Punch Locking Nut (#AEC0003)

The Upper Punch Locking Nut is a large nut used to secure the Upper Punch in place. Order at <https://www.lfatabletpresses.com/tdp0-upper-punch-die-pin-locking-nut>

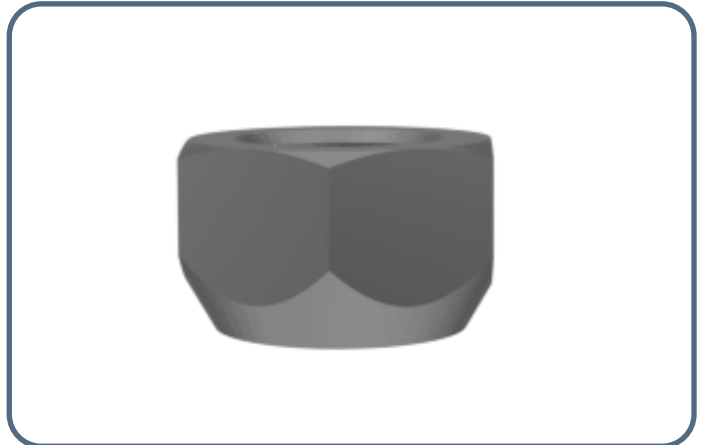

Eccentric Sheave Connecting Pin (#AEC0001)

The Eccentric Sheave Connecting Pin connects the Eccentric Sheave Strap and the Upper Drift Pin Assembly Rod Eye and Clevis. Order at <https://www.lfatabletpresses.com/tdp0-eccentric-sheave-connecting-pin>

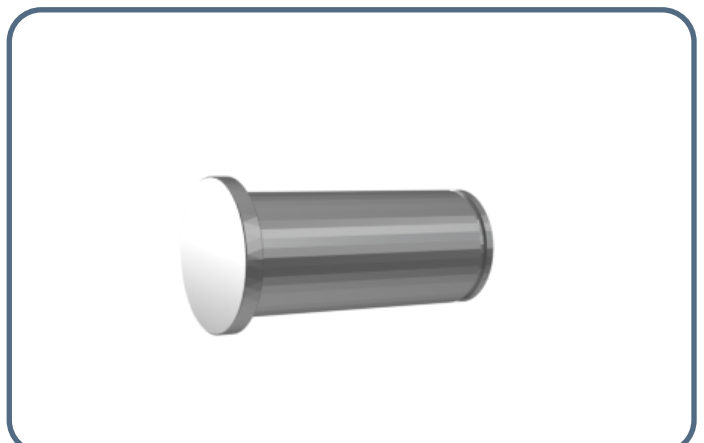

Boot Timing Bar Pin

The Boot Timing Bar Pin causes the Boot Timing Bar to pivot, allowing the Boot to move back and forth. Order at <https://www.lfatabletpresses.com/tdp0-boot-timing-bar-pin>



Handle (#ACC0010)

The Handle is a part of the Arm, which turns the Top Cam Drive Shaft that moves each part of the TDP 0®. Order at <https://www.lfatabletpresses.com/tdp0-handle>

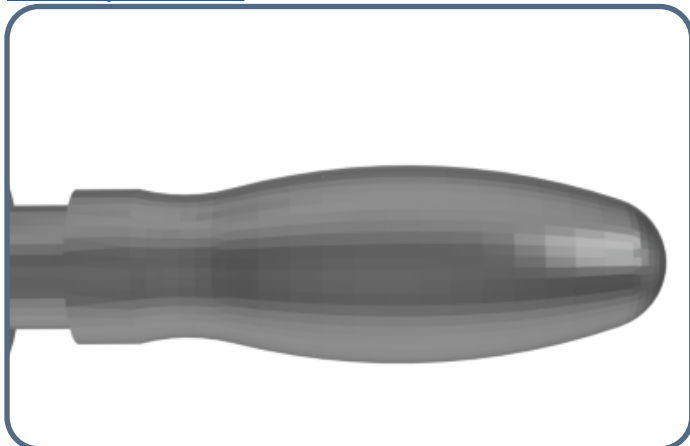

Boot Timing Bar (#AEC0018)

The Boot Timing Bar moves the Boot and is timed by the Boot Timing Cam track. The rocking motion that the arm provides helps the Boot to fill the Die bore with the dry granular material for the next tablet. Order at <https://www.lfatabletpresses.com/tdp0-boot-timing-bar>

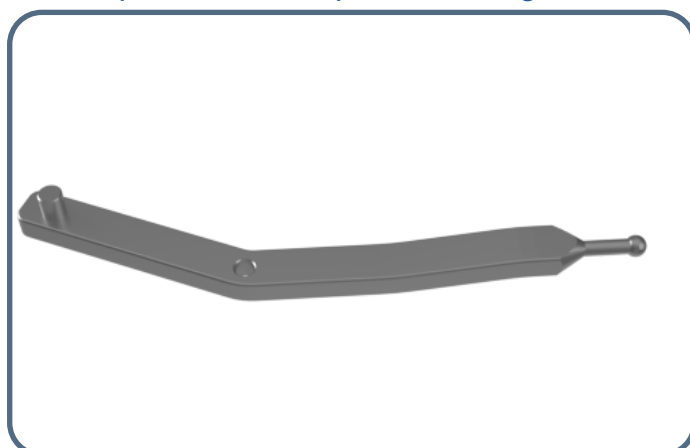

Upper Drift Pin Assembly (#AEC0002)

The Upper Drift Pin Assembly holds the Upper Punch in place and is attached to the Upper Drift Pin Assembly Rod Eye and Clevis. Order at <https://www.lfatabletpresses.com/tdp0-lower-pin-assembly>



Lower Drift Pin Assembly Lifting Bar (#AEC0034)

The Lower Drift Pin Assembly Lifting Bar lifts the Lower Drift Pin Assembly that holds the Lower Punch and helps push the tablets out of the Die. Order at <https://www.lfatabletpresses.com/tdp0-lower-drift-pin-lifting-bar>

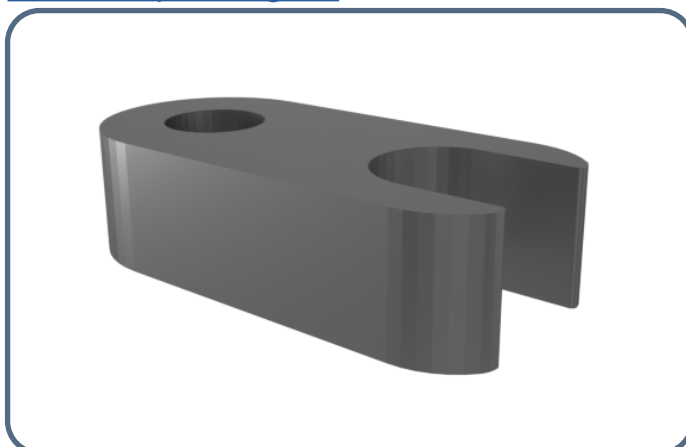

Base Plate (#AEC0008)

The Base Plate is not only the mount for the Boot, but also holds the Die in place. Order at <https://www.lfatabletpresses.com/tdp0-base-plate>

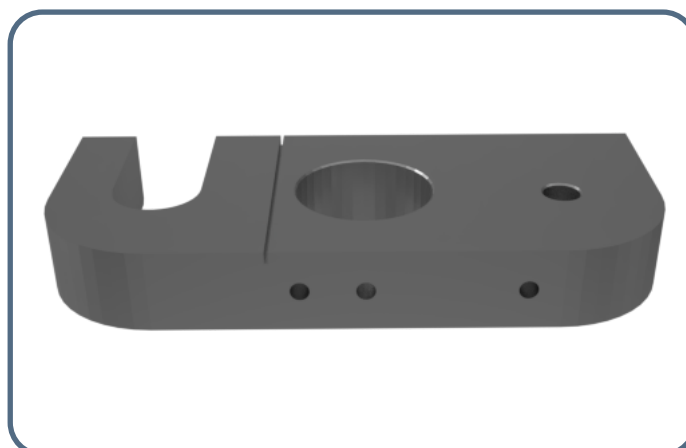

Lower Drift Pin Assembly Timing Cam (#ACC0001)

The Lower Drift Pin Assembly Timing Cam moves the Lower Drift Pin Assembly Timing Rod. Order at <https://www.lfatabletpresses.com/tdp-1-5-lower-assembly-timing-cam>



Material of Contact Parts

Contact Part	Material
Boot	MABS (Terlux HD 2822) plastic
Base Plate	S45C carbon steel
Tooling (Upper Punch, Lower Punch, and Die)	User specified
Ejection Tray	SUS304 stainless steel
Hopper	Polypropylene (PP) plastic

Technical Specifications

Number of dies	1
Production capacity	30-50/min
Max diameter of tablet	5-10 mm
Thickness of tablet	2-6 mm
Number of filling stations	1
Double layered tablet	No
Overall size	510 mm x 300 mm x 220 mm
Dimensions with suggested working clearance	1410 mm x 1200 mm x 1120 mm
Weight	24 kg

Maintenance Checklist

Before Operation	
<input type="checkbox"/>	Visually inspect the tablet press and the parts.
<input type="checkbox"/>	Ensure all locking nuts are tight.
<input type="checkbox"/>	Visually inspect grease nipples and regrease where necessary.
<input type="checkbox"/>	Tune the tablet press by hand to get the tablet size and weight correct.
<input type="checkbox"/>	Manually operate the machine for at least two full rotations to ensure it is not jammed.
During Operation	
<input type="checkbox"/>	Listen for irregular knocking or clicking sounds. If heard, stop operation and lubricate the machine.
<input type="checkbox"/>	Watch for buildup of powder in front of the Boot. If occurring, either (a) make mix more granular, (b) check the Boot's base for damage, or (c) clear the buildup with a paintbrush.
<input type="checkbox"/>	Ensure that the Hopper does not run out of powder.
<input type="checkbox"/>	Weigh a sample tablet and test for its hardness.
After Operation	
<input type="checkbox"/>	Remove all excess powder with a bagless vacuum.
<input type="checkbox"/>	Remove the Boot and the Tooling and clean the inside of the tablet press.
<input type="checkbox"/>	Wipe down the other surfaces with a damp cloth.
<input type="checkbox"/>	Apply a layer of food grade grease to the entire desktop tablet press.
<input type="checkbox"/>	Lubricate all grease nipples.
<input type="checkbox"/>	Store Tooling in an airtight box with a small amount of grease.

Diagrams

TDP 0[®] Mounting Diagram

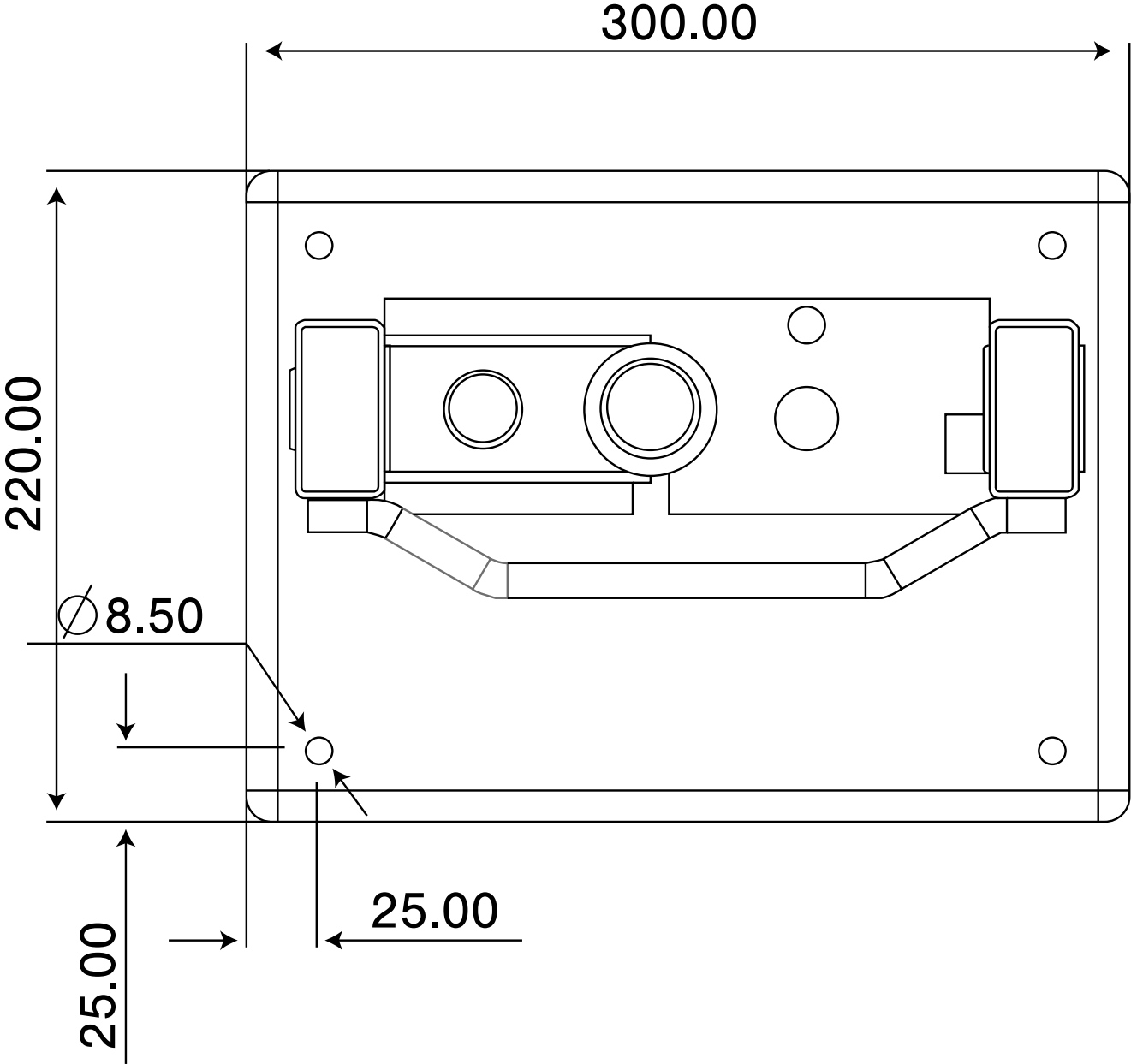

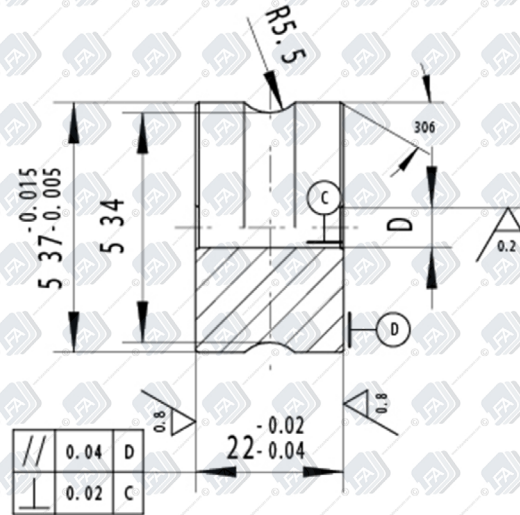
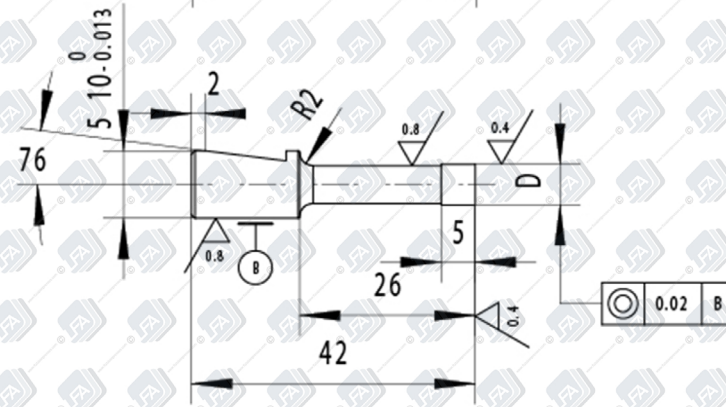
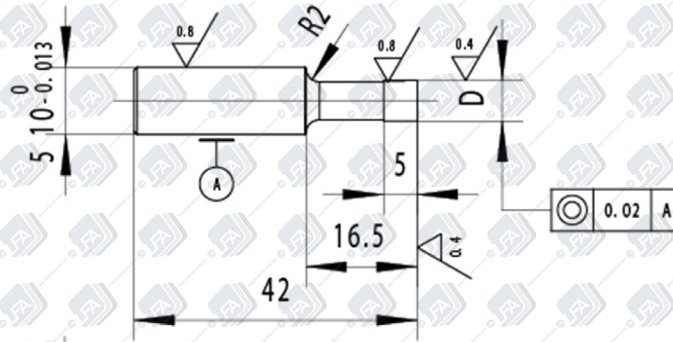

TDP® International Tooling Standard Dimensions

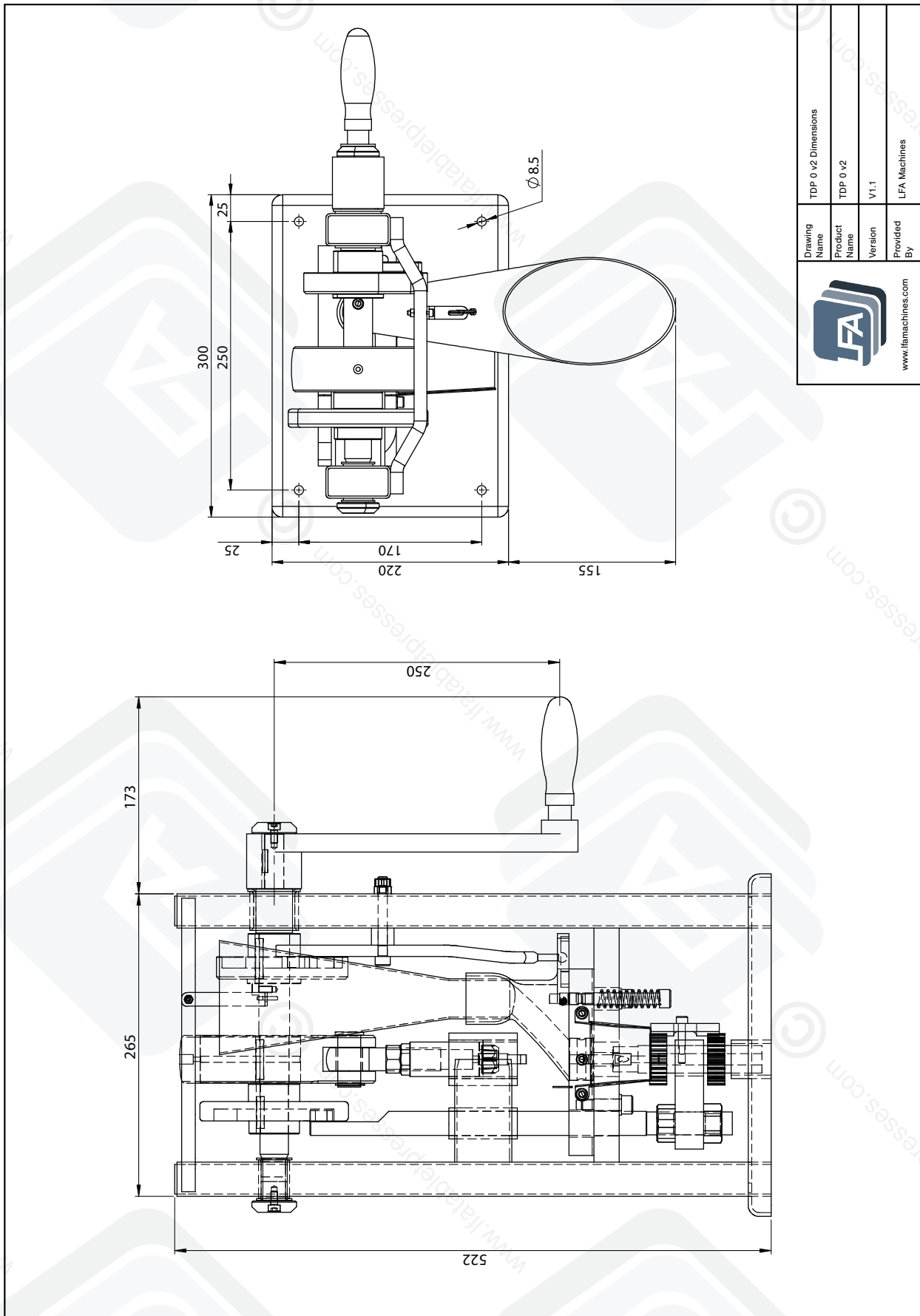

www.lfatabletpresses.com

TDP 0[®] Dimensions



 www.lfamachines.com	Drawing Name	TDP 0 v2 Dimensions
	Product Name	TDP 0 v2
	Version	V1.1
	Provided By	LFA Machines

TDP 0[®] Exploding Diagram

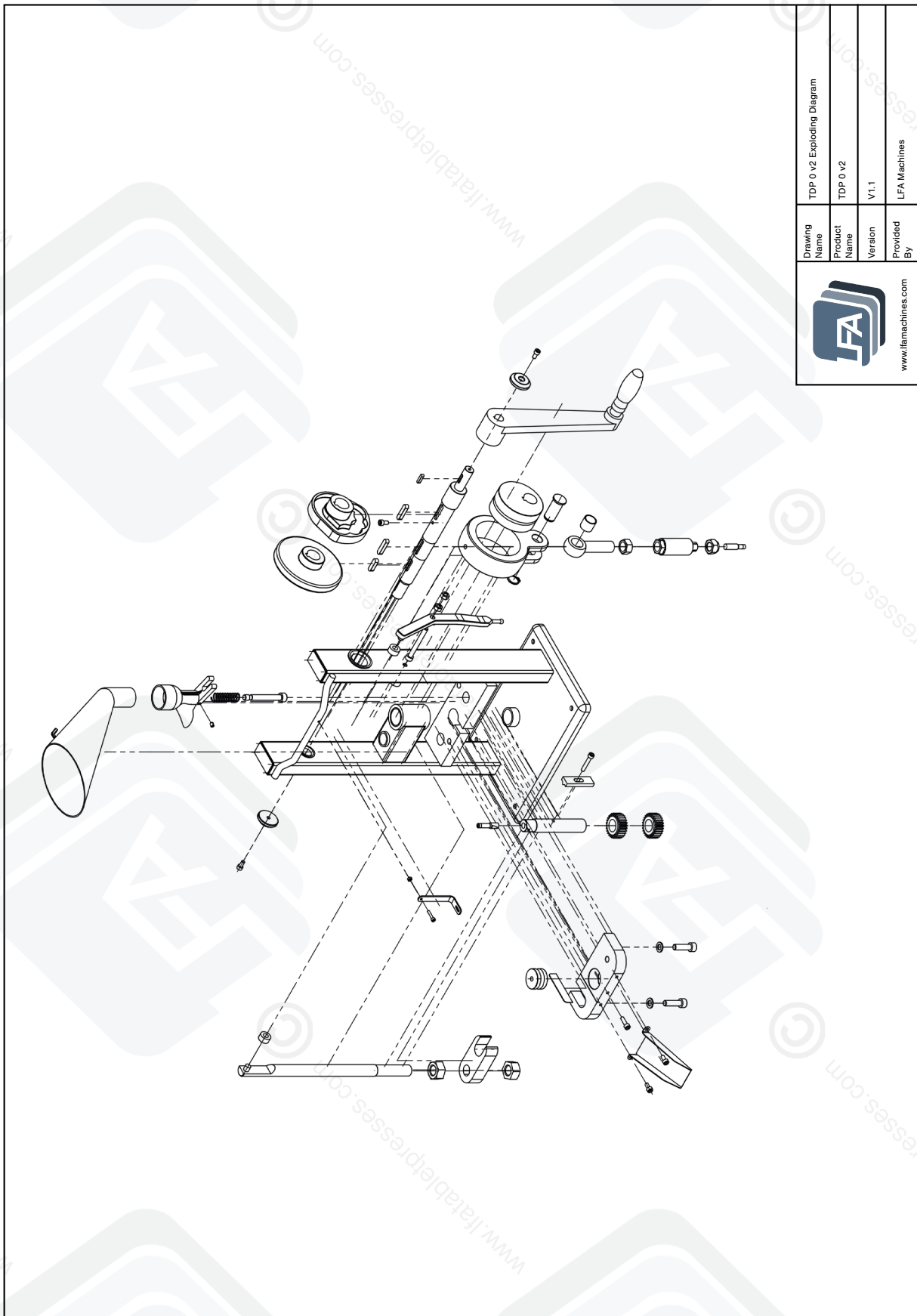

	Drawing Name	TDP 0 v2 Exploding Diagram
	Product Name	TDP 0 v2
	Version	V1.1
	Provided By	LFA Machines
		www.lfamachines.com

Resources

Helpful Links

Warranty

For information regarding the warranty policy of the TDP 0[®] and other LFA products, please visit <https://www.lfatabletpresses.com/warranty>

LFA Website

In order to aid you in your tablet production, LFA Machines maintains a website that offers a breadth of useful information about the TDP 0[®] and other tablet presses. Use our online tools such as the Tablet Mix Calculator to help you in your formulation production, or read our regularly published articles that cover a whole range of topics about tablet presses and tablet production.

Visit the LFA homepage at <https://www.lfatabletpresses.com>

LFA Machines YouTube Channel

Our YouTube videos provide you an opportunity to see how to use our tablet presses, common troubleshooting tips, and other LFA products such as capsule fillers and mixers. We regularly upload videos to give you a visual aid that will hopefully support you in your tablet production efforts. To watch our videos, visit <https://www.youtube.com/channel/UCwtbcwja77ai7vX2o34FUKQ>

LFA Machines Social Media

Social media is a great way to keep yourself updated on new developments and exciting things happening at LFA Machines. The list below contains our current social media pages:

Twitter: @lfatabletpresses

Instagram: @lfatabletpresses

Facebook: <https://www.facebook.com/lfatabletpresses>

LinkedIn: <https://www.linkedin.com/company/lfa-machines-oxford-ltd/>

Contact Us

UK

LFA Machines Oxford Ltd
Unit 4B Rowood Estate
Murdock Road
Bicester, Oxfordshire OX26 4PP
+44 01869 250234
support.uk@lfamachines.com
Monday-Friday
9AM-5PM GMT

USA

LFA Machines DFW, LLC
6601 Will Rogers Blvd
Fort Worth, TX 76140
+1 (682) 312 0034
support.usa@lfamachines.com
Monday-Friday
8AM-6PM UTC (Central)

Germany

LFA Machines Düsseldorf GmbH
Business Parc Am Trippelsberg 92
Düsseldorf, North-Rhine
Westphalia 40589
+41 21188250223
verkauf@lfamachines.com

Taiwan

LFA Machines Taiwan Ltd
7F-5, No. 2, Sec. 2 Taiwan Blvd
West District, Taichung City 403
Taiwan
+886 422031790
support.asia@lfamachines.com
Monday-Friday
9AM-5PM GMT+8



LFA MACHINES

Copyright © 2022 by LFA Machines

www.lfamachines.com

United Kingdom

Unit 4B
Murdock Road
Bicester
Oxfordshire
United Kingdom
OX26 4PP

United States

6601 Will Rogers Blvd
Fort Worth
Texas
United States
76140

Germany

Business Parc Am
Trippelsberg 92
Düsseldorf
Germany
40589

Taiwan

7F.-5, No. 2, Sec. 2
Taiwan Blvd., West Dist.,
Taichung City 403,
Taiwan