

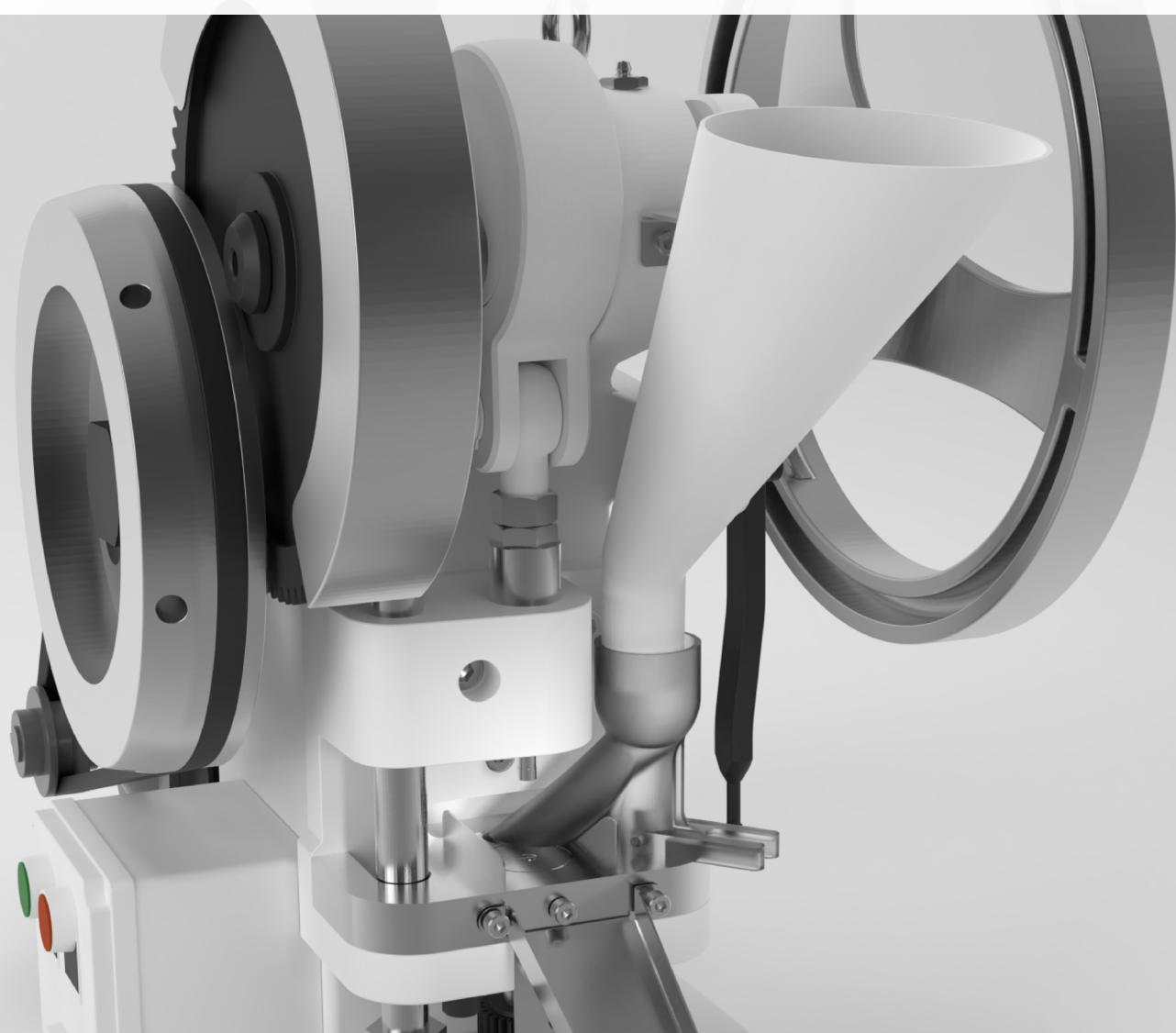

# TDP 5<sup>®</sup> Tablet Press User Manual



We don't just sell machines—  
we provide service.

# Copyright Notice

© LFA Machines Oxford Limited, published in 2022 by LFA Machines Oxford Limited 2022. Registered in England and Wales, company number 08428898, registered office for service Demar House 14 Church Road East Wittering, Chichester, West Sussex, PO20 8PS.

All rights reserved. No part of this publication may be reproduced or transmitted, in any form or by any means, or stored in any retrieval system of any nature, without prior permission, except for fair dealing under the Copyright, Designs and Patents Act 1988, or in accordance with the terms of license issued by the Copyright Licensing Agency in respect of photocopying and/or reprographic reproduction. Application for permission for other use of the copyright material including permission to reproduce extracts in other published works shall be made to the publisher. Full acknowledgment or author, publisher and source must be given.

All trade marks are acknowledged and are owned by their respective owners.

# Important Safety Information

## READ THIS BEFORE OPERATING MACHINE

### Intended Use

The intended use of this machine is to press dry raw materials into tablet form.

Potential misuse of this machine includes:

- Applying too much force to the powder.
- Trying to fill the Die with powder by hand.
- Inserting Tooling that is too big for the machine.
- Not properly mounting the machine.
- Using powders that could explode under pressure.
- Using wet or damp material.

### Personal Protection

For personal protection while transporting the TDP 5<sup>®</sup>, abide by these actions:

- Use an engine hoist to lift the machine.
- Wear steel toe boots to prevent foot injury.
- Wear heavy duty grip gloves to ensure firm grasp on machine.
- Wear back support belt to prevent injury if needed.

For personal protection while operating the TDP 5<sup>®</sup>, abide by these actions:

- Avoid wearing loose jewelry to prevent machine entanglement.
- Contain long hair to prevent machine entanglement.
- Wear safety goggles.
- Wear disposable latex/rubber gloves.
- Wear a hairnet (food grade products only).
- Wear a beard net if needed (food grade products only).

### General Hazards

- Be aware of risk of entanglement and pinch point due to moving parts.
- Do not operate in a wet environment or with wet hands due to risk of electrical shock or burn.
- Do not operate if any wires are damaged, pinched, or frayed due to risk of electrical shock or burn.
- Keep out of reach of children.
- Keep fingers away from all moving parts.
- Ensure that it is secured to a workbench to prevent from falling.
- Inspect machine before use.
- Check that nuts and bolts are suitably tightened.
- Use this machine only for its intended use as described in this manual.
- Turn off and unplug the machine before conducting cleaning and maintenance.
- Do not modify the machine in any way.

# Important Safety Information

**READ THIS BEFORE OPERATING MACHINE**

## Symbols



**WARNING**

This signals potential risk for personal injury.



**WARNING**

This signals potential risk for electrical shock.



**CAUTION**

This signals potential risk for damage to the machine or other parts.

## Modes for Stopping

In the case of an emergency during manual operation, immediately stop turning the Hand Wheel and remove yourself from the TDP 5<sup>®</sup>.

In the case of an emergency during motor operation, immediately press the red OFF button (see below) and unplug.

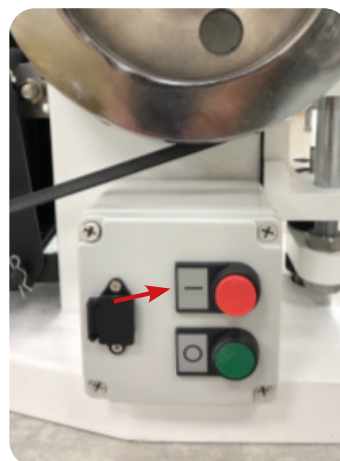

## Prop. 65 Statement for CA Residents

Based on LFA's current level of knowledge of our machines, the TDP 5<sup>®</sup> does not require a Proposition 65 warning label.



# Important Safety Information

## READ THIS BEFORE OPERATING MACHINE

### Installation and Safety Assessment

Due to the nature and design of this machine and its intended use in an industrial environment, it is important that before use it is installed in a cage with a mode of stopping on the outside of the cage. LFA Machines has decided that we can not possibly foresee all of the environments or situations in which this machine could be used or installed and therefore have determined that the end user must install the machine in a way that is appropriate and safe for its use.

Once the machine has been installed, it is critical that you conduct a safety assessment to ensure that it complies with all local and industry accepted safety regulations.

If you require guidance on the installation of the machine or conducting a safety assessment, please contact LFA Machines.

This machine is sold as an Unfinished Machine under the Machinery Directive (2006/42/EC) Article 13.

### Warning for Explosive Material

This machine is not explosion proof. LFA recommends that you test your materials' explosivity before running them through this machine. If your materials are indeed explosive, do not use them with this machine.

# Table of Contents

<b>Copyright Notice</b>	<b>2</b>
<b>Important Safety Information</b>	<b>3</b>
Intended Use	3
Personal Protection	3
General Hazards	3
Symbols	4
Modes for Stopping	4
Prop. 65 Statement for CA Residents	4
Installation and Safety Assessment	5
Warning for Explosive Material	5
<b>TDP 5® Parts List</b>	<b>9</b>
<b>Preface</b>	<b>10</b>
<b>Training</b>	<b>11</b>
Off-Site Training	11
Training via Video Chat/Phone	11
LFA Articles	11
LFA Videos	11
<b>Installation</b>	<b>12</b>
Tools and Materials Needed	12
The Appropriate Workstation for the Machine	12
Assembly	15
Mounting the TDP 5®	16
Manual and Electrical Controls	18
Settings and Adjustment	21
<b>Maintenance</b>	<b>28</b>
General Maintenance Prescriptions	28
Lubrication	28
Dismantling for Repair and Replacement	32
Wear Parts and Causes of Damage	32
Tooling	33
Boot Timing Bar	39
Boot	42
Upper Drift Pin Assembly	44
Upper Drift Pin Assembly Rod Eye and Clevis	51
Lower Drift Pin Assembly	58
Lower Drift Pin Assembly Timing Rod and Runner Bolt	66
V Belt	69
Hand Wheel	71
Electrical Drive Flywheel	72
Boot Timing Cam	75
Pinion Gear	79
Cam Drive Cog	83
Drive Belt Pulley	88
Motor	90
Top Cam Drive Shaft	94

# Table of Contents - Continued

<b>Troubleshooting</b>	<b>99</b>
Common Machine/Part Issues	99
Common Tablet Issues	101
De-Jamming the TDP 5®	102
Cleaning	107
Storing the TDP 5®	112
<b>Appendix</b>	<b>114</b>
Glossary	114
Description of TDP 5® Parts	115
List of Electrical Components	122
Material of Contact Parts	122
Technical Specifications	122
Maintenance Checklist	123
Diagrams	124
Resources	130

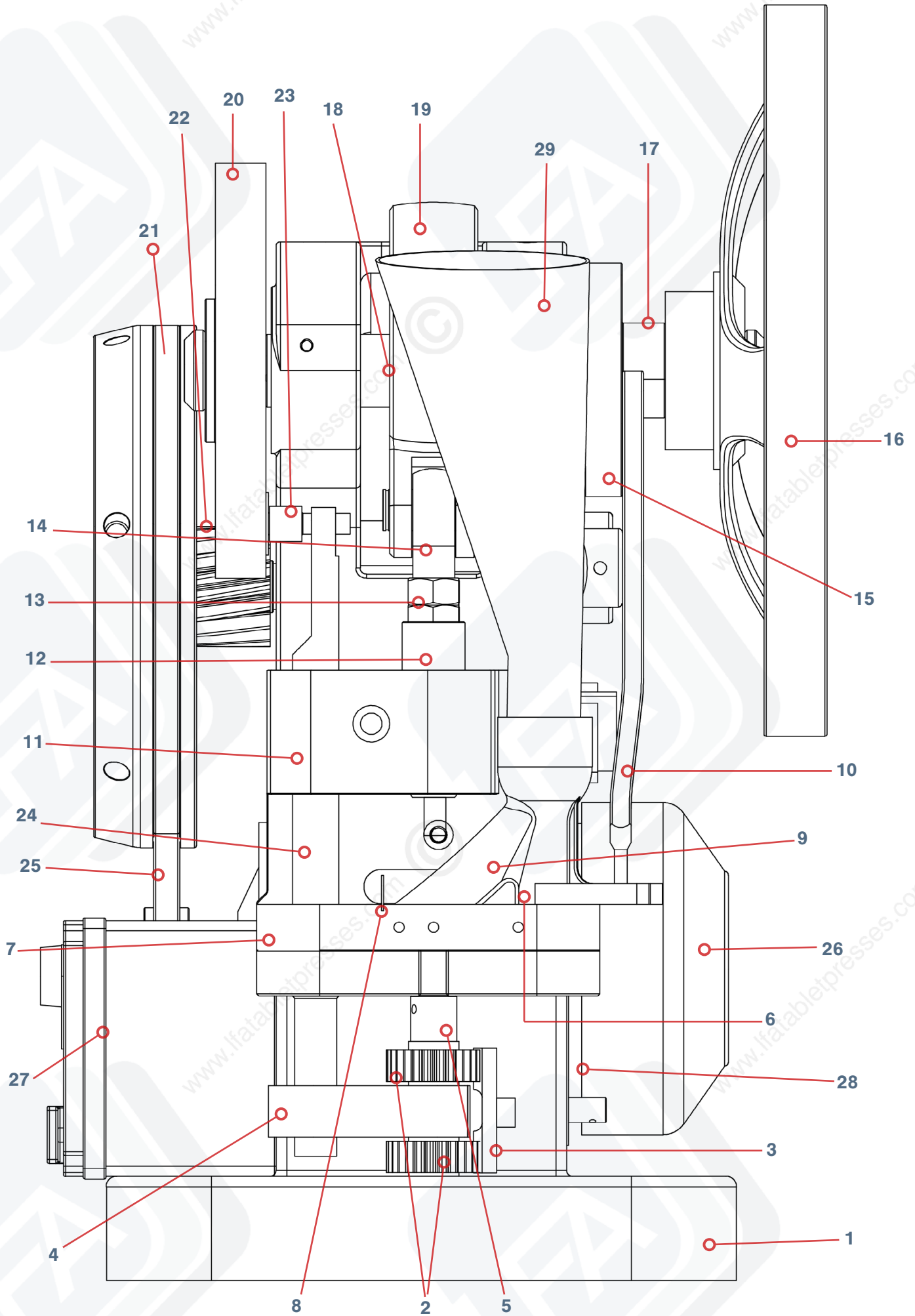

# TDP 5<sup>®</sup> Parts List

1. TDP 5<sup>®</sup> Base (#AEC0000)
2. Lower Drift Pin Assembly Cogs (#AEC0012)
3. Lower Drift Pin Assembly Locking Bar (#AEC0013)
4. Lower Drift Pin Assembly Lifting Bar (#AEC0034)
5. Lower Drift Pin Assembly (#AEC0011)
6. Boot Bolt and Spring (inside Boot) (#AEC0051; #AEC0055)
7. Base Plate (#AEC0008)
8. Ejection Guard (#AEC0009)
9. Boot (#AEC0036)
10. Boot Timing Bar (#AEC0018)
11. Upper Drift Pin Assembly Mounting Block (#AEC0010)
12. Upper Drift Pin Assembly (#AEC0002)
13. Upper Drift Pin Assembly Locking Nut (#AEC0006)
14. Upper Drift Pin Assembly Rod Eye and Clevis (#AEC0005)
15. Boot Timing Cam (#AEC0038)
16. Hand Wheel (#AEC0046)
17. Top Cam Drive Shaft (#AEC0037)
18. Eccentric Sheave (#AEC0033)
19. Eccentric Sheave Strap (#AEC0004)
20. Cam Drive Cog (inside Cam Drive Cog Safety Cover) (#AEC0050)
21. Electrical Drive Flywheel (#AEC0021)
22. Pinion Gear (#AEC0022)
23. Lower Drift Pin Assembly Timing Rod Runner Bolt (#AEC0015)
24. Lower Drift Pin Assembly Timing Rod (#AEC0014)
25. V Belt (Drive Belt) (#H108012028)
26. Motor (#AEC0042)
27. Electrical Box and Connecting Cables (#AEC0053)
28. Motor Mounting Plate (#AEC0041)
29. Hopper (#AEC0030)

# Preface

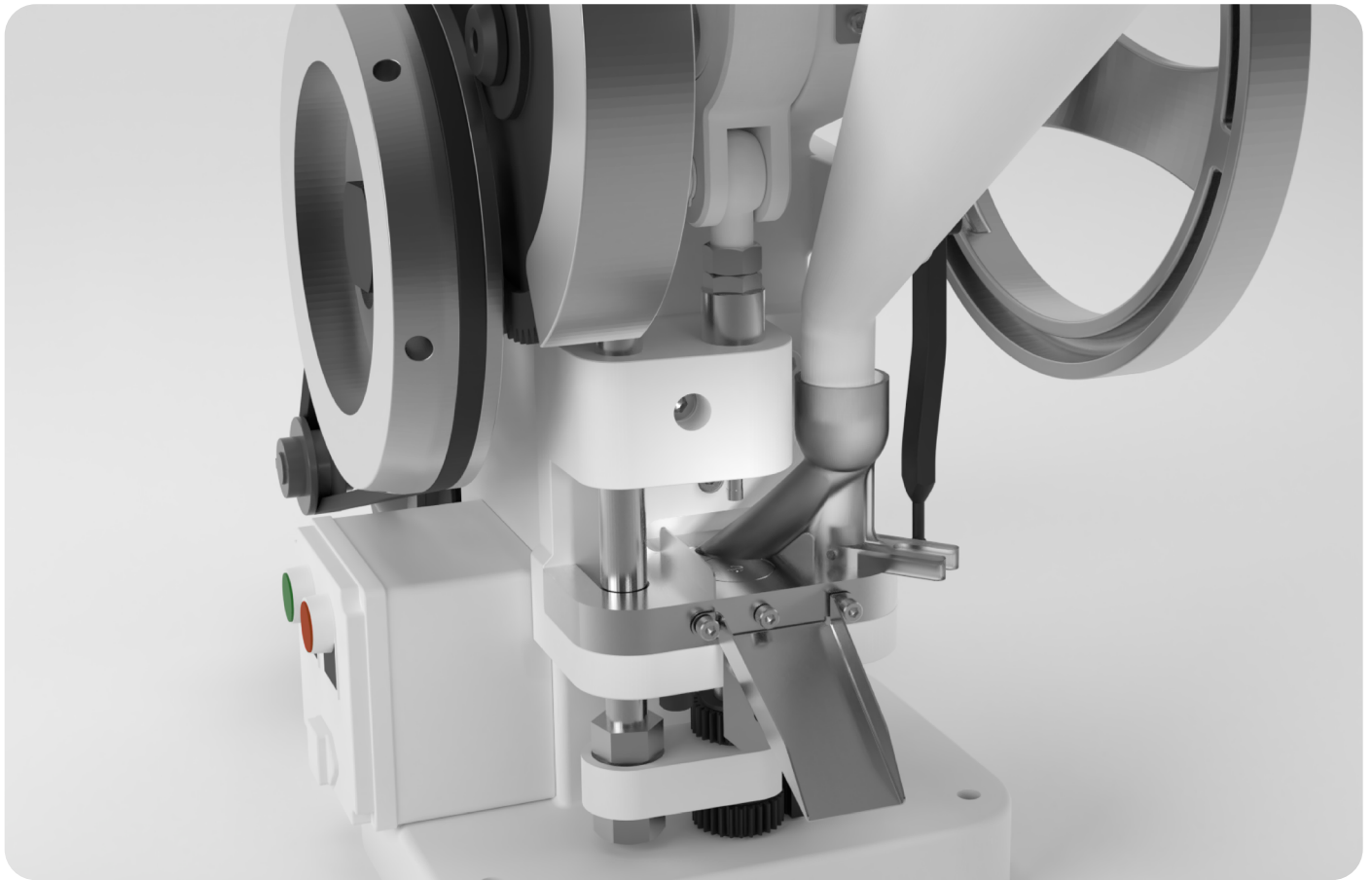

The TDP 5<sup>®</sup> Tablet Press has the ability to press small quantities of tablets in a wide variety of sizes from a powder formulated with dry granular materials and an excipient. By generating up to 50 kN of pressure with either electrical or manual power, the TDP 5<sup>®</sup> can produce up to 4,800 tablets an hour with interchangeable dies. This machine can create most types of tablets, including irregularly shaped pills, up to 20 mm in diameter and 8 mm thick. Useful for work in the field and on location, the TDP 5<sup>®</sup> is popular with a range of industries such as hospitals, research facilities, and laboratories in the pharmaceutical, food, and chemical industries.

The purpose of this document is to support your understanding of the TDP 5<sup>®</sup>'s components, features, functions, and design. With this manual, you will be able to successfully operate and maintain your TDP 5<sup>®</sup> machine.

The user manual's content includes:

- Important safety information
- TDP 5<sup>®</sup> installation instructions
- Description of the TDP 5<sup>®</sup>'s operation
- TDP 5<sup>®</sup> maintenance information
- Appendix with supplemental information

# Training

TDP 5<sup>®</sup> training is essential for the machine's successful operation and your personal safety. There are several methods to prepare you for working with the TDP 5<sup>®</sup>.

## Off-Site Training

LFA offers free training at our UK, USA, and Taiwan facilities for all our customers and their teams. For more information, go to <https://www.lfatabletpresses.com/services>

## Training via Video Chat/Phone

Using an online video chat system, an LFA technician can interact face-to-face with you and assist with your understanding of the machine. Or, if you prefer, LFA can provide training via phone for all customers who call the office. To set up a training, call or email your local LFA office:

### UK

#### Phone

+44 01869250234

#### Email

[support.uk@lfamachines.com](mailto:support.uk@lfamachines.com)

### USA

#### Phone

+1 (682) 312-0034

#### Email

[support.usa@lfamachines.com](mailto:support.usa@lfamachines.com)

### Taiwan

#### Phone

+886 422031790

#### Email

[support.asia@lfamachines.com](mailto:support.asia@lfamachines.com)

## LFA Articles

LFA writes informative articles about desktop tablet presses, which includes instructions, procedures, and guides. To access the articles, go to <https://www.lfatabletpresses.com/articles>

## LFA Videos

LFA has created several videos involving the TDP 5<sup>®</sup> and other desktop tablet presses. To access the videos, go to <https://www.lfatabletpresses.com/videos> or <https://www.youtube.com/user/TabletPilPress>

# Installation

## Tools and Materials Needed

Before you install and operate the TDP 5<sup>®</sup>, it is best to have the following tools and materials on hand for general operation and maintenance:

- Engine hoist or lift and lifting strap
- Mounting materials such as:
  - Non-slip pad (such as a yoga mat cut to fit the machine's base) OR anti-vibration pads
  - Power drill
- Hammer
- Gear puller
- Rubber mallet
- Copper pipe around 22 mm in diameter
- Metric wrench set
- Circlip pliers
- Pliers/grippers
- Flathead screwdriver
- Set of metric Allen keys with ball ends
- Long wire pipe cleaner
- Lubricant (NSF approved for food grade products)
- Grease gun
- Toothbrush
- Bagless vacuum
- Sanitizer (e.g. Member's Mark Commercial Sanitizer)
- Cleaning brush set
- Plastic sheet or something similar to cover machine
- Safety goggles
- Disposable latex/rubber gloves
- Hairnet and/or beard net (food grade products only)
- Sterile shoe covers (food grade products only)

## The Appropriate Workstation for the Machine

Find a stable workspace surface that supports the TDP 5<sup>®</sup>'s 125 kg (about 275 lbs) weight, such as a wooden bench (use stainless steel if for food grade industry). Another important thing to consider is to find a bench that has a suitable working height for you. This machine also has a single phase 240 V or 110 V ( $\pm 10\%$ ) electrical requirement, so ensure that it is near an appropriate power plug.

### Environmental Conditions

It is important that the environment in which you operate and store the TDP 5<sup>®</sup> has the appropriate temperature and relative humidity levels. These two environmental factors can potentially cause the machine to rust and/or cause the tablets to have a lower quality. The table below shows the acceptable temperature and relative humidity levels:

Machine	Temperature		Humidity
	°C	°F	
TDP 5	18-24	64-75	45-65% RH



The shipping crate will contain the following:

1. The assembled TDP 5<sup>®</sup>

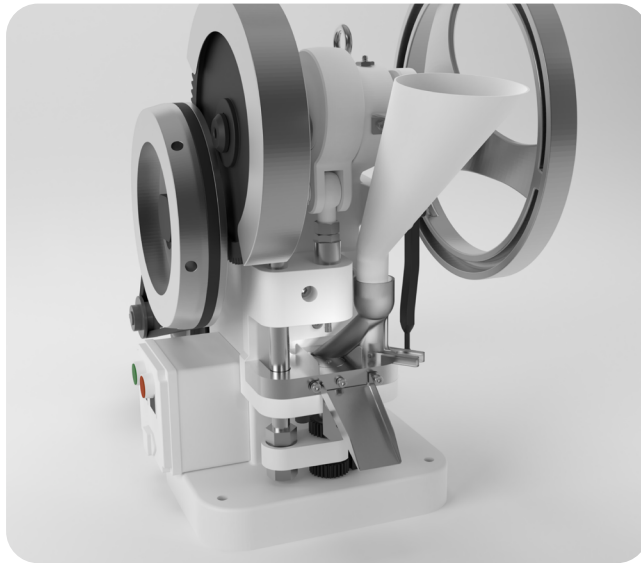

2. The Tooling (already installed)

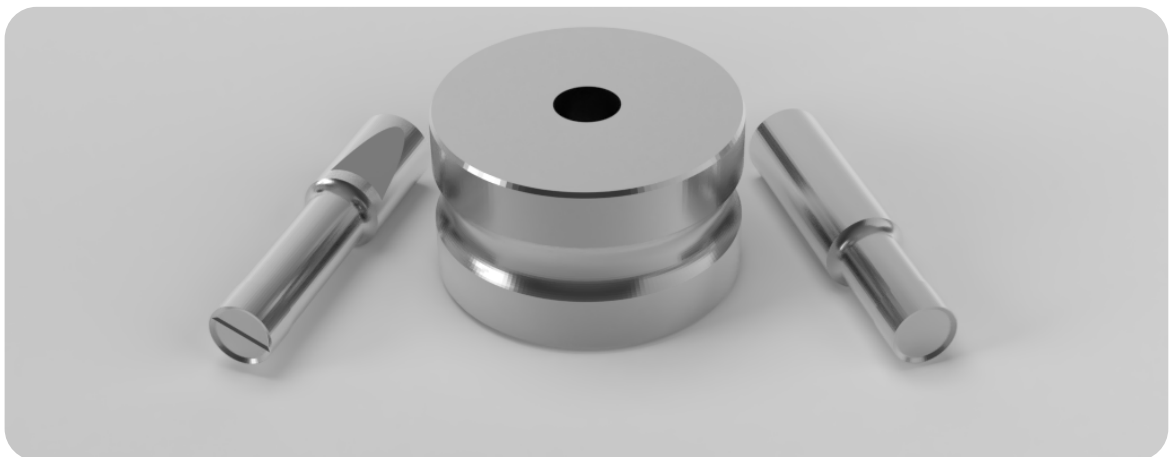

3. The Hopper

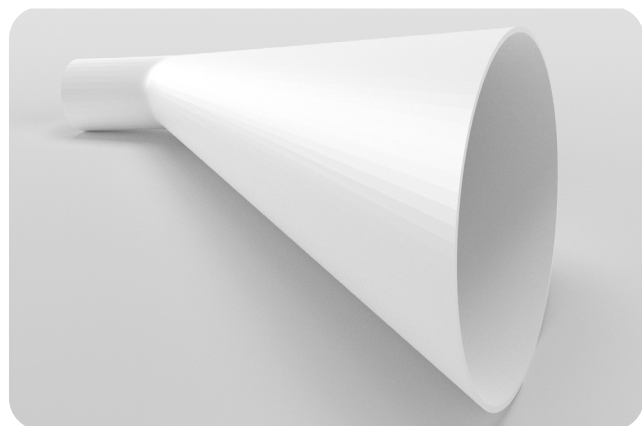

4. The De-Jamming Bar

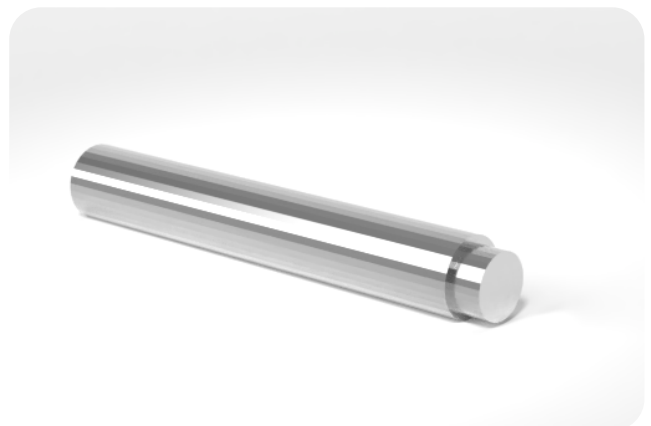

Note: The Hand Wheel Handle is packaged with the De-Jamming Bar.

## Unpacking the TDP 5®

Watch a video of a TDP 5® unboxing at <https://www.lfatabletpresses.com/videos/tdp-5-unboxing-setup>

### Tools Needed

- Flathead screwdriver
- Hammer
- 17 mm wrench

### Instructions

1. Pry open each of the clips on the shipping container with a flathead screwdriver.



1.1 Note: Hammer the clips even further down to aid in removing the shipping container from the base.

2. Lift the top of the shipping container from its base, which is bolted to the TDP 5®.
3. Remove the plastic wrapping and set the Hopper aside.  
3.1 Note: Save the wrapping for future transport and/or storage.
4. Remove the bolts from the shipping container's base with a wrench.



4.1 Note: Keep the bolts and the shipping container's base in case you need to move or relocate the TDP 5®.

## Assembly

The TDP 5<sup>®</sup> comes almost fully assembled. Insert the Hopper into the Boot like so:

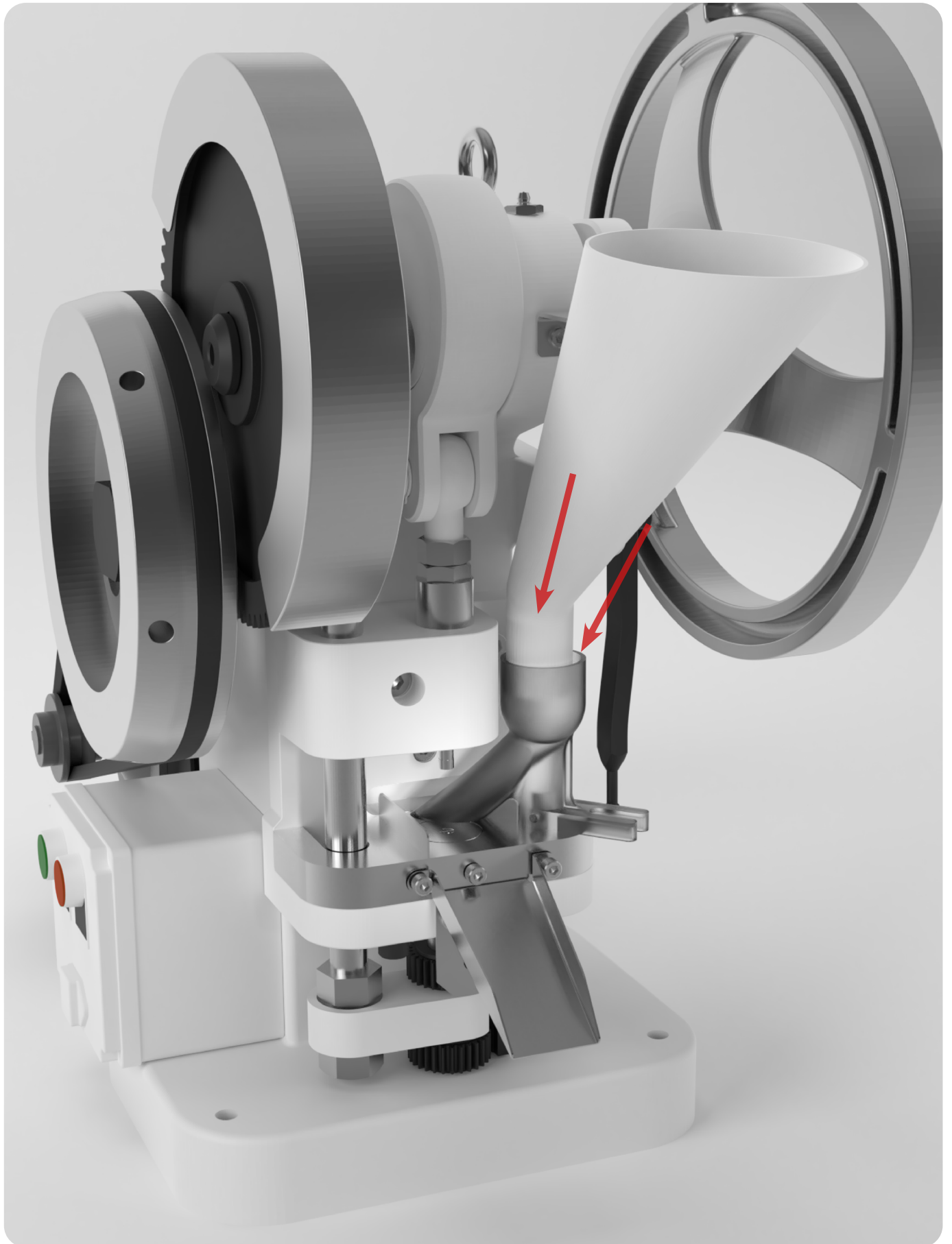

## Mounting the TDP 5<sup>®</sup>

**WARNING:** To prevent personal injury, wear steel toe boots and heavy duty grip gloves while transporting the TDP 5<sup>®</sup>.



LFA does NOT recommend carrying the machine manually but rather with an engine hoist. At least two people should be involved (one operating the engine hoist and one stabilizing the machine) in removing the machine from the shipping container and placing it in the workspace.

## Transporting the TDP 5<sup>®</sup>

### Tools and Materials Needed

- Engine hoist and lifting strap

### Instructions

1. Secure the engine hoist onto the eyelet bolt attached to the top of the TDP 5<sup>®</sup> Base.

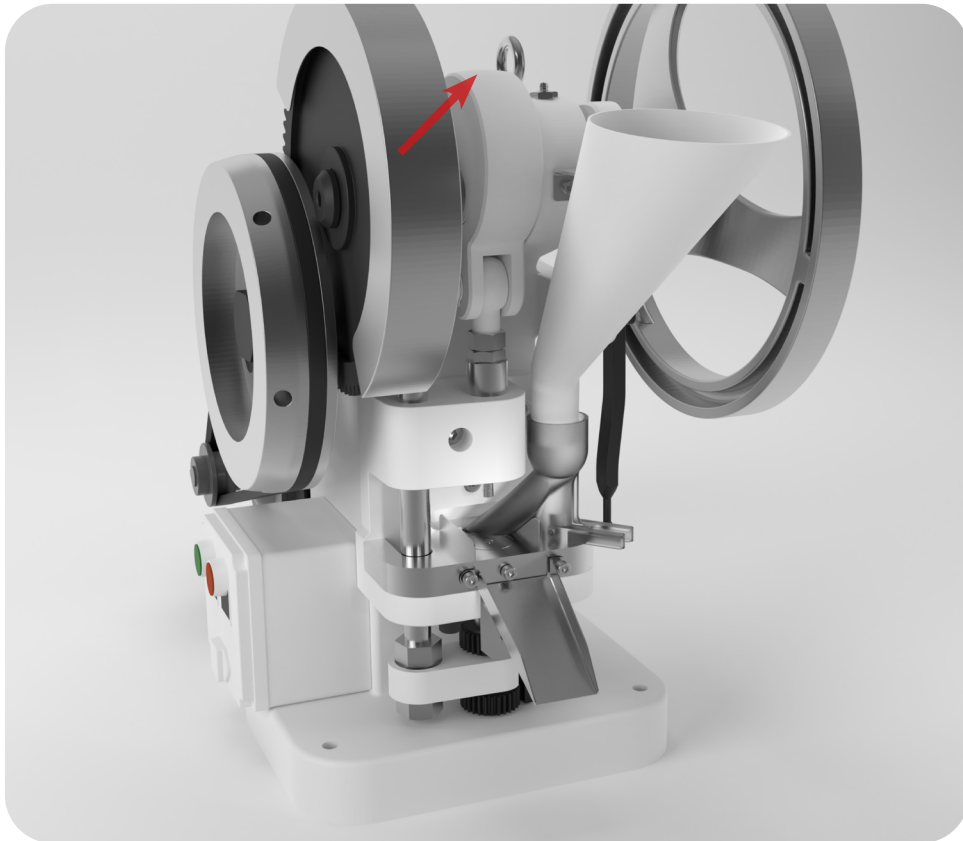

2. Wrap the lifting strap to support both the bottom and top of the TDP 5<sup>®</sup>.
3. Carefully transport the machine to the desired workspace.

## Bolting the TDP 5<sup>®</sup>

The TDP 5<sup>®</sup> Base comes with three bolts and three bolt holes. Because the machine's movement could cause it to fall off the workspace surface during operation, which creates potential for injury to self and to the machine, it is important to ensure that it will not move by bolting down the TDP 5<sup>®</sup>. There are other options as well that can prevent the TDP 5<sup>®</sup> from moving, which are described below:

### Non-Slip Pad

Placing a pad or mat that grips the surface underneath the TDP 5<sup>®</sup> will stabilize any movement. What works well is anything similar to a yoga mat. Simply cut the pad to a size that is slightly bigger than the TDP 5<sup>®</sup>'s base, and then bolt the base through the mat and into the workspace surface.

### Anti-Vibration Pads

Anti-vibration pads underneath the TDP 5<sup>®</sup>'s base not only absorb noises and vibrations, but also reduce the machine's movement. Similar to using a non-slip pad, the anti-vibration pads also need to be bolted through into the workplace surface.



**WARNING:** Anti-vibration pads with feet indentations, such as those used for washing machines, are not suitable for the TDP 5<sup>®</sup>. They may cause the machine to lose its balance and fall off the workspace surface, potentially resulting in personal injury.

Note: Before bolting the machine to the workspace surface, ensure that an appropriate electrical outlet (240 V or 110 V) is nearby.

Once you have determined where the bolts will be, drill three holes into the workspace surface. Then, insert the bolts through the TDP 5<sup>®</sup>'s base and the workspace surface and tighten them as necessary.

**In accordance with Article 13 of the European Directive 2006/42/EC, LFA Machines sells the TDP 5<sup>®</sup> as a partly finished machine, and it is meant to be installed into and function as a part in a production line.**

**After the installation of this machine, the following measures need to be taken:**



- **Shields must be installed in order to cover moving parts, those being in particular the Upper Punch, Upper Drift Pin Assembly, Lower Drift Pin Assembly, Boot, Top Cam Assembly, Hand Wheel, Electrical Drive Flywheel, and V-Belt.**
- **An emergency stop/emergency lockout/isolator switch must be installed on the outside of the machine.**
- **A risk assessment must be conducted on the entire production line.**

**If you require guidance on the installation of the machine or conducting a safety assessment, please contact LFA Machines.**

# Manual and Electrical Controls

## Basic Components

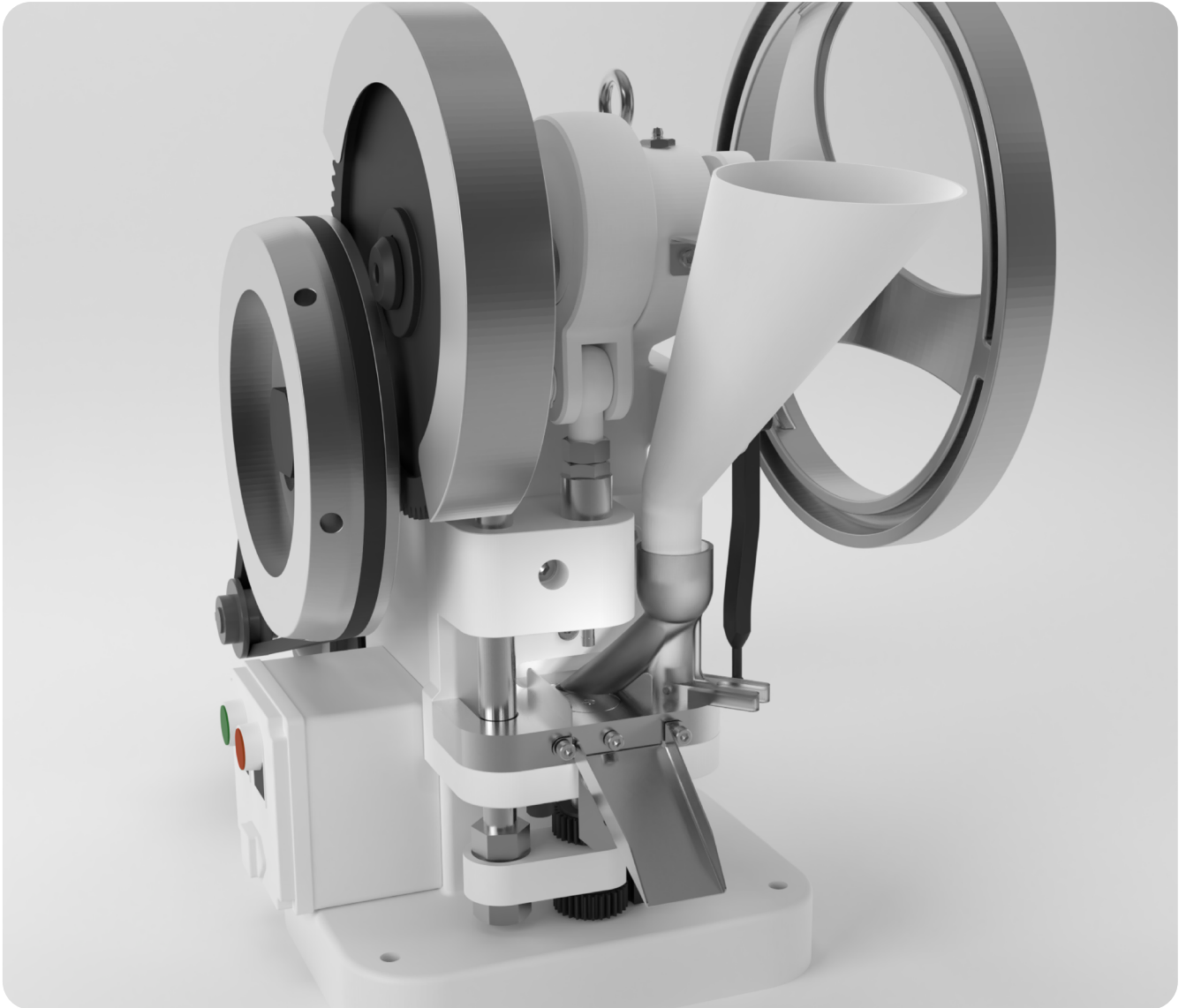

A description of the principal components follows:

- The **Hand Wheel** can be turned to start the cam track's direction.
- The **Top Cam Drive Shaft** guides the punches' movement.
- The **Hopper** holds the dry materials that will be compressed.
- The **Boot** moves the materials from the Hopper to the Tooling and ejects the tablets.
- The **Die** defines or molds the size and shape of the powder.
- The **Upper Punch** and **Lower Punch** compress the materials within the Die.



## **TDP 5<sup>®</sup> Process**

The basic mechanism of the TDP 5<sup>®</sup> involves filling the Tooling (Die, Upper Punch, and Lower Punch) with powder, compressing the powder, and ejecting the tablet.

### **Filling the Tooling with Powder**

The dry materials are poured into the Hopper, which funnels the powder into the Boot. As the Hand Wheel is manually operated, the Top Cam Drive Shaft withdraws the Upper Punch from the Die.

When the machine is operated by the motor, the Gearing initiates the movement of the Top Cam Drive Shaft, which withdraws the Upper Punch from the Die and sets the Lower Punch at the level at which the fill depth is adjusted.

### **Compressing the Powder**

After the powder is filled in the Tooling, the Top Cam Drive Shaft drives the Upper Punch into the Die, which creates high pressure between both punches that allows the tablet to be compressed.

### **Ejecting the Tablet**

After both punches compress the powder into a tablet, the Top Cam Drive Shaft withdraws the Upper Punch while the Lower Punch is pushed upward to expel the tablet. The tablet is then pushed out of the way by the Boot to prepare for the next tablet compression.

## How to Create Tablets with the TDP 5®

### Tools and Materials Needed

- Raw material formulation
- Fully assembled TDP 5® with Hopper
- Safety goggles
- Disposable latex/rubber gloves (for food grade products and to protect hands from grease)
- Hairnet and/or beard net (food grade products only)
- Sterile shoe covers (food grade products only)



**WARNING:** For personal protection while operating the TDP 5®, contain long hair and do not wear loose jewelry.

### Instructions

Note: Wear latex/rubber gloves (and appropriate food grade attire if applicable) during this process.

1. Adjust the fill depth and punch pressure to the lowest level.
2. Pour the dry materials into the Hopper.
  - 2.1 Note: Ensure that the TDP 5® is unplugged from the electrical outlet.
3. Rotate the Hand Wheel in the direction indicated by the arrow located on the Cam Drive Cog Safety Cover.
  - 3.1 Note: Always manually operate the TDP 5® for one rotation of the Top Cam Drive Shaft to ensure that it is operating correctly.
4. Adjust the fill depth and punch pressure until the tablet is at the desired weight and thickness.
5. Plug in the TDP 5® to an electrical outlet.
6. Press the green button (O) to start the TDP 5 and the red button (—) to turn off the TDP 5®.





## Settings and Adjustment

The TDP 5®'s settings can be adjusted. Tuning the Tooling can help with changing the tablets' characteristics and how they are ejected from the machine.

### Ejection Height

When the Upper Punch is fully lifted, the Lower Punch in its highest position should be flush with the Die:

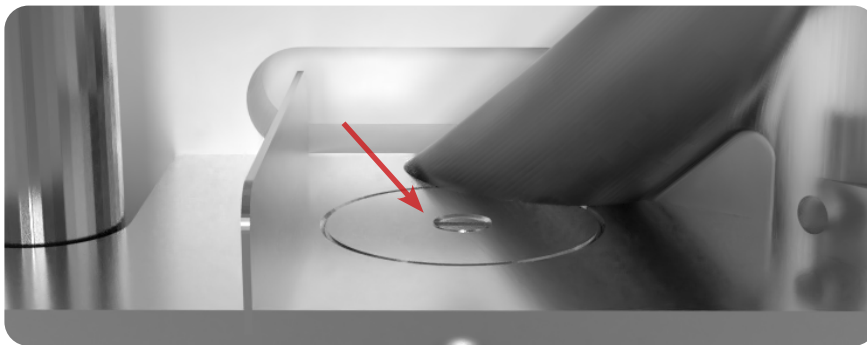

If the Lower Punch is above or below the Die's face, it will affect how smoothly the tablet is ejected. Adjusting the ejection height will help with this and can vary with different forms of Tooling.

### Tools and Materials Needed

- Set of metric Allen keys with ball ends
- Disposable latex/rubber gloves (for food grade products and to protect hands from grease)
- Hairnet and/or beard net (food grade products only)
- Sterile shoe covers (food grade products only)



**WARNING:** To prevent any potential personal injury, unplug the TDP 5® from the electrical outlet

### Instructions

Note: Wear latex/rubber gloves (and appropriate food grade attire if applicable) during this process.

1. Produce a test tablet to determine how the Tooling should be adjusted.
2. Remove the Ejection Tray with an Allen key.

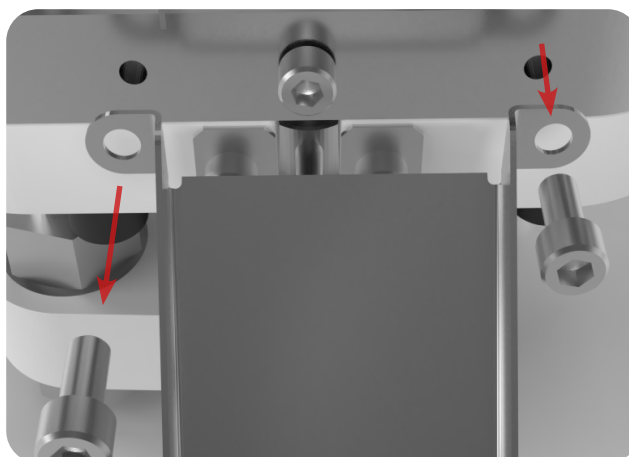

3. Remove the Lower Drift Pin Assembly Locking Bar bolt with an Allen key.

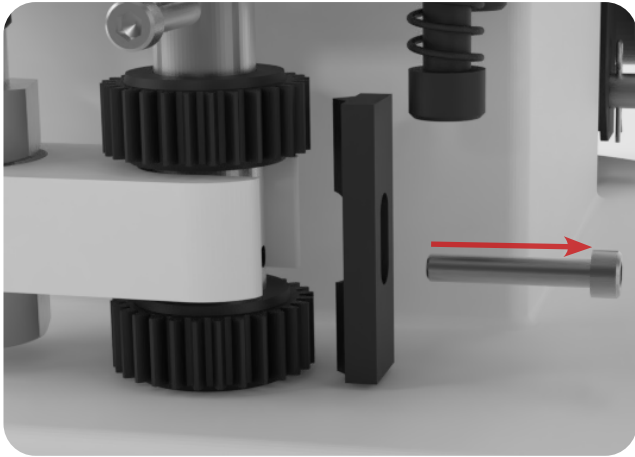

4. Rotate the Upper Cog in the Lower Drift Pin Assembly by hand.

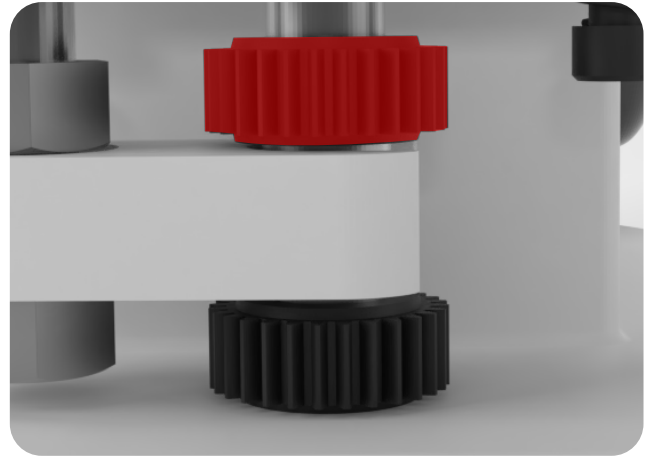

4.1 Note: To raise ejection height, turn clockwise. To lower ejection height, turn counterclockwise.

5. Run an ungloved finger over the Base Plate to ensure the Die is flush.

6. Secure the bolt in the Lower Drift Pin Assembly Locking Bar with an Allen key.

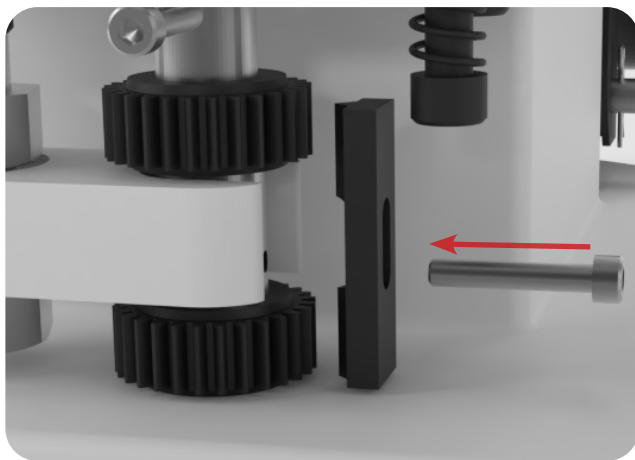

6.1 Note: Ensure that the Lower Drift Pin Assembly Locking Bar is situated vertically.

7. Reattach the Ejection Tray to the TDP 5®.

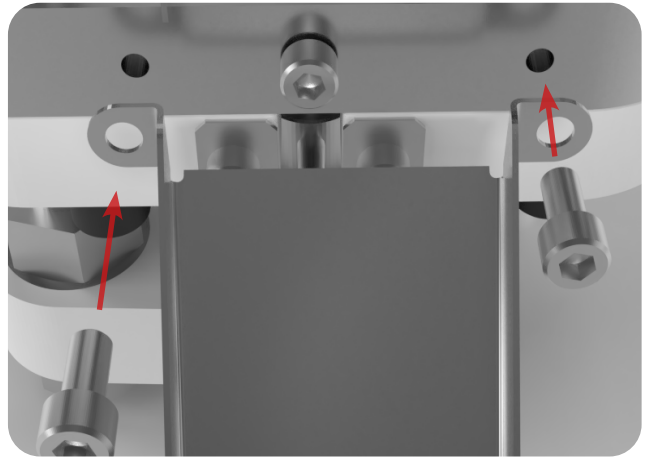

## Fill Depth

At times, a tablet will be too light or too heavy, and its weight must change. Adjusting the fill depth determines the tablet's thickness and weight. This can be controlled by changing how high or low the Lower Punch sits.

### Tools and Materials Needed

- Set of metric Allen keys with ball ends
- Disposable latex/rubber gloves (for food grade products and to protect hands from grease)
- Hairnet and/or beard net (food grade products only)
- Sterile shoe covers (food grade products only)

### Instructions

Note: Wear latex/rubber gloves (and appropriate food grade attire if applicable) during this process.



**WARNING:** To prevent any potential personal injury, unplug the TDP 5<sup>®</sup> from the electrical outlet.

1. Produce a test tablet to determine how the Tooling should be adjusted.
2. Rotate the machine until the Lower Drift Pin Assembly is at its highest position and the Boot is at the position to eject the tablet.
3. Remove the Ejection Tray with an Allen key.

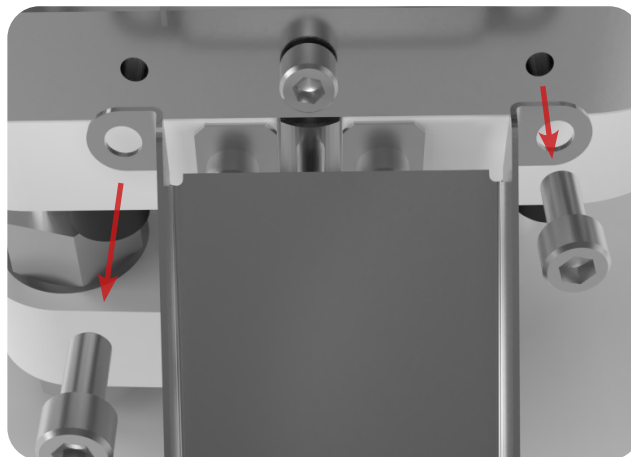

4. Remove the Lower Drift Pin Assembly Locking Bar with an Allen key.

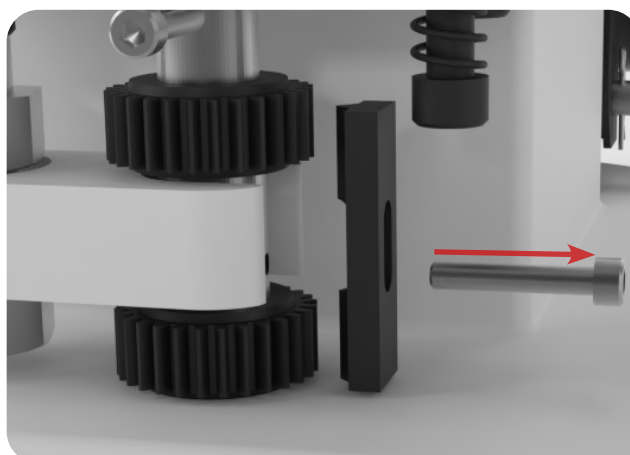

5. Rotate the Lower Cog in the Lower Drift Pin Assembly by hand.

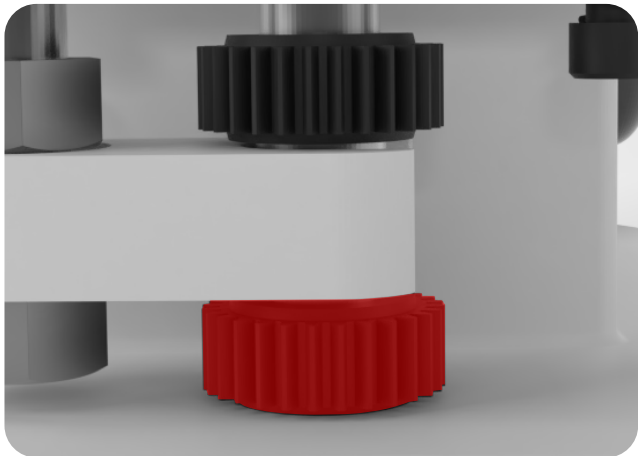

5.1 Note: To increase the tablet weight, turn counterclockwise. To decrease the tablet weight, turn clockwise.

6. Replace the bar in the Lower Drift Pin Assembly Locking Bar with an Allen key.

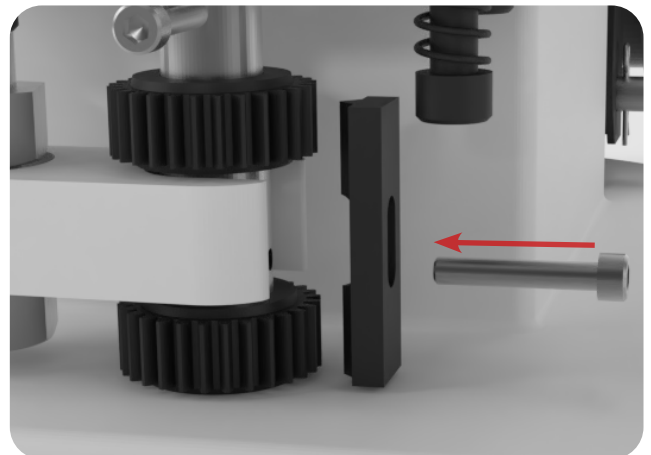

6.1 Note: Ensure that the Lower Drift Pin Assembly Locking Bar is situated vertically.

7. Produce a test tablet to make sure the weight is correct.

8. Reattach the Ejection Tray to the TDP 5®.

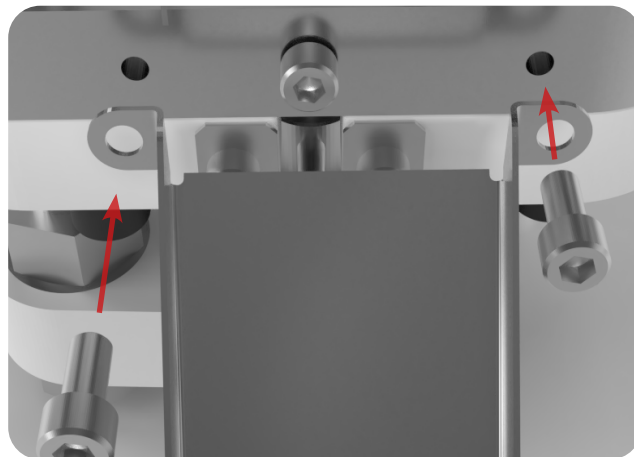

## Punch Pressure

Sometimes tablets come out too soft and will crumble easily, which happens often after increasing the fill depth. Or, the machine can jam and will not be able to turn over. To correct this, the punch pressure needs to be adjusted in order to increase the tablet's firmness/de-jam the machine.

### Tools and Materials Needed

- Set of metric Allen keys with ball ends
- 24 mm wrenches (2)
- Disposable latex/rubber gloves (for food grade products and to protect hands from grease)
- Hairnet and/or beard net (food grade products only)
- Sterile shoe covers (food grade products only)



**WARNING:** To prevent any potential personal injury, unplug the TDP 5<sup>®</sup> from the electrical outlet.

**CAUTION:** Overtightening can damage the Tooling and/or Boot.

### Instructions

Note: Wear latex/rubber gloves (and appropriate food grade attire if applicable) during this process.

1. Produce a test tablet to determine how the Tooling should be adjusted.
2. Remove the Ejection Tray with an Allen key.

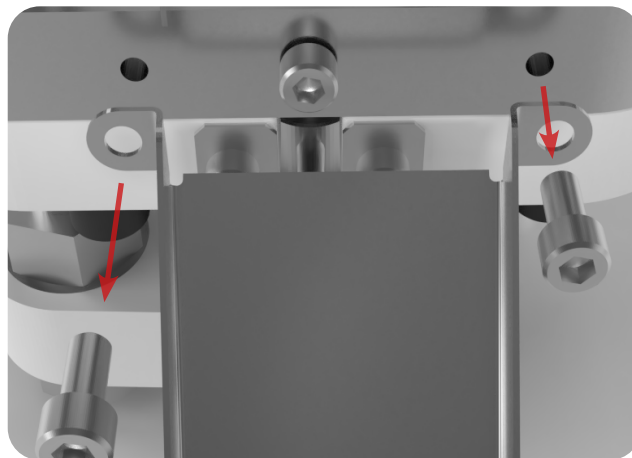

3. Remove any excess powder from the Base Plate.

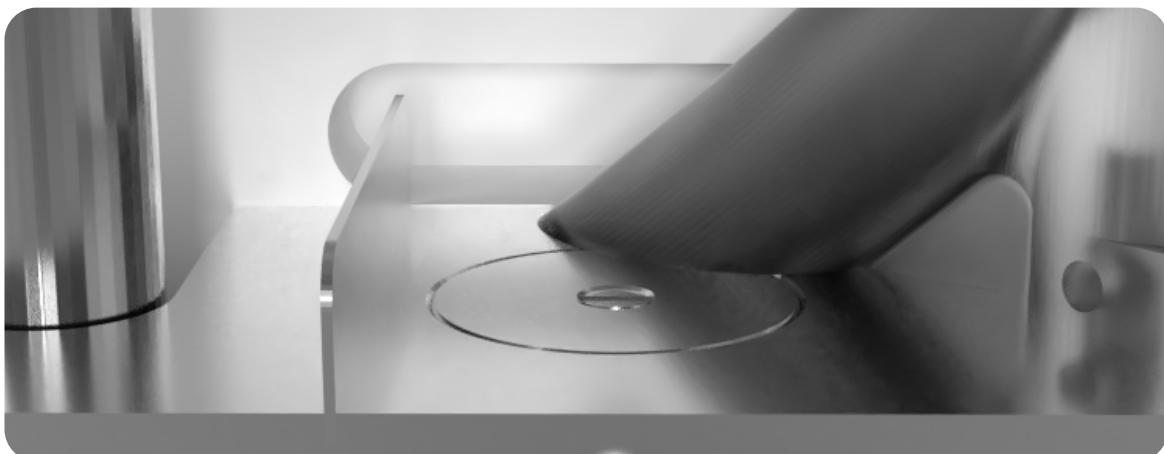

4. Turn the Hand Wheel until the Upper Punch is raised.

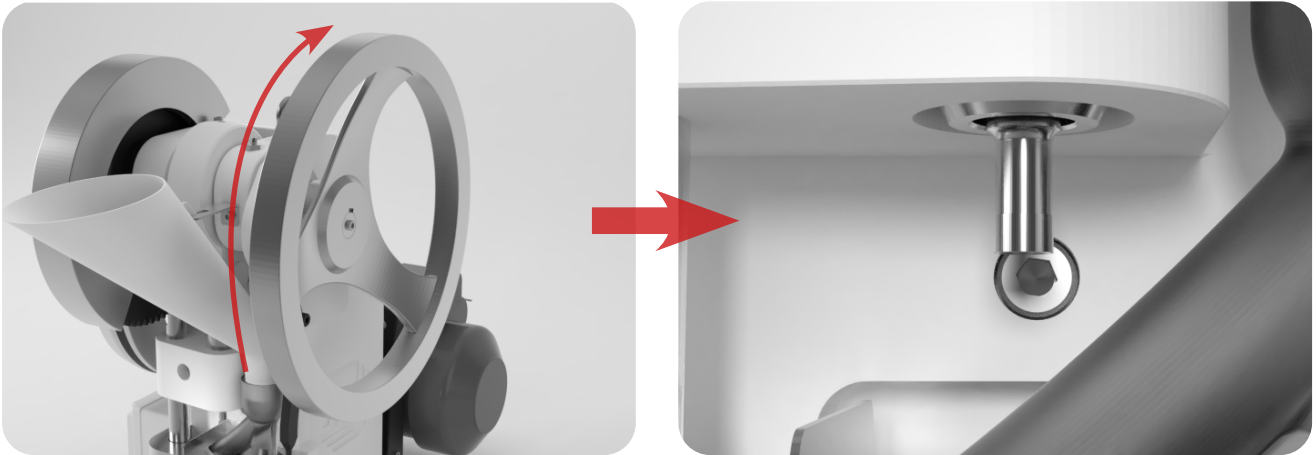

5. Loosen the Upper Drift Pin Assembly Locking Nut with a wrench while keeping the Upper Drift Pin Assembly in place with another wrench.

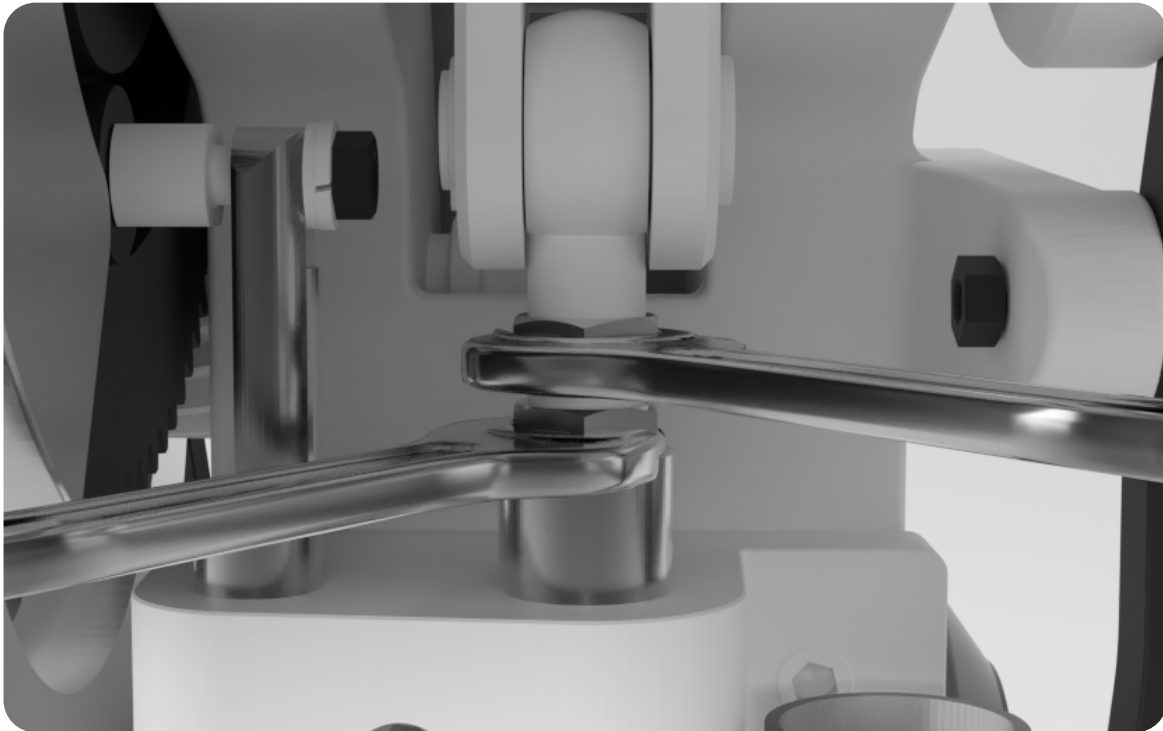

6. Turn the Hand Wheel until the Upper Drift Pin Assembly is exposed.
7. Rotate the Upper Drift Pin Assembly with a wrench or by hand.

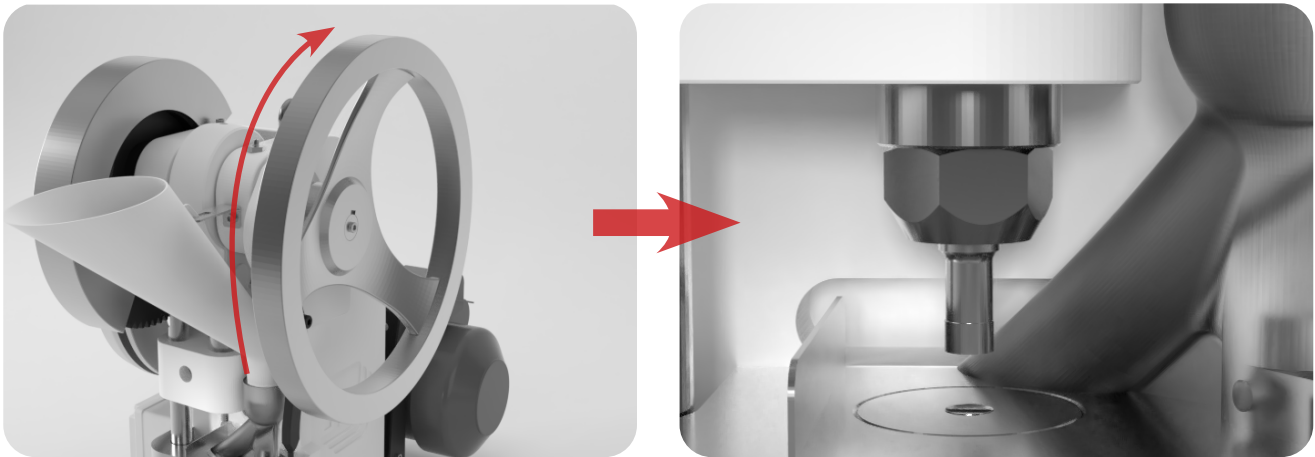

7.1 Note: To increase the pressure and harden the tablet, turn clockwise. To decrease the pressure and soften the tablet, turn counterclockwise.

8. Tighten the Upper Drift Pin Assembly Locking Nut with a wrench.
9. Reattach the Ejection Tray with an Allen key.

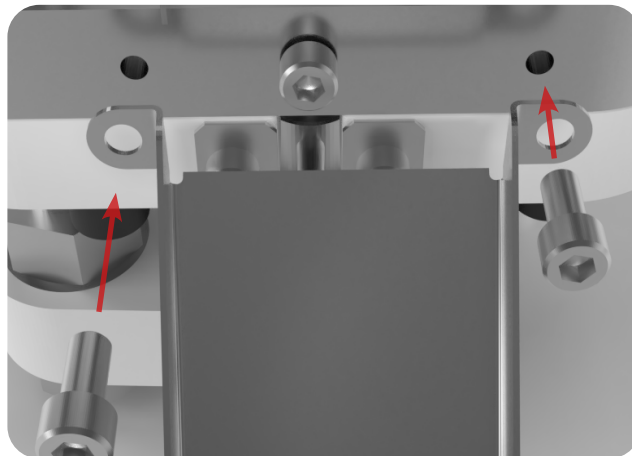

# Maintenance

To ensure that the TDP 5<sup>®</sup> will have a long operational life, maintenance is essential. This section includes methods for replacing parts, troubleshooting solutions, and how often to grease and clean your machines to keep its performance optimal.

## General Maintenance Prescriptions

- Use the maintenance checklist (found in the Appendix) before, during, and after machine operation.
- Make sure all grease points are maintained and regularly lubricated.
- Use an appropriate amount of lubricant. Excess grease can drip into the tablets as they are formed.
- Before reassembling the machine after cleaning, make sure that the parts are dried and oiled.
- Constantly check for any loose nuts and/or screws before, during, and after machine operation.
- If the machine is not used for more than a week, place the Tooling in an airtight container and cover in lubricant.

## Lubrication

Regularly greasing your machine is vital to prolonging its operational life. Parts that are not greased properly can make the machine seize up and cause major problems later. LFA recommends maintaining a lubrication schedule for your TDP 5<sup>®</sup>, which can be found in this section.

### Tools and Materials Needed

- Grease gun
- Lubricant/grease (food grade if machine has contact with the food or drug product)
- Set of metric Allen keys with ball ends
- Disposable latex/rubber gloves (for food grade products and to protect hands from grease)
- Hairnet and/or beard net (food grade products only)
- Sterile shoe covers (food grade products only)



**WARNING:** To prevent any potential personal injury, unplug the TDP 5<sup>®</sup> from the electrical outlet.

### Instructions (continued on next page)

Note: Wear latex/rubber gloves (and appropriate food grade attire if applicable) during this process.



1. Rub a finger's worth of grease on the Boot Timing Cam's side.  
1.1 Note: Be sure to lubricate the Boot Timing Cam Runner.

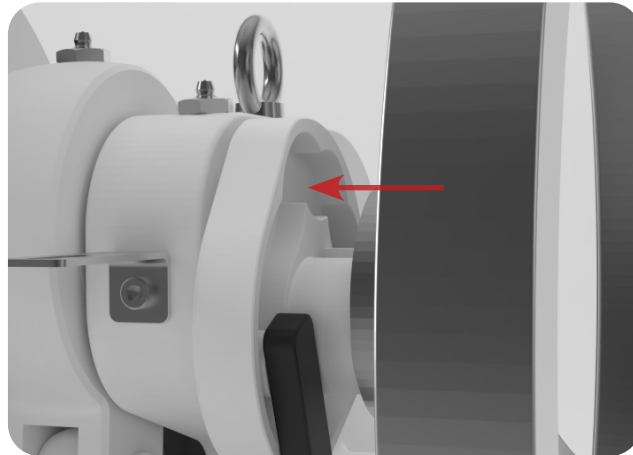

2. Lubricate the Eccentric Sheave Strap's Grease Nipple with the grease gun.  
2.1 Note: Rotate the Hand Wheel during this to ensure grease gets in between the Eccentric Sheave and the Eccentric Sheave Strap.

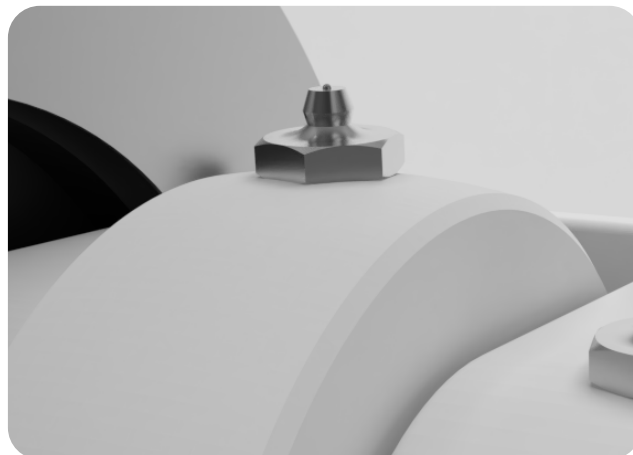

3. Lubricate the Cam Drive Cog and Lower Drift Pin Assembly Timing Rod Runner Bolt.

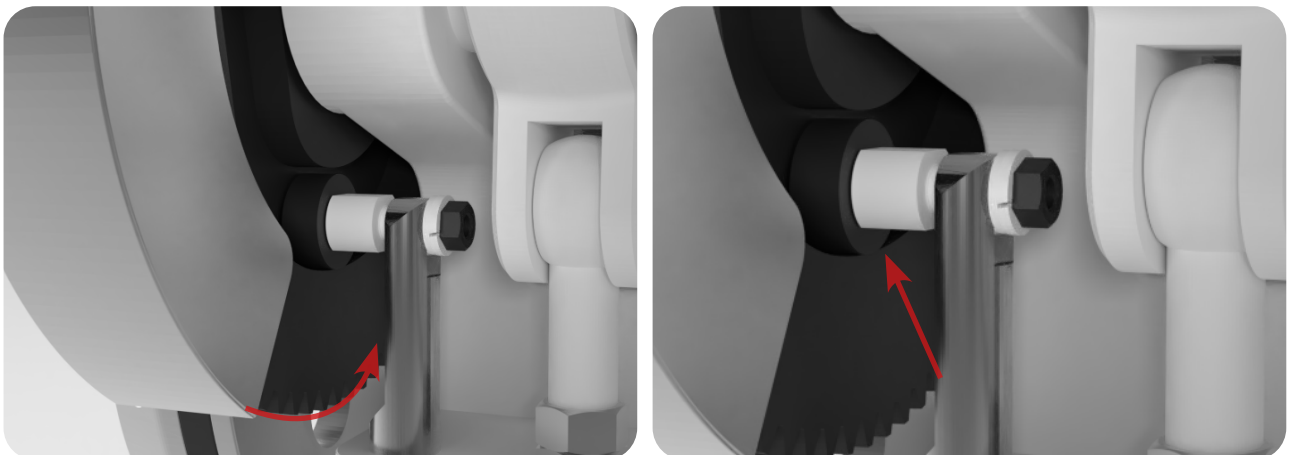

4. Lubricate the Grease Nipple nearest to the Boot Timing Cam.





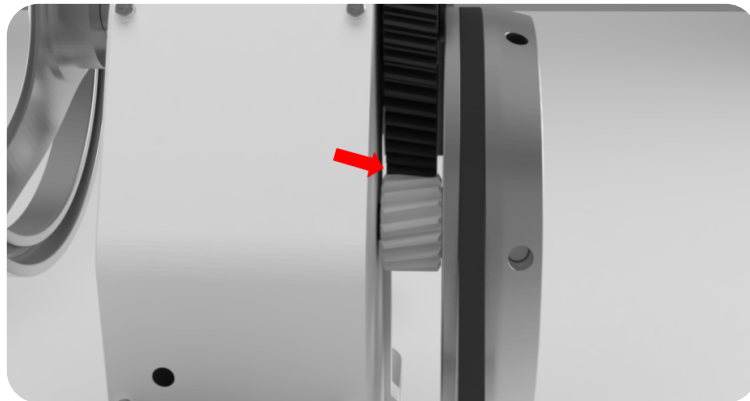

5. Lubricate the Pinion Gear.

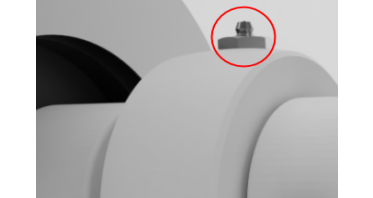
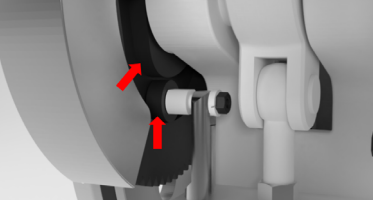

## Lubrication Schedule

LFA recommends the following TDP 5<sup>®</sup> parts to be lubricated according to the following frequency:

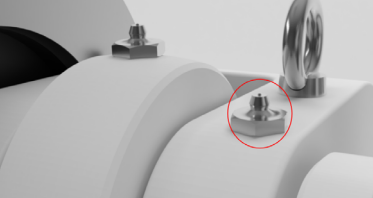
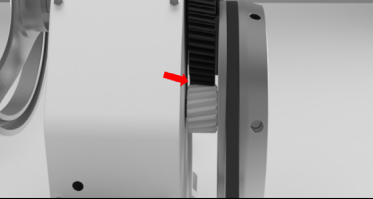
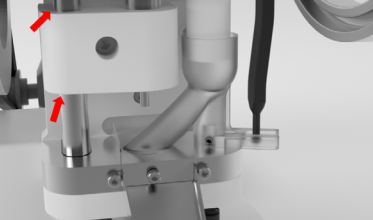
Part	Location	Image	Frequency	Type of Lubricant
Tooling heads	The heads of the Upper Punch and Lower Punch		Visually inspect and apply when dry	Assembly paste
Tooling (after cleaning)	Storage container		Apply after cleaning	Mineral oil
Eccentric Sheave Strap	The topmost Grease Nipple		Apply (a) after every 5000 tablets, (b) after a deep clean, or (c) when the press has not been used for an extended period of time	NLGI Grade 2
Cam Drive Cog	Cam track and Lower Drift Pin Assembly Timing Rod Runner Bolt		Apply (a) after every 5000 tablets, (b) after a deep clean, or (c) when the press has not been used for an extended period of time	NLGI Grade 2
Boot Timing Cam	Cam track and top of Boot Timing Bar		Apply (a) after every 5000 tablets, (b) after a deep clean, or (c) when the press has not been used for an extended period of time	NLGI Grade 2
Top Cam Drive Shaft	Grease Nipple nearest to Boot Timing Cam		Apply (a) after every 5000 tablets, (b) after a deep clean, or (c) when the press has not been used for an extended period of time	NLGI Grade 2
Pinion Gear	Between the Electrical Drive Flywheel and Cam Drive Cog		Apply (a) after every 5000 tablets, (b) after a deep clean, or (c) when the press has not been used for an extended period of time	NLGI Grade 2
Lower Drift Pin Assembly Timing Rod	The points at which the Lower Drift Pin Assembly, Upper Drift Pin Assembly Mounting Block, and TDP 5 <sup>®</sup> Base meet.		Apply a small amount whenever the press will be left unattended for an extended period of time	Mineral oil

## Dismantling for Repair and Replacement

Eventually due to wear and tear, some parts of the TDP 5<sup>®</sup> will need to be removed for repair and replacement. To prevent any delays in your tablet production, it is best practice to keep extra parts just in case.

To buy a TDP 5<sup>®</sup> part replacement, simply go to <https://www.lfatabletpresses.com/products/pill-press-machine-spare-parts/tdp-5-parts>

### Warranty

To access LFA's warranty policy, go to <https://www.lfatabletpresses.com/warranty>  
If your part is eligible for warranty, have your part's serial number on hand and please contact LFA:

#### UK

##### Phone

+44 01869 250234

##### Email

[support.uk@lfamachines.com](mailto:support.uk@lfamachines.com)

#### USA

##### Phone

+1 (682) 312-0309

##### Email

[support.usa@lfamachines.com](mailto:support.usa@lfamachines.com)

#### Taiwan

##### Phone

+886 422031790

##### Email

[support.asia@lfamachines.com](mailto:support.asia@lfamachines.com)



**WARNING:** To prevent any potential personal injury, ALWAYS unplug the TDP 5<sup>®</sup> from the electrical outlet when replacing parts.

## Wear Parts and Causes of Damage

Wear Part	Cause of Damage
Tooling	The Tooling can become chipped or broken. Lead times for a new set of Tooling can take as long as 6-8 weeks, so LFA recommends having a spare set or two.
Boot	The TDP 5 <sup>®</sup> Boot is formed from a toughened plastic. This part can become trapped between the Die Bore and the Upper Punch, which usually results from user error.

## Tooling

If you want to change the shape and diameter of the tablet, or if the Upper Punch, Lower Punch, and/or Die you currently have is damaged, it is necessary to change the Tooling.

To buy new Tooling from LFA, simply go to <https://www.lfatabletpresses.com/products/tablet-press-tooling>

To watch a video of a TDP 5<sup>®</sup> Tooling change, go to <https://www.lfatabletpresses.com/videos/how-to-change-tdp-punch-die-tooling>

### Tools and Materials Needed

- Set of metric Allen keys with ball ends
- 24 mm wrenches (2)
- Tooling/die set (Upper Punch, Die, and Lower Punch)
- Grippers or pliers
- Hammer (if Die is difficult to remove)
- Disposable latex/rubber gloves (for food grade products and to protect hands from grease)
- Hairnet and/or beard net (food grade products only)
- Sterile shoe covers (food grade products only)



**WARNING:** To prevent any potential personal injury, ALWAYS unplug the TDP 5<sup>®</sup> from the electrical outlet when replacing parts.

### Instructions

Note: Wear latex/rubber gloves (and appropriate food grade attire if applicable) during this process.

#### Remove the Tooling

1. Remove the Hopper carefully and catch any powder still inside of it.
2. Remove the Ejection Tray with an Allen key.

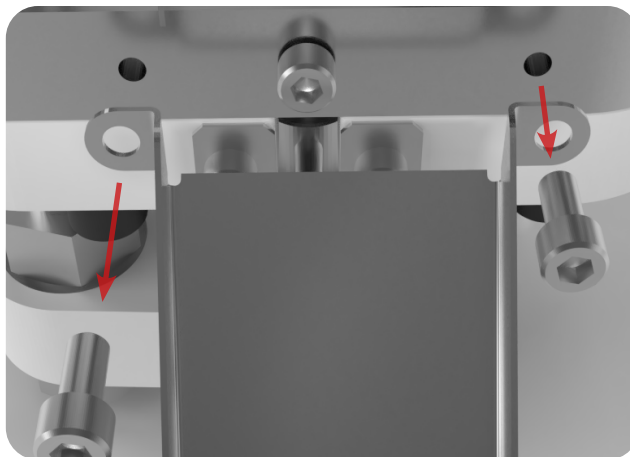

3. Loosen the Boot's set screw with an Allen key.

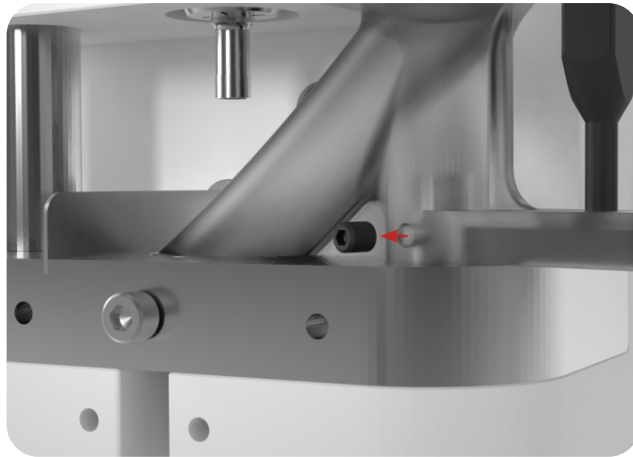

4. Remove the Boot Bolt and Spring underneath the Boot with an Allen key.

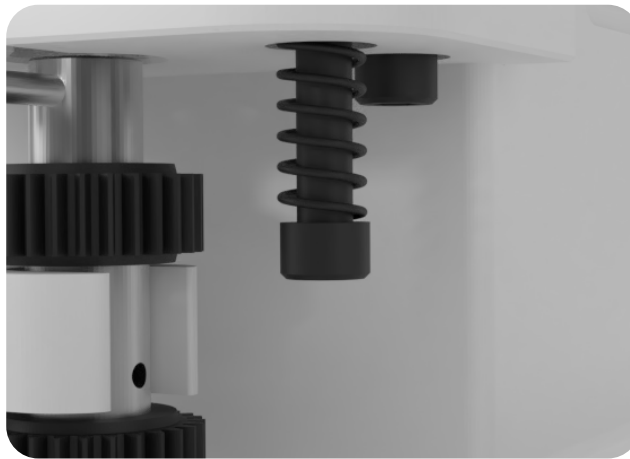

5. Take off the Boot carefully and remove any powder still inside it.

6. Loosen the bolts underneath the Base Plate with an Allen key.

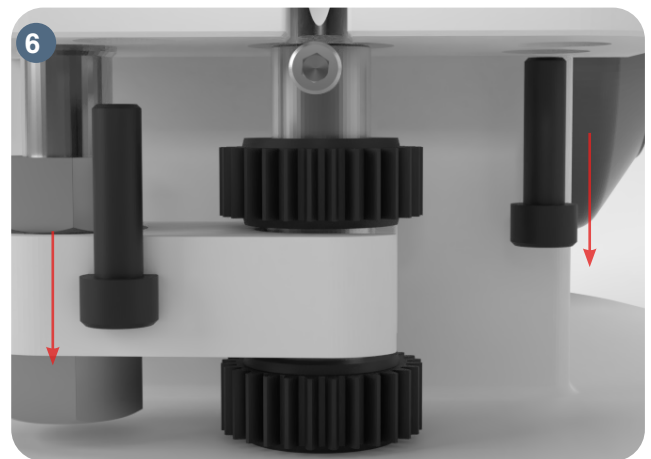
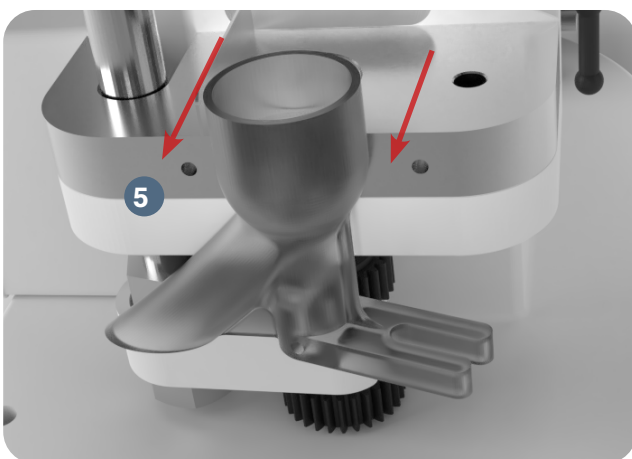

7. Turn the Hand Wheel until the Upper Drift Pin Assembly is lowered.
8. Loosen the Upper Punch Die Locking Nut with a wrench while keeping the Upper Punch Drift Assembly in place with another wrench.
9. Remove the Upper Punch by hand.

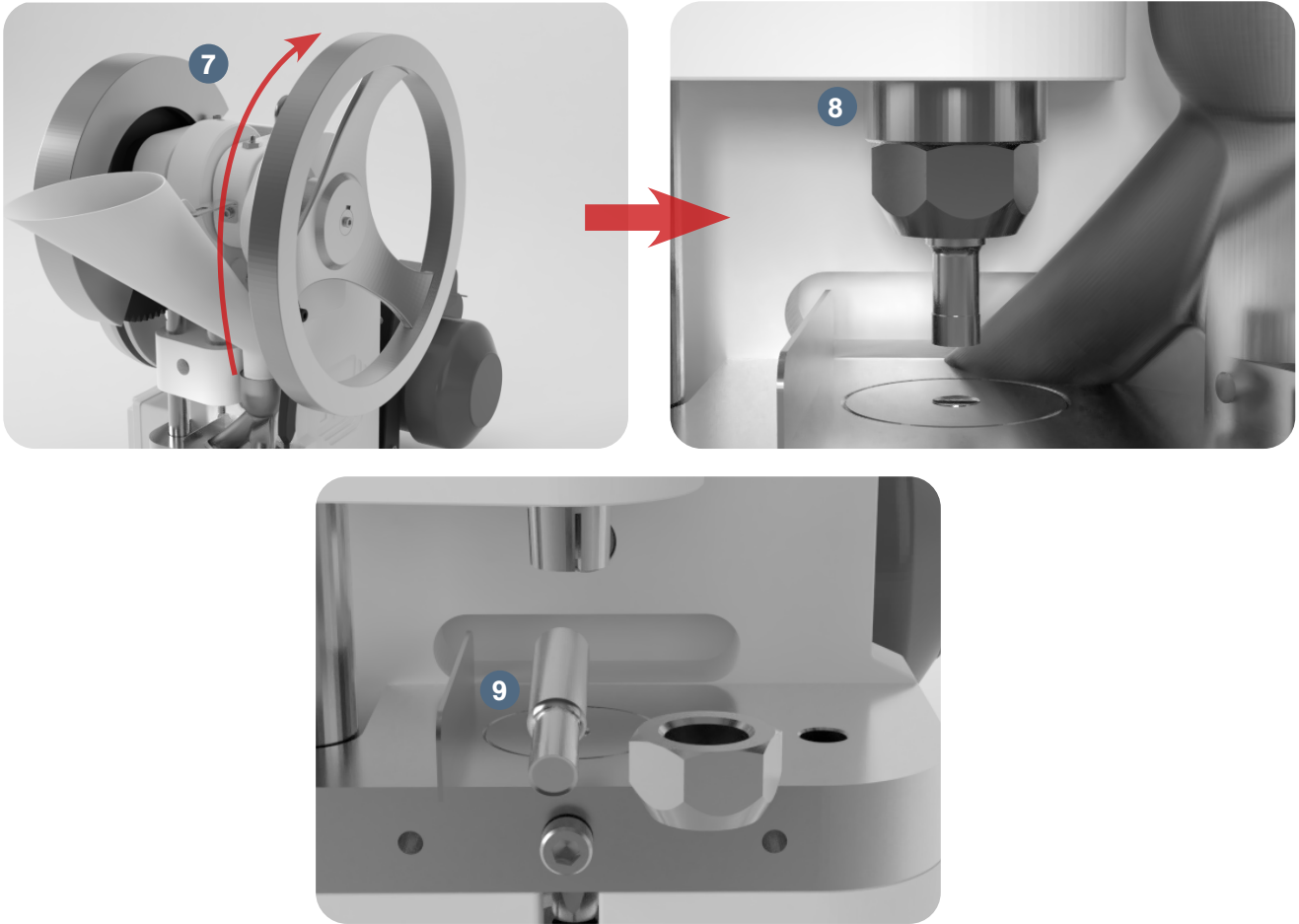

9.1 Note: If you cannot remove by hand, carefully use grippers or pliers.

10. Remove the Base Plate with the Die still inside it.
11. Remove the set screw that locks the Die with an Allen key.
12. Take out the Die from the middle of the Base Plate.
  - 12.1 Lightly tap the Die with a hammer if it is difficult to remove.

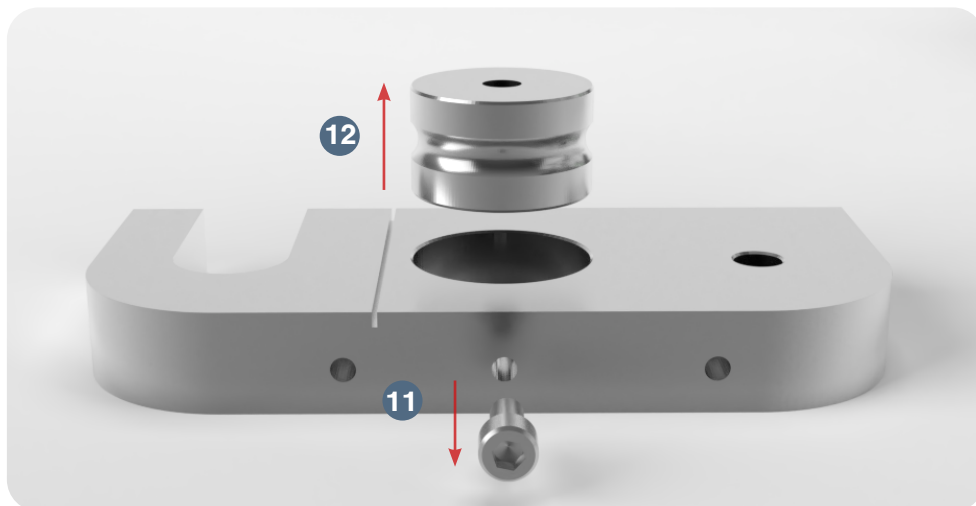

- 13. Remove the bolt that locks the Lower Punch with an Allen key.
- 14. Remove the Lower Punch by hand.

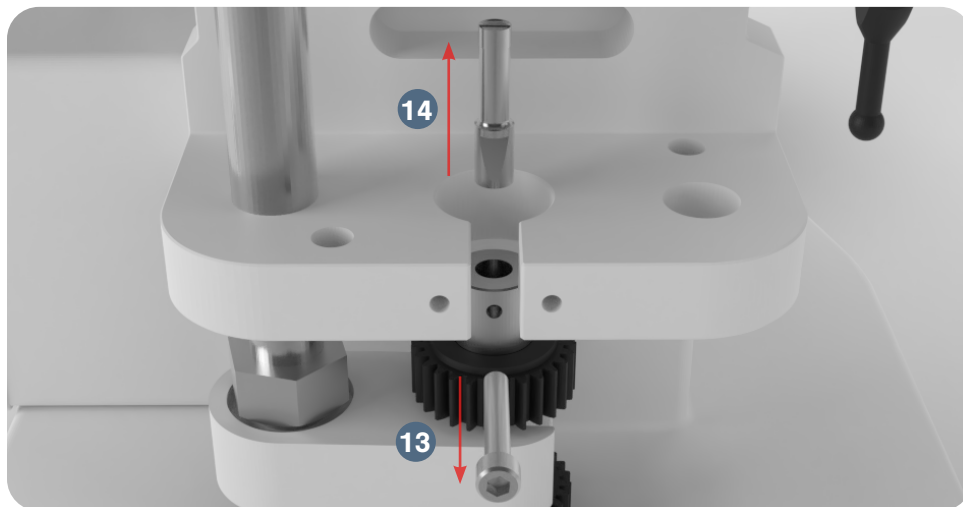

14.1 Note: If you cannot remove by hand, carefully use grippers or pliers.

Note: To help ensure that the Die is inserted correctly, LFA recommends using an Insertion Ring. You can order the Die Seat Cleaner and Insertion Ring on our website at <https://www.lfatabletpresses.com/die-seat-cleaner-insertion-ring>



### Replace the Tooling

- 15. Insert the new Lower Punch into the Lower Drift Pin Assembly.
- 16. Reinsert the bolt that locks the Lower Punch with an Allen key.

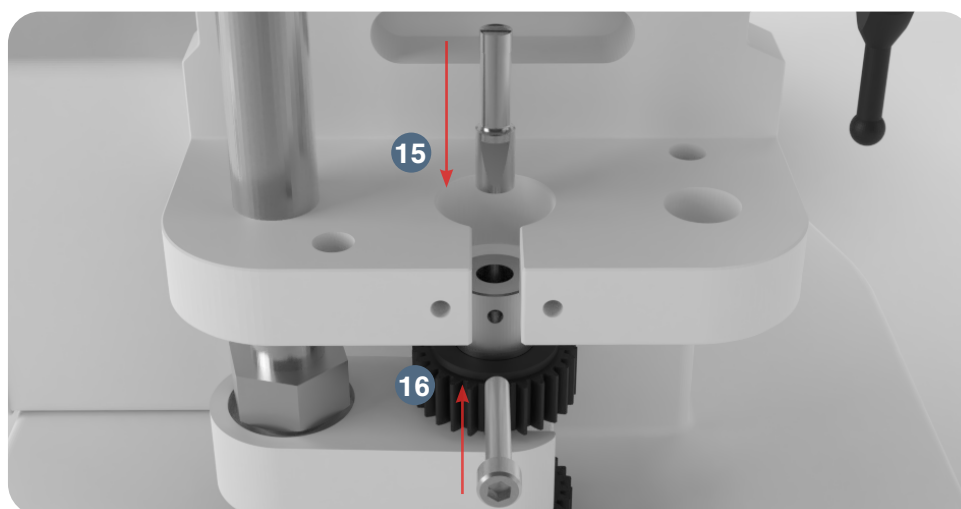

16.1 Note: Make sure that the Lower Punch's “keyed” section is facing forward.



17. Place the Base Plate onto the TDP 5® Base.
18. Insert the new Die into the middle of the Base Plate.
19. Reinsert the set screw that locks the Die with an Allen key.
  - 19.1 Note: Make sure the set screw is not fully tightened.

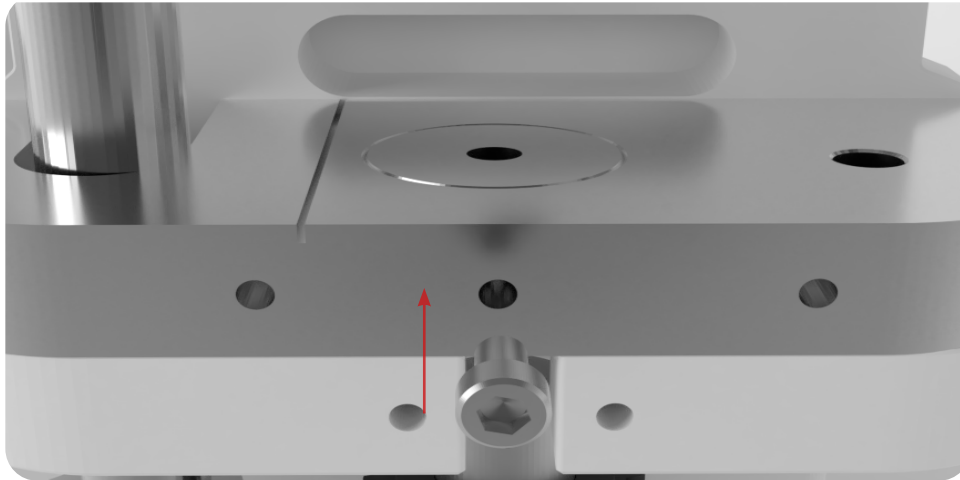

20. Insert the new Upper Punch into the Upper Drift Pin Assembly.
21. Tighten the Upper Punch Locking Nut onto the Upper Drift Pin Assembly with a wrench.

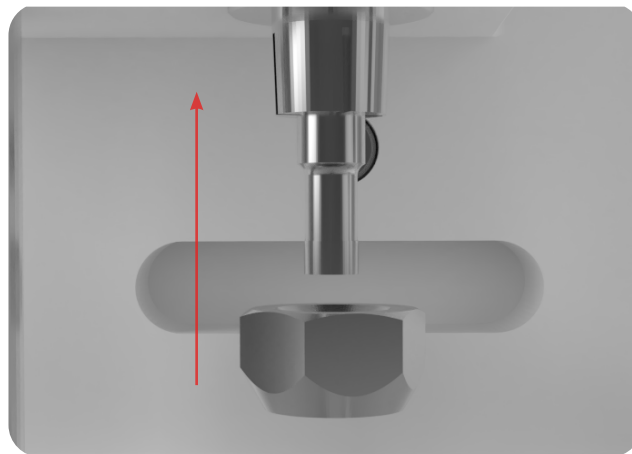

22. Rotate the Hand Wheel and carefully lower the Upper Punch into the Die.
  - 22.1 Note: Rotate the Hand Wheel to see that the Upper Punch smoothly enters the Die bore and that the Die is seated firmly in the Upper Drift Pin Assembly. To watch a video on proper Base Plate alignment, go to <https://www.ifatabletpresses.com/videos/how-to-align-a-baseplate-on-a-tdp-5>

23. Reinsert the Base Plate's bolts.

23.1 Note: The Die's set screw can be fully tightened now.

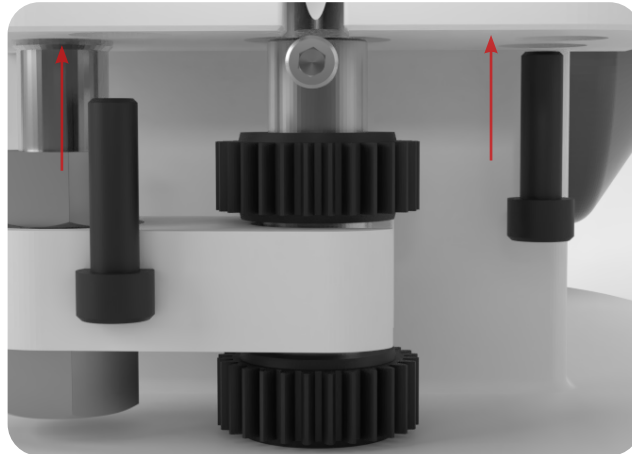

24. Position the Boot back on the Base Plate.

25. Insert the Boot Timing Bar's end in the Boot

26. Resecure the Boot Bolt and Spring underneath the Boot with an Allen key.

27. Tighten the Boot's set screw with an Allen key.

28. Reattach the Ejection Tray with an Allen key.

29. Reinsert the Hopper.

30. Turn the Hand Wheel for one rotation of the Top Cam Drive Shaft to ensure that the machine runs smoothly before plugging it in and turning it on.

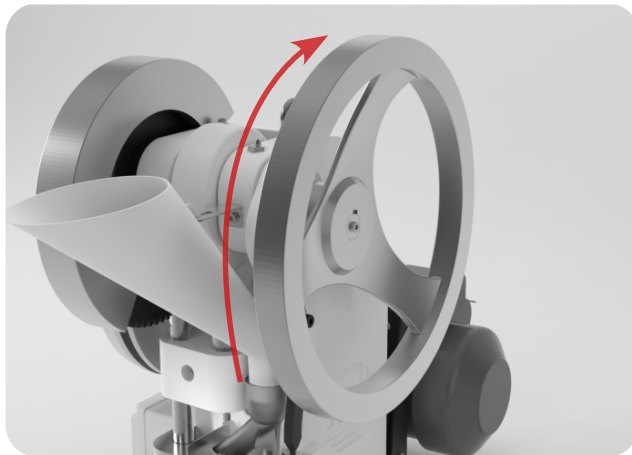

## Boot Timing Bar

This part can become warped from collision, and it is critical to the TDP 5<sup>®</sup>'s operation. If you need to replace your TDP 5<sup>®</sup>'s Boot Timing Bar, the process is quite simple.

### Tools and Materials Needed

- Set of metric Allen keys with ball ends
- 13 mm wrench
- New Boot Timing Bar part
- Disposable latex/rubber gloves (for food grade products and to protect hands from grease)
- Hairnet and/or beard net (food grade products only)
- Sterile shoe covers (food grade products only)



**WARNING:** To prevent any potential personal injury, ALWAYS unplug the TDP 5<sup>®</sup> from the electrical outlet when replacing parts.

### Instructions

Note: Wear latex/rubber gloves (and appropriate food grade attire if applicable) during this process.

#### Remove the Boot Timing Bar

1. Remove the Hopper carefully and catch any powder still inside of it.
2. Loosen the Boot Timing Bar bolt's nuts with a wrench.
3. Loosen the Boot Timing Bar bolt with an Allen key.
4. Remove the Boot Timing Bar's end from the Boot.

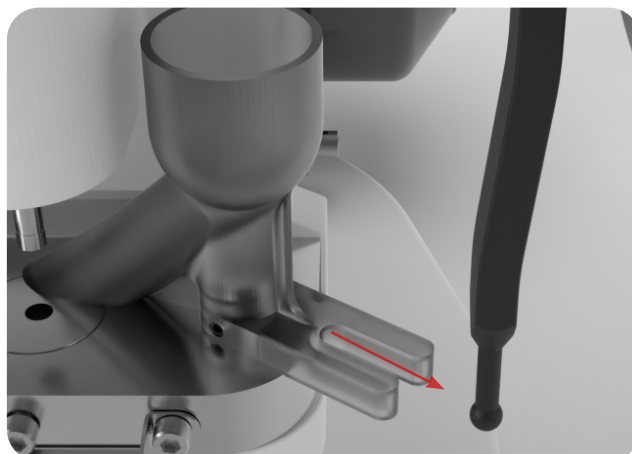
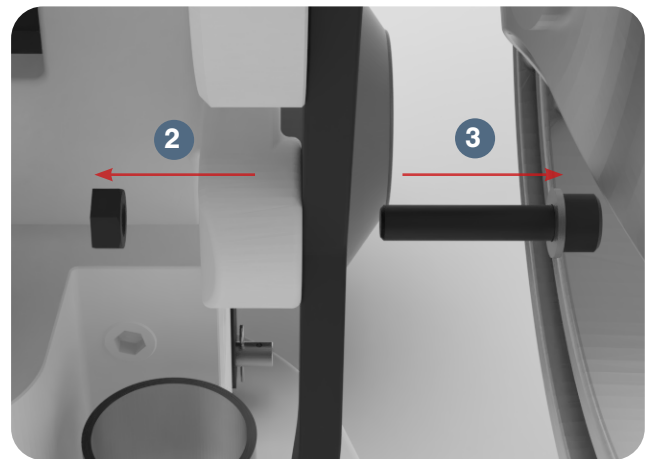
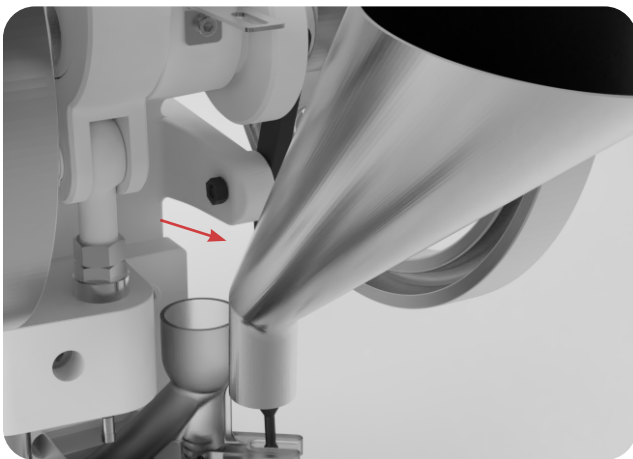

5. Remove the top part of Boot Timing Bar from the Boot Timing Cam.

5.1 Note: To make removal easier, turn the Handle to rotate the Boot Timing Cam so you can easily access the Boot Timing Bar.

6. Remove the Boot Timing Cam Runner from the Boot Timing Bar by hand.

7. Remove the Boot Timing Bar from the Base Plate.

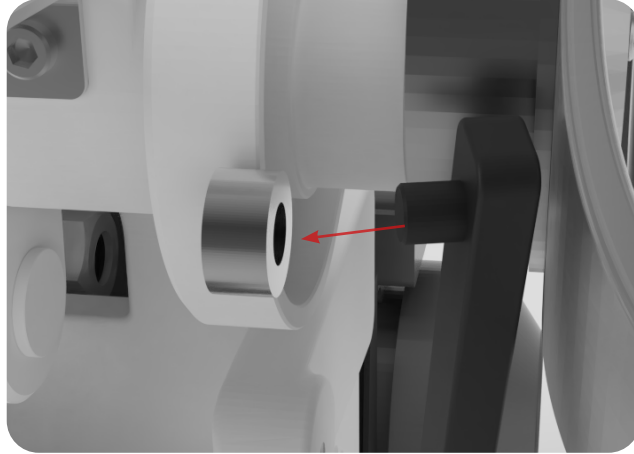

#### **Replace the Boot Timing Bar**

8. Place the Boot Timing Cam Runner on the new Boot Timing Bar.

9. Insert the new Boot Timing Bar with the runner into the side of the Boot Timing Cam.

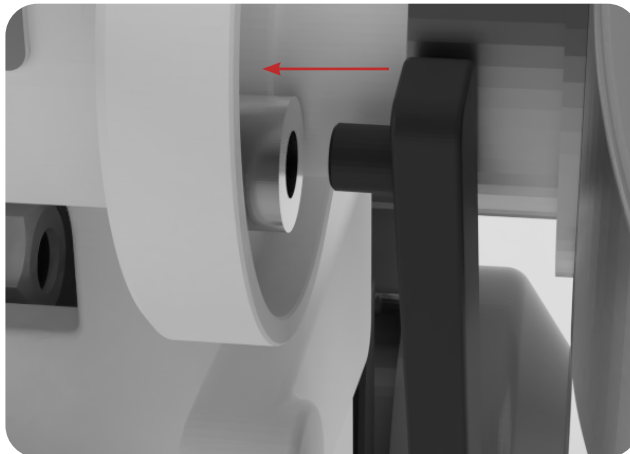

10. Insert the new Boot Timing Bar's end in the Boot
11. Tighten the Boot Timing Bar bolt with an Allen key.
12. Tighten the Boot Timing Bar bolt's nuts with a wrench.

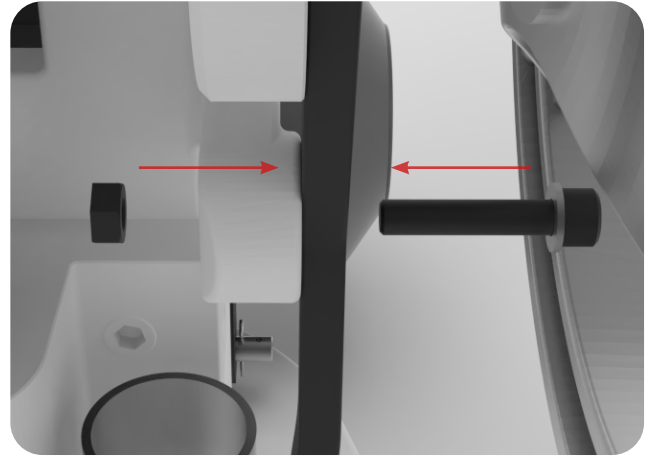
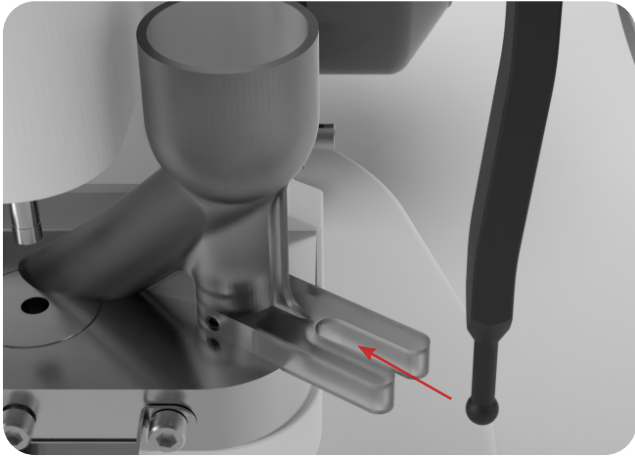

13. Reinsert the Hopper.
14. Turn the Hand Wheel for one rotation of the Top Cam Drive Shaft to ensure that the machine runs smoothly before plugging it in and turning it on.

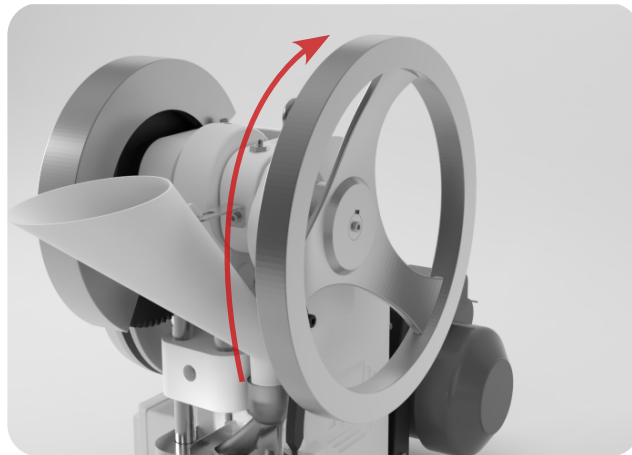

## Boot

Due to its constant movement, the Boot can wear down and prevent granular material from flowing smoothly. Replacing this part is a simple process. To watch a video of Boot removal, go to <https://www.lfatablepresses.com/videos/how-to-remove-the-boot-timing-bar-on-a-tdp-5>

### Tools and Materials Needed

- Set of metric Allen keys with ball ends
- New Boot part
- Disposable latex/rubber gloves (for food grade products and to protect hands from grease)
- Hairnet and/or beard net (food grade products only)
- Sterile shoe covers (food grade products only)



**WARNING:** To prevent any potential personal injury, ALWAYS unplug the TDP 5<sup>®</sup> from the electrical outlet when replacing parts.

### Instructions

Note: Wear latex/rubber gloves (and appropriate food grade attire if applicable) during this process.

#### Remove the Boot

1. Remove the Hopper carefully and catch any powder still inside of it.
2. Remove the Ejection Tray with an Allen key.

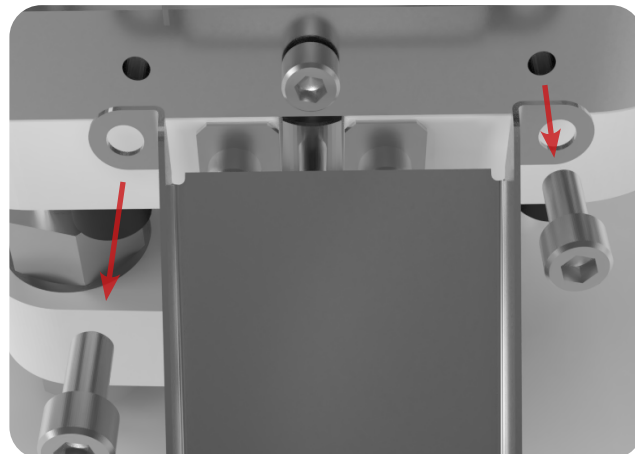

3. Loosen the Boot's set screw with an Allen key.

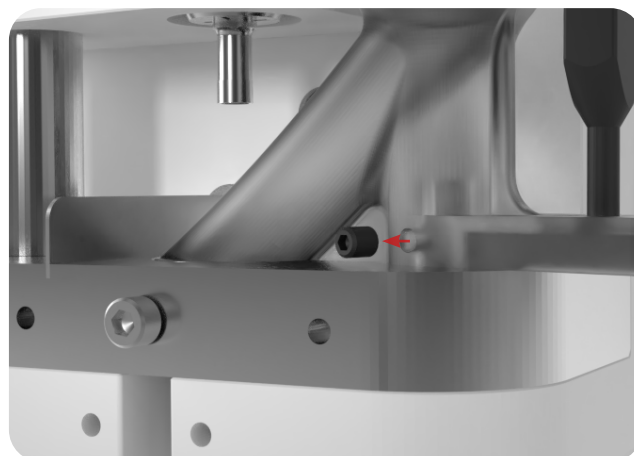

4. Remove the Boot Bolt and Spring underneath the Boot with an Allen key.

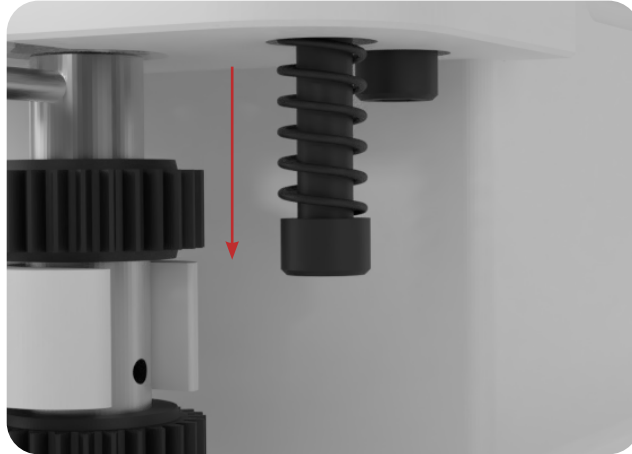

5. Take off the Boot carefully and remove any powder still inside it.

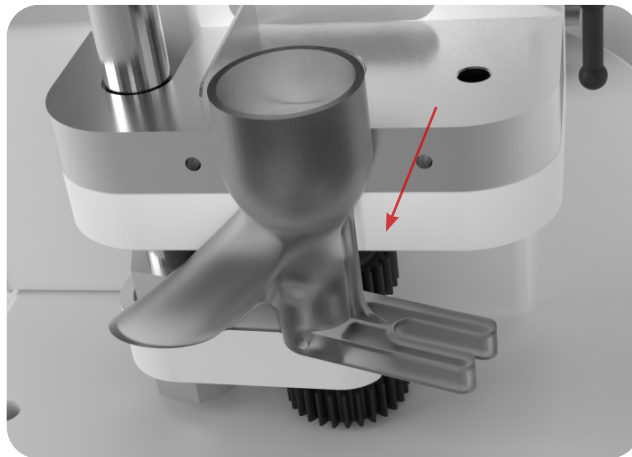

### Replace the Boot

6. Position the new Boot on the Base Plate.

7. Insert the Boot Timing Bar's end in the new Boot.

8. Resecure the Boot Bolt and Spring underneath the new Boot with an Allen key.

9. Tighten the new Boot's set screw with an Allen key.

10. Reattach the Ejection Tray with an Allen key.

11. Reinsert the Hopper.

12. Turn the Hand Wheel for one rotation of the Top Cam Drive Shaft to ensure that the machine runs smoothly before plugging it in and turning it on.

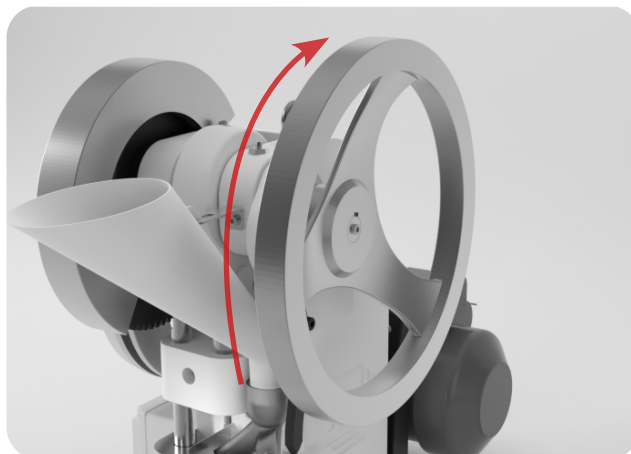

## Upper Drift Pin Assembly

The Upper Drift Pin Assembly holds the TDP 5®'s Upper Punch. Sometimes this part threads or bends, which interferes with smooth movement.

### Tools and Materials Needed

- Set of metric Allen keys with ball ends
- 24 mm wrenches (2)
- New Upper Drift Pin Assembly part
- Disposable latex/rubber gloves (for food grade products and to protect hands from grease)
- Hairnet and/or beard net (food grade products only)
- Sterile shoe covers (food grade products only)



**WARNING:** To prevent any potential personal injury, ALWAYS unplug the TDP 5® from the electrical outlet when replacing parts.

### Instructions

Note: Wear latex/rubber gloves (and appropriate food grade attire if applicable) during this process.

#### Remove the Upper Drift Pin Assembly

1. Remove the Hopper carefully and catch any powder still inside of it.
2. Remove the Ejection Tray with an Allen key.

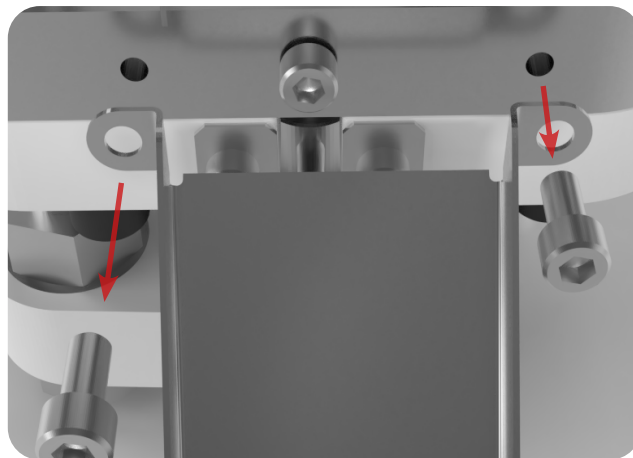



3. Loosen the Boot's set screw with an Allen key.
4. Remove the Boot Bolt and Spring underneath the Boot with an Allen key.

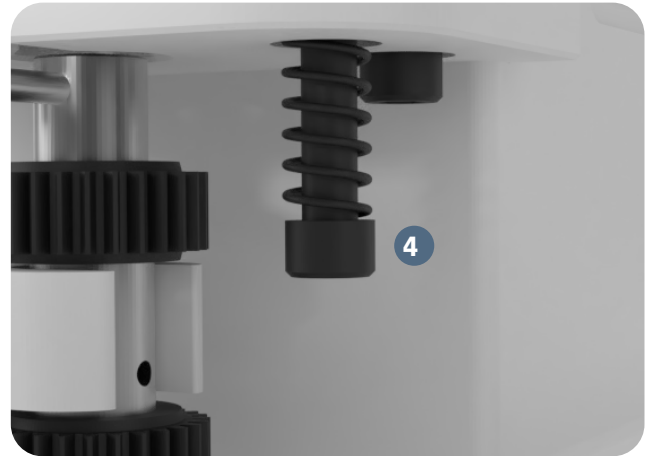
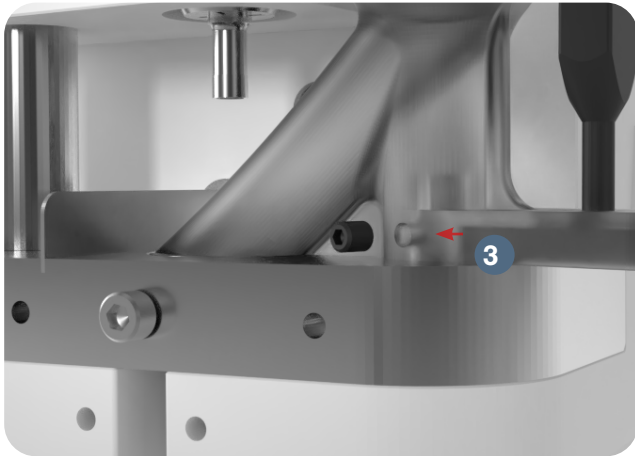

5. Take off the Boot carefully and remove any powder still inside it.
6. Loosen the bolts underneath the Base Plate with an Allen key.

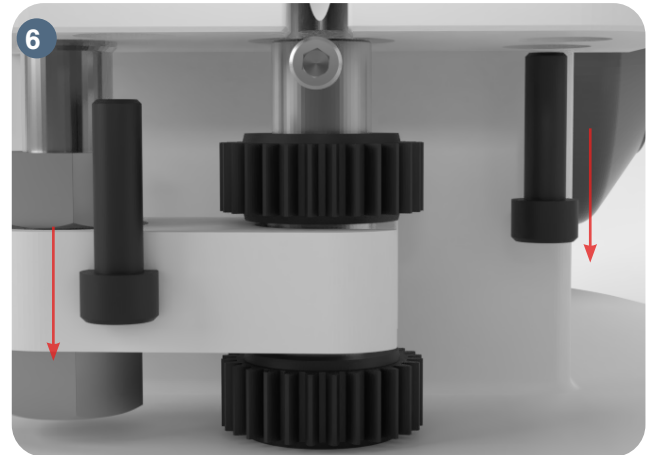
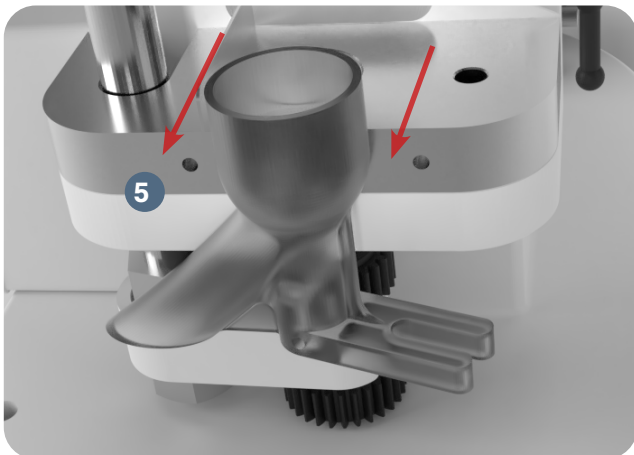

7. Turn the Hand Wheel until the Upper Drift Pin Assembly is lowered.
8. Loosen the Upper Punch Die Locking Nut with a wrench while keeping the Upper Punch Drift Assembly in place with another wrench.

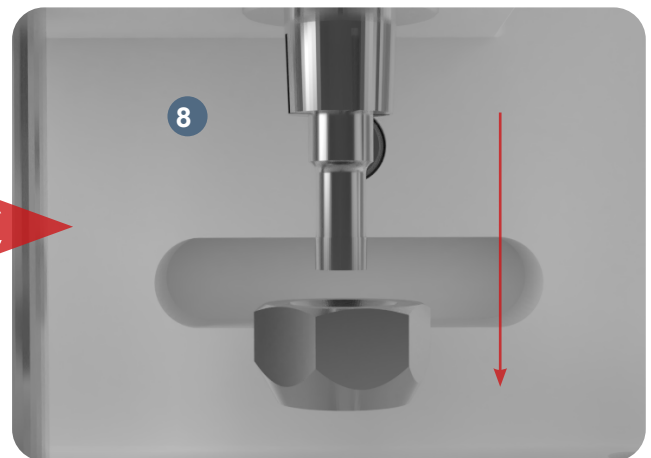
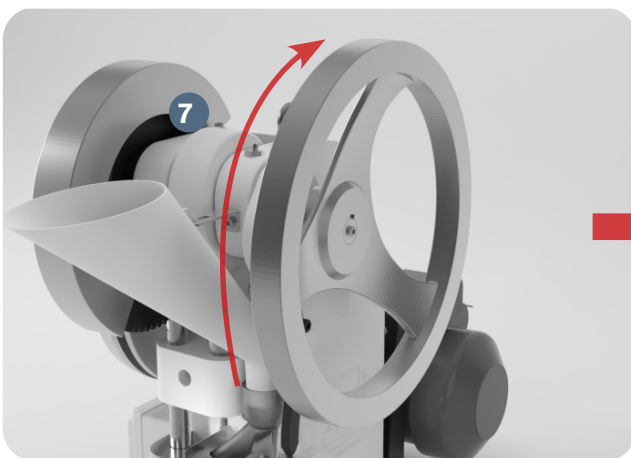

9. Remove the Upper Punch by hand.

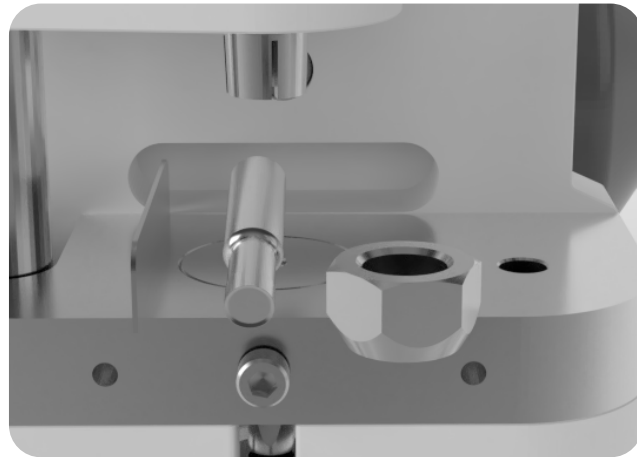

9.1 Note: If you cannot remove by hand, carefully use grippers or pliers.

10. Remove the Base Plate with the Die still inside it.

11. Remove the bolt that locks the Die with an Allen key.

12. Take out the Die from the middle of the Base Plate.

12.1 Tap the Die with a hammer if it is difficult to remove.

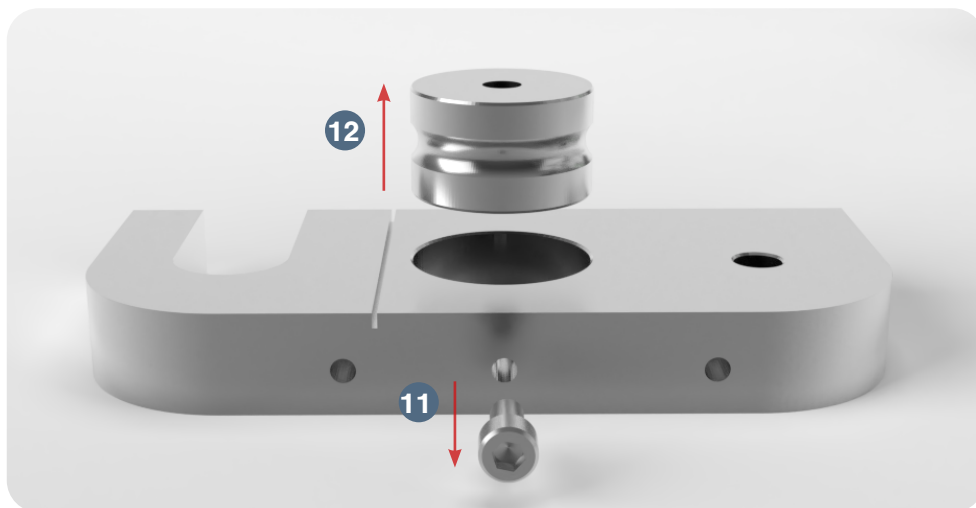

13. Remove the bolt that locks the Lower Punch with an Allen key.
14. Remove the Lower Punch by hand.

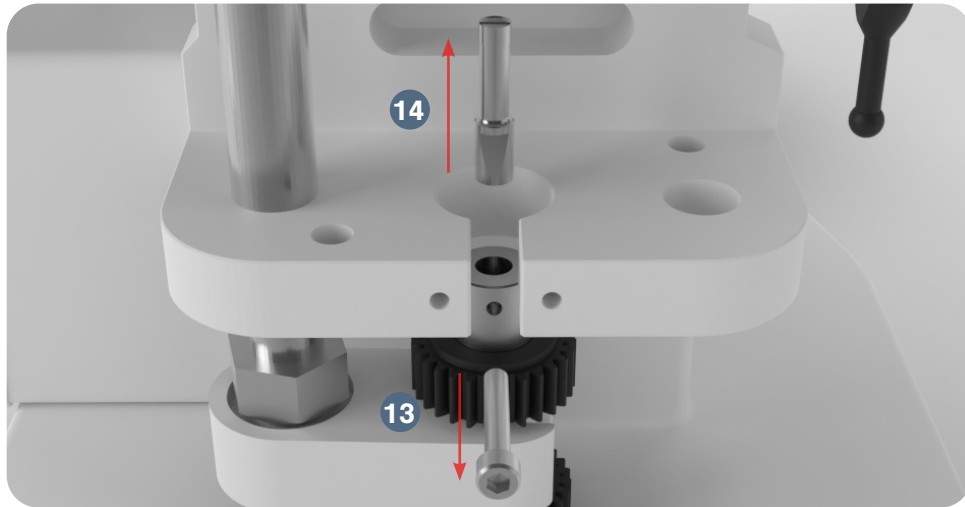

15. Loosen the Upper Drift Pin Assembly Locking Nut with a wrench.
16. Unscrew the Upper Drift Pin Assembly from the Upper Drift Pin Assembly Rod Eye and Clevis.

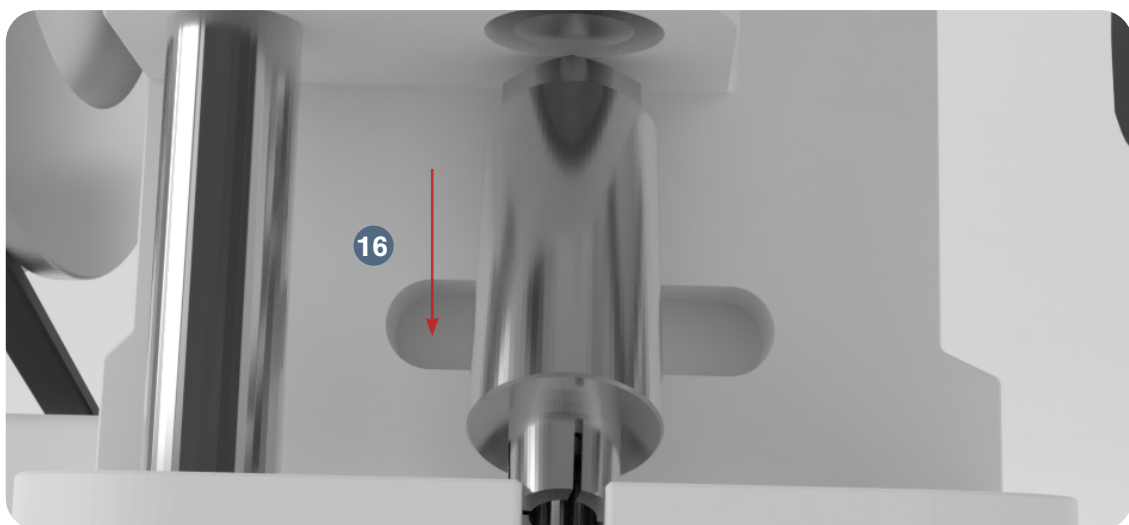
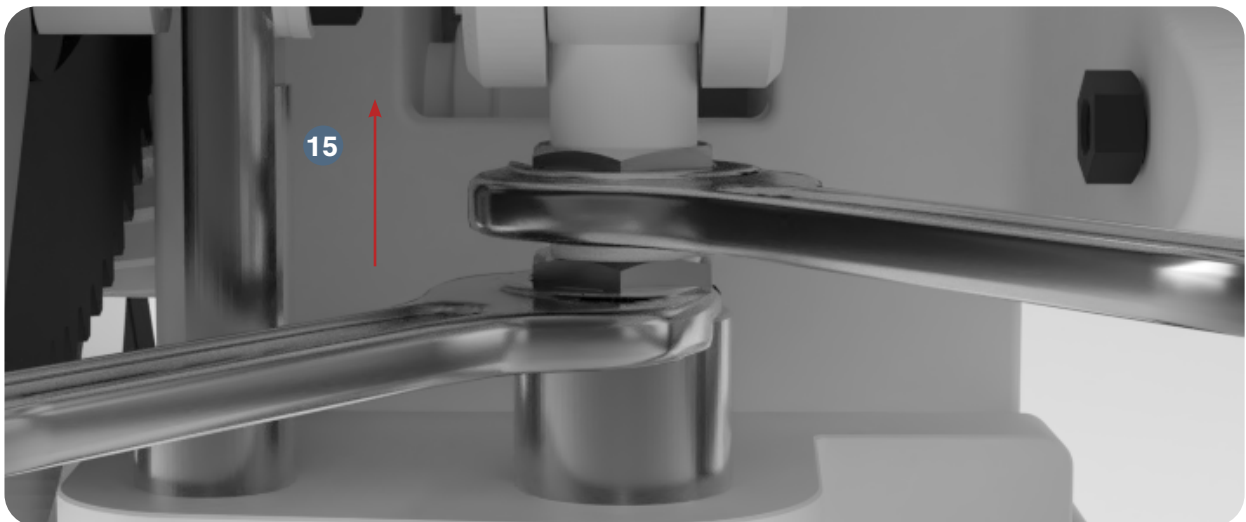

### Replace the Upper Drift Pin Assembly

17. Screw in the new Upper Drift Pin Assembly onto the Upper Drift Pin Assembly Rod Eye and Clevis.

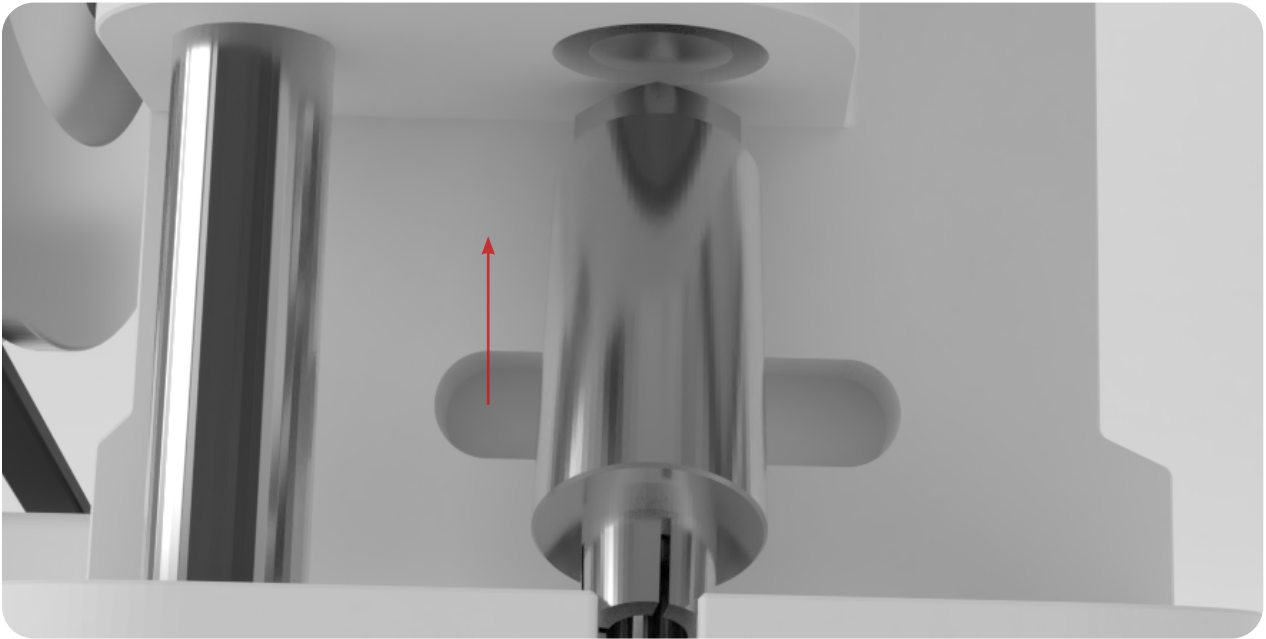

18. Tighten the Upper Drift Pin Assembly Locking Nut onto the Upper Drift Pin Assembly Rod Eye and Clevis by hand or with a wrench.

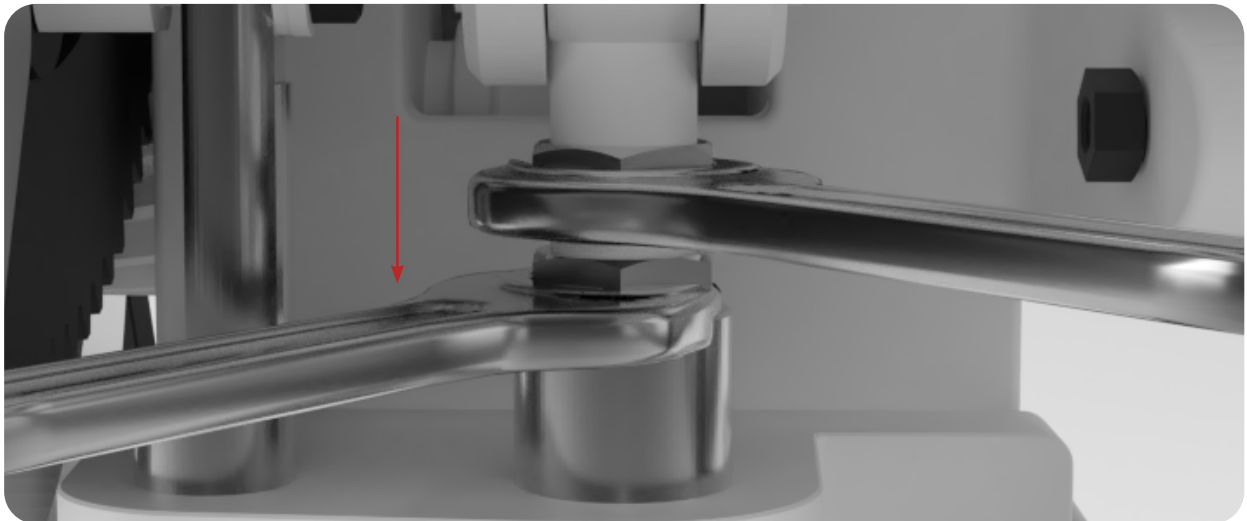

19. Reinsert the Lower Punch into the Lower Drift Pin Assembly.
20. Reinsert the bolt that locks the Lower Punch with an Allen key.

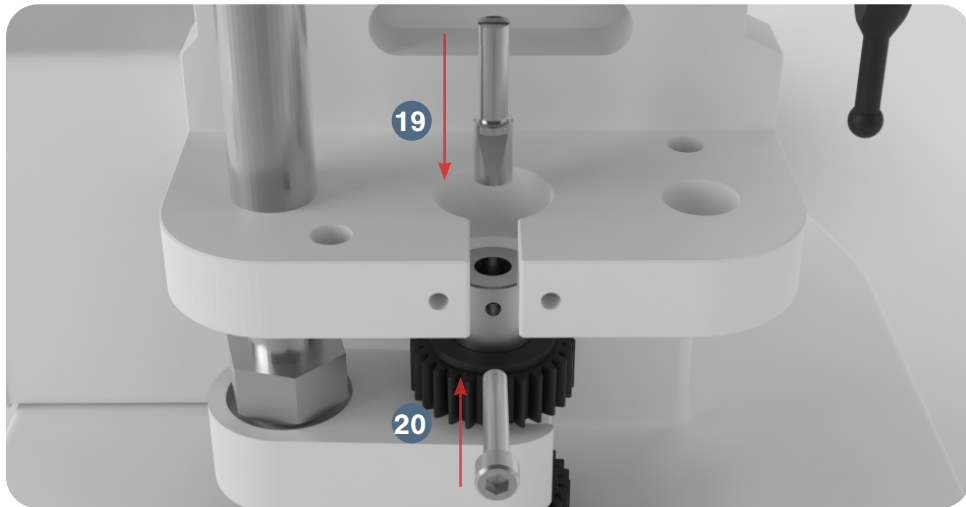

- 20.1 Note: Make sure that the Lower Punch's “keyed” section is facing forward.
21. Place the Base Plate onto the TDP 5<sup>®</sup> Base.
  22. Insert the Die into the middle of the Base Plate.
  23. Reinsert the bolt that locks the Die with an Allen key.
- 23.1 Note: Make sure the bolt is not fully tightened.

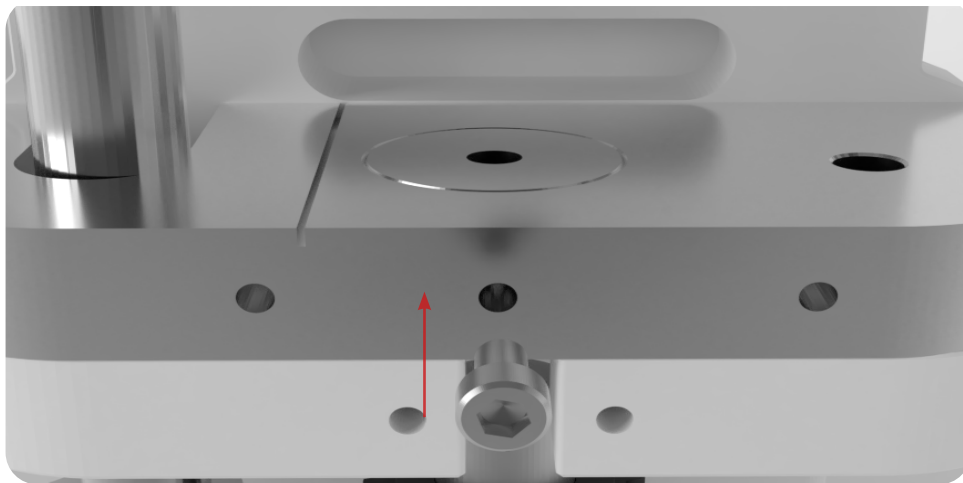

24. Insert the Upper Punch into the Upper Drift Pin Assembly.
25. Tighten the Upper Punch Die Locking Nut onto the Upper Drift Pin Assembly with a wrench.

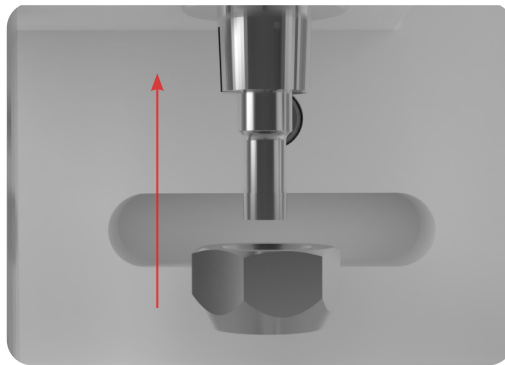

25.1 Note: Rotate the Hand Wheel to see that the Upper Punch smoothly enters the Die bore and that the Die is seated firmly in the Upper Drift Pin Assembly. To watch a video on proper Base Plate alignment, go to <https://www.lfatabletpresses.com/videos/how-to-align-a-baseplate-on-a-tdp-5>

26. Reinsert the Base Plate's bolts.
- 26.1 Note: The Die's bolt can be fully tightened now.

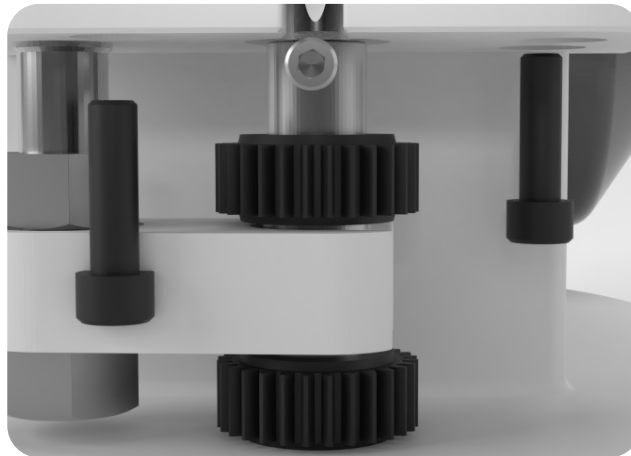

27. Position the Boot back on the Base Plate.
28. Insert the Boot Timing Bar's end in the Boot
29. Resecure the Boot Bolt and Spring underneath the Boot with an Allen key.
30. Tighten the Boot's set screw with an Allen key.
31. Reattach the Ejection Tray with an Allen key.
32. Reinsert the Hopper.
33. Turn the Hand Wheel for one rotation of the Top Cam Drive Shaft to ensure that the machine runs smoothly before plugging it in and turning it on.

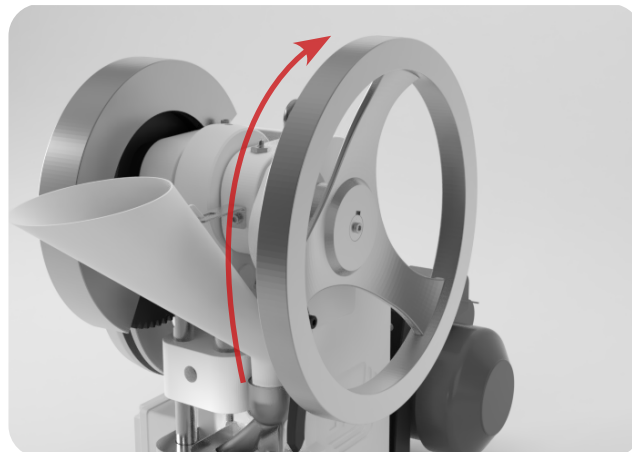

## Upper Drift Pin Assembly Rod Eye and Clevis

This part connects the Eccentric Sheave Strap and the Upper Drift Pin Assembly. It can become threaded or warped in the case of accidental collision and can be easily removed and replaced.

### Tools and Materials Needed

- Set of metric Allen keys with ball ends
- 24 mm wrenches (2)
- Circlip pliers
- New Upper Drift Pin Assembly Rod Eye and Clevis part
- Disposable latex/rubber gloves (for food grade products and to protect hands from grease)
- Hairnet and/or beard net (food grade products only)
- Sterile shoe covers (food grade products only)



**WARNING:** To prevent any potential personal injury, ALWAYS unplug the TDP 5<sup>®</sup> from the electrical outlet when replacing parts.

### Instructions

Note: Wear latex/rubber gloves (and appropriate food grade attire if applicable) during this process.

#### Remove the Upper Drift Pin Assembly Rod Eye and Clevis

1. Remove the Hopper carefully and catch any powder still inside of it.
2. Remove the Ejection Tray with an Allen key.

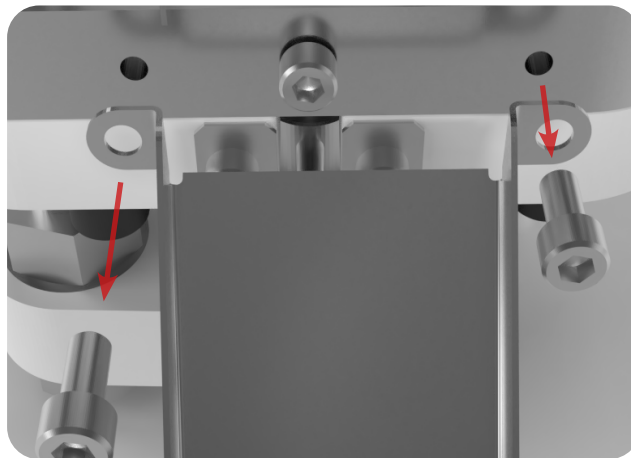

3. Loosen the Boot's set screw with an Allen key.

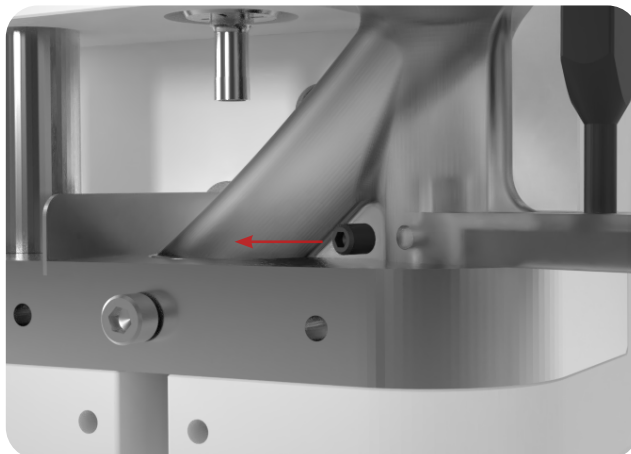

4. Loosen the Boot's set screw with an Allen key.
5. Remove the Boot Bolt and Spring underneath the Boot with an Allen key.

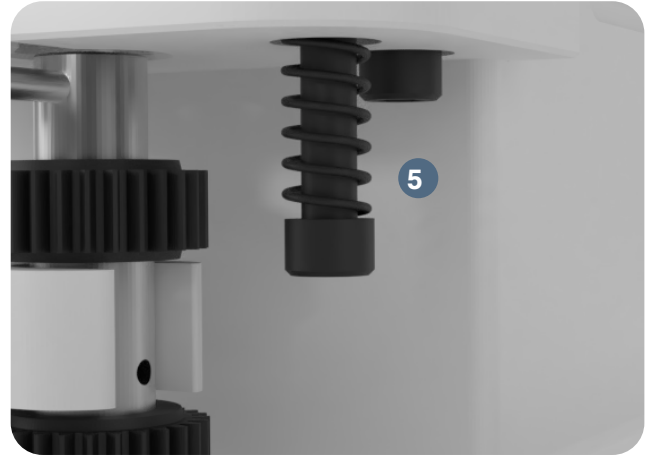
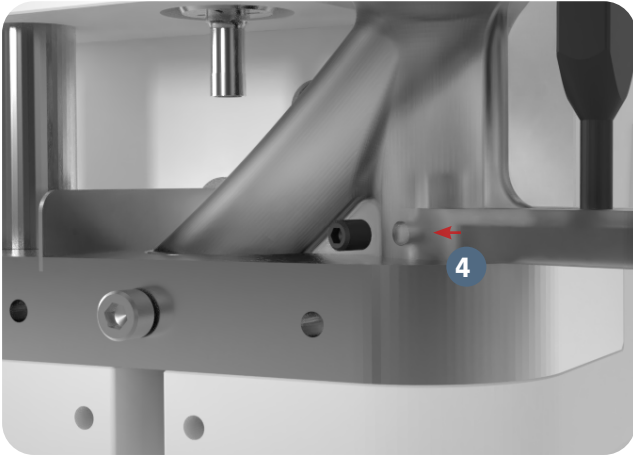

6. Take off the Boot carefully and remove any powder still inside it.
7. Loosen the bolts underneath the Base Plate with an Allen key.

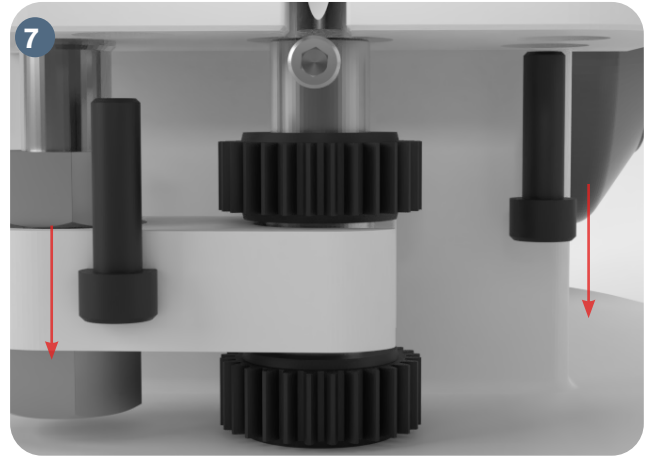
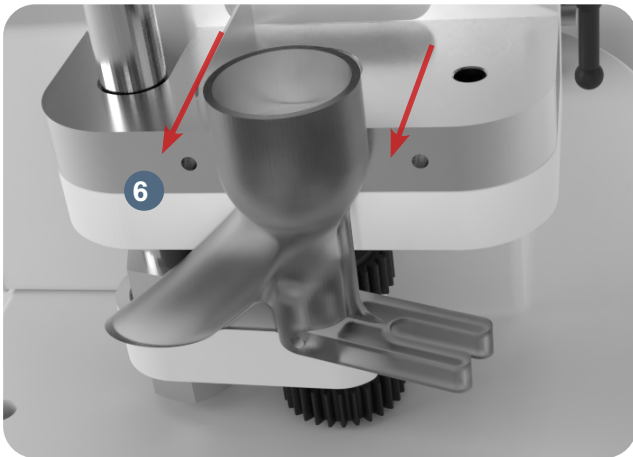

8. Turn the Hand Wheel until the Upper Drift Pin Assembly is lowered.
9. Loosen the Upper Punch Die Locking Nut with a wrench while keeping the Upper Punch Drift Assembly in place with another wrench.

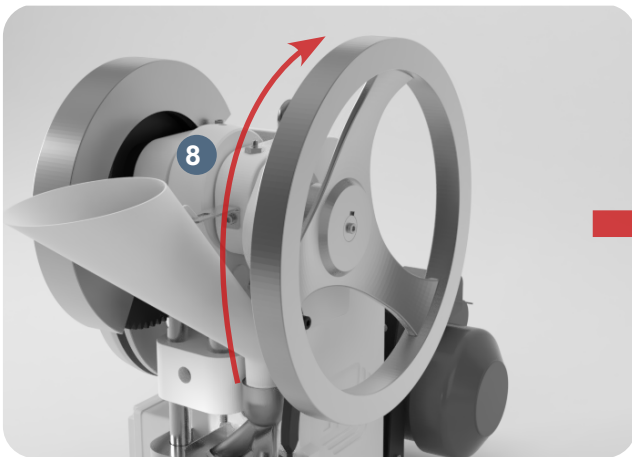



10. Remove the Upper Punch by hand.

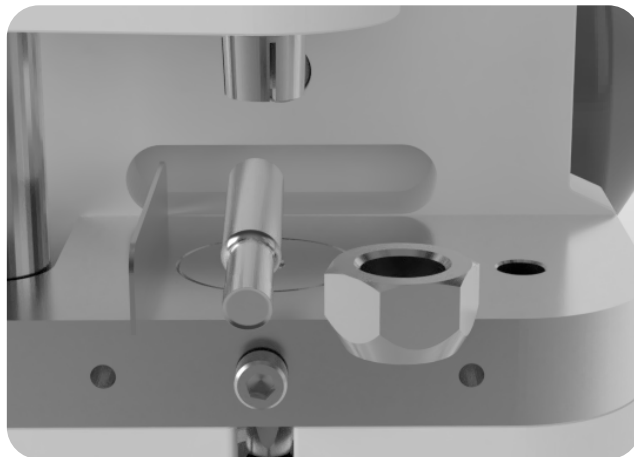

10.1 Note: If you cannot remove by hand, carefully use grippers or pliers.

11. Remove the Base Plate with the Die still inside it.

12. Remove the bolt that locks the Die with an Allen key.

13. Take out the Die from the middle of the Base Plate.

13.1 Tap the Die with a hammer if it is difficult to remove.

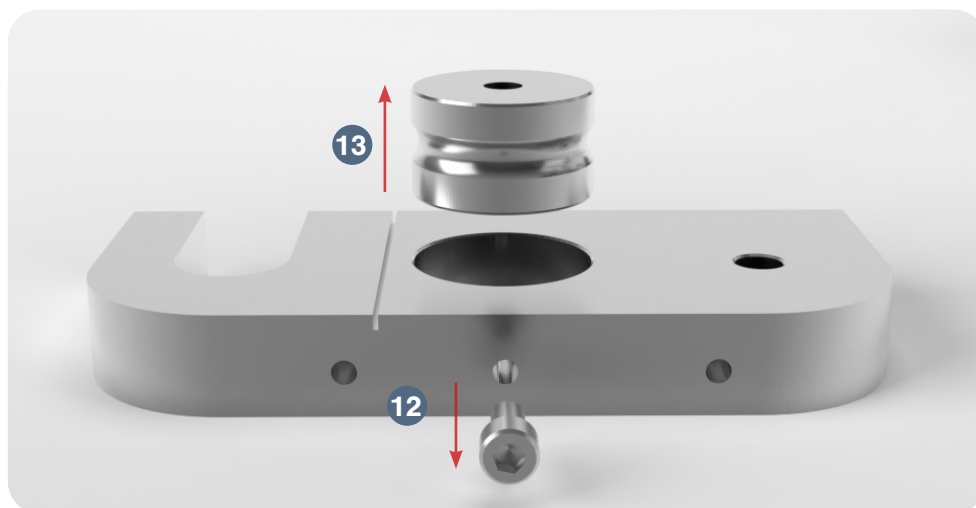

14. Remove the bolt that locks the Lower Punch with an Allen key.

15. Remove the Lower Punch by hand.

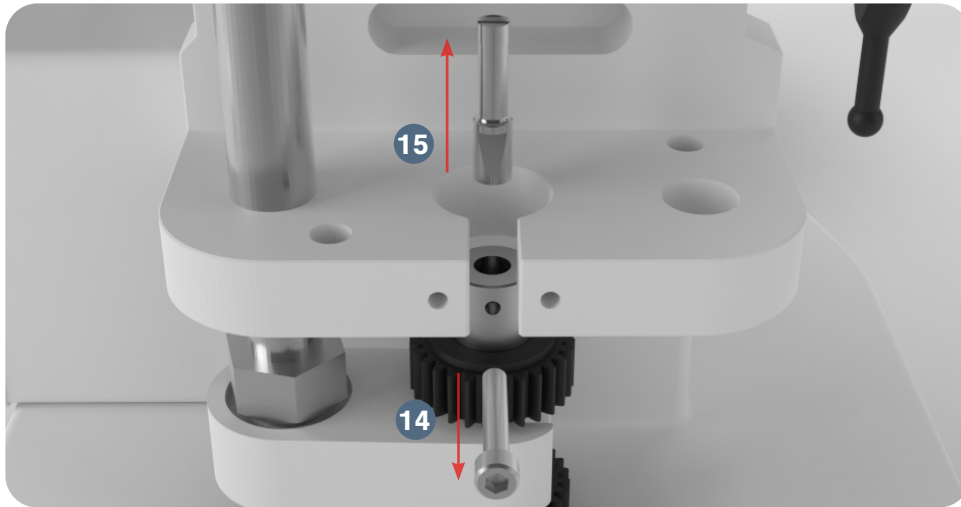

16. Loosen the Upper Drift Pin Assembly Locking Nut with a wrench.

17. Unscrew the Upper Drift Pin Assembly from the Upper Drift Pin Assembly Rod Eye and Clevis.

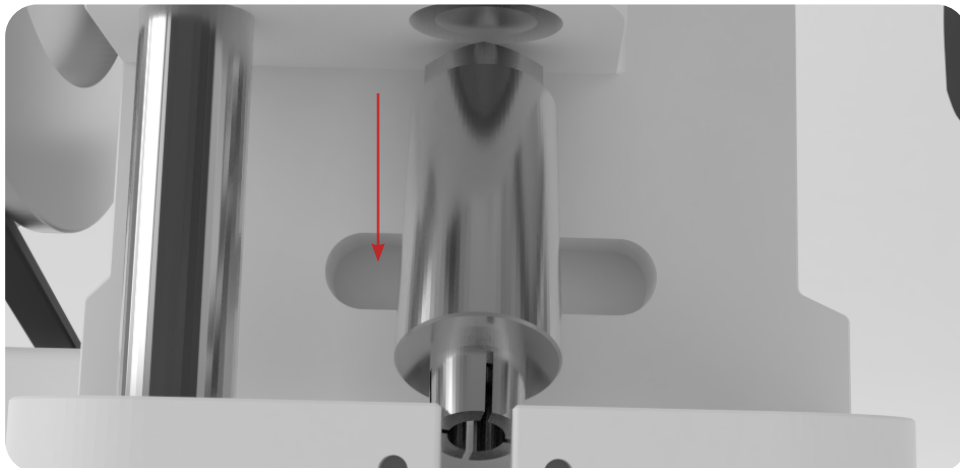

18. Remove the Upper Drift Pin Assembly Rod Eye and Clevis's circlip with circlip pliers.

19. Remove the Upper Drift Pin Assembly Rod Eye and Clevis's pin from the Eccentric Sheave Strap.

19.1 Note: Lightly tap the pin with a screwdriver or something similar to aid in its removal.

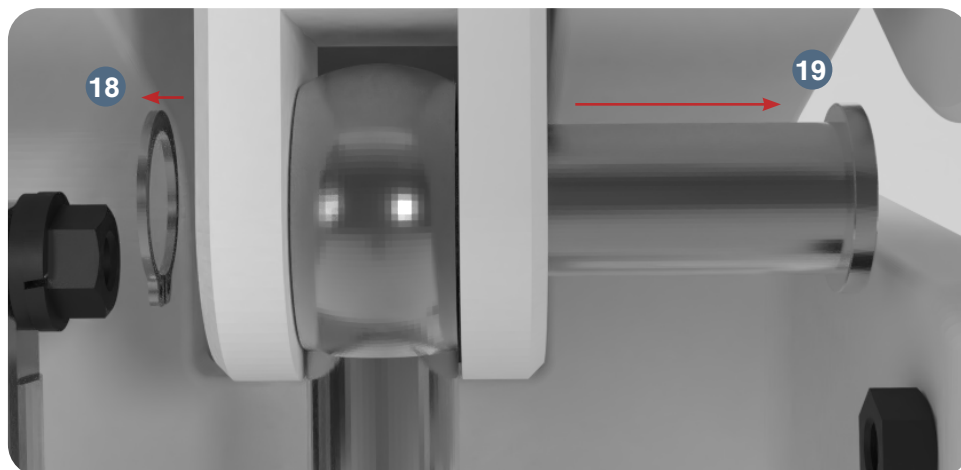

20. Remove the Upper Drift Pin Assembly Rod Eye and Clevis from the Eccentric Sheave Strap.

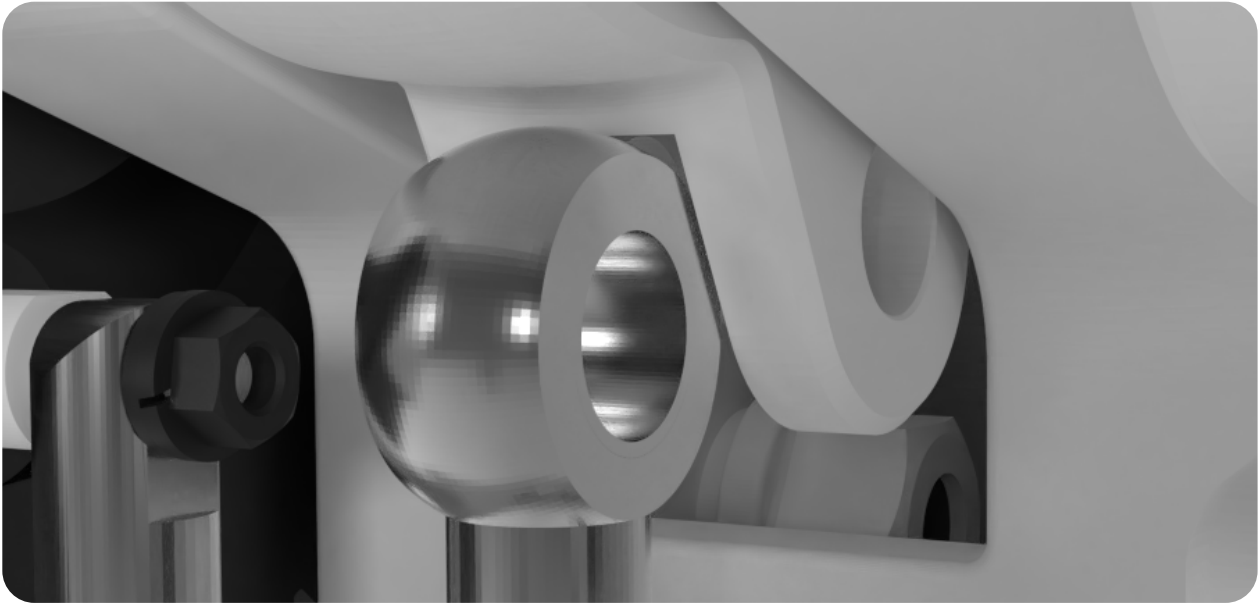

**Replace the Upper Drift Pin Assembly Rod Eye and Clevis**

21. Reinsert the Upper Drift Pin Assembly Rod Eye and Clevis's pin and secure it with a circlip.

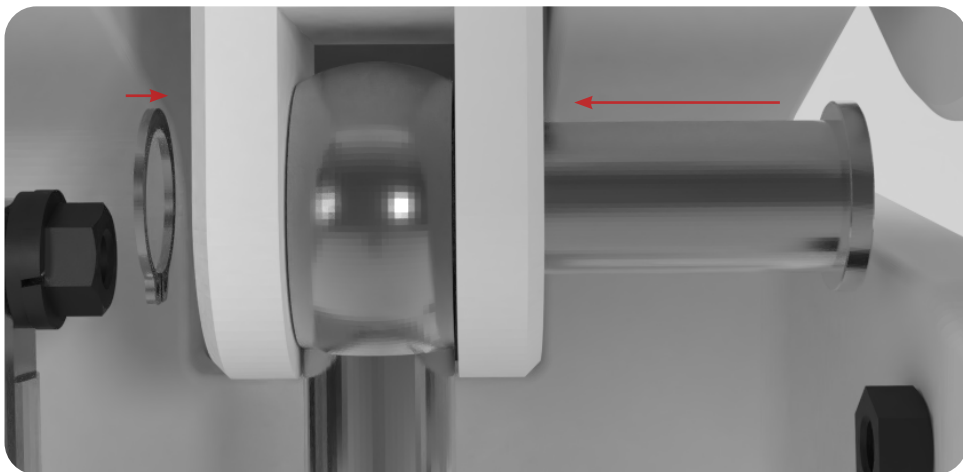

22. Tighten the Upper Drift Pin Assembly Locking Nut onto the new Upper Drift Pin Assembly Rod Eye and Clevis by hand or with a wrench.

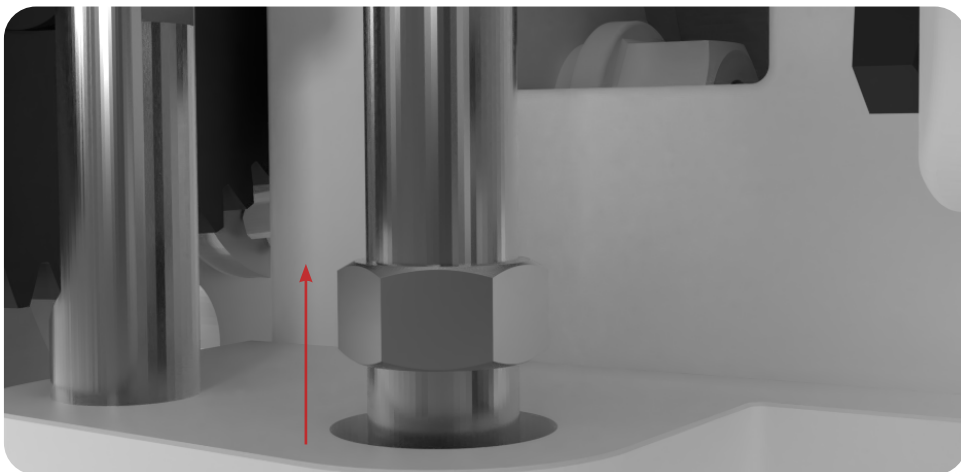

23. Screw the Upper Drift Pin Assembly into the new Upper Drift Pin Assembly Rod Eye and Clevis.

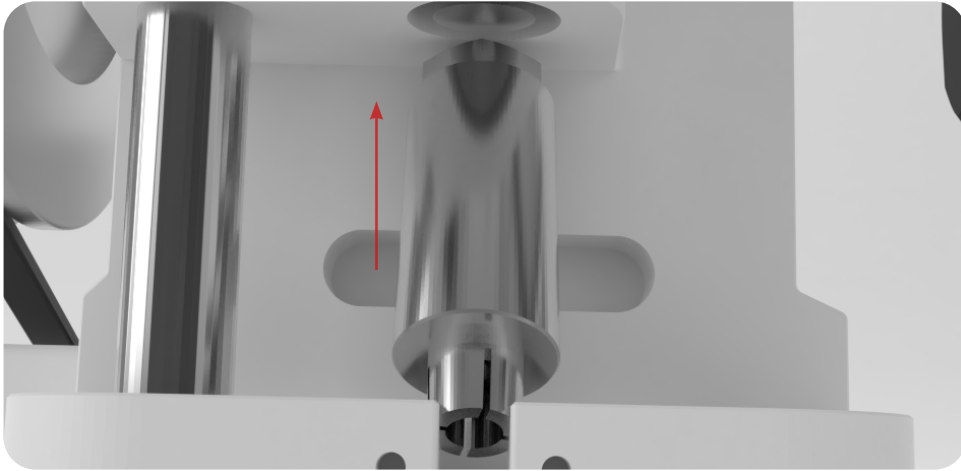

24. Reinsert the Lower Punch into the Lower Drift Pin Assembly.

25. Reinsert the bolt that locks the Lower Punch with an Allen key.

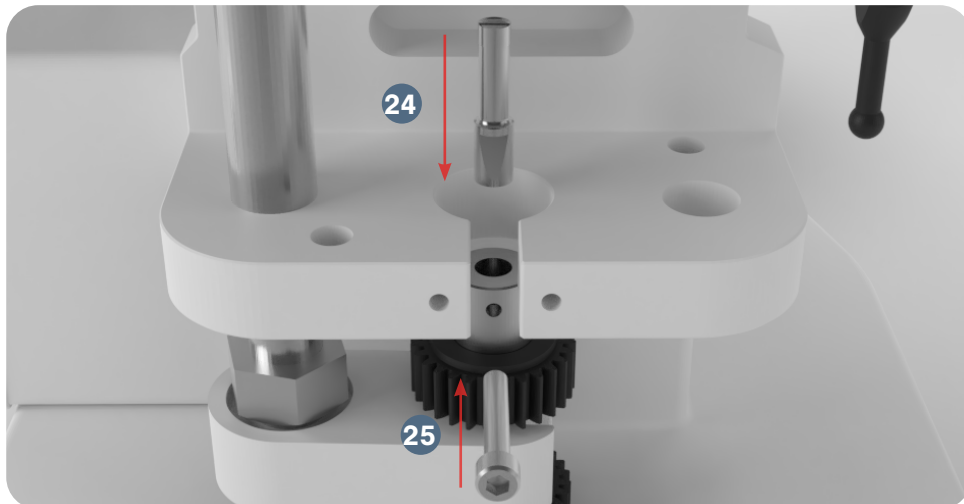

25.1 Note: Make sure that the Lower Punch's "keyed" section is facing forward.

26. Place the Base Plate onto the TDP 5® Base.

27. Insert the Die into the middle of the Base Plate.

28. Reinsert the bolt that locks the Die with an Allen key.

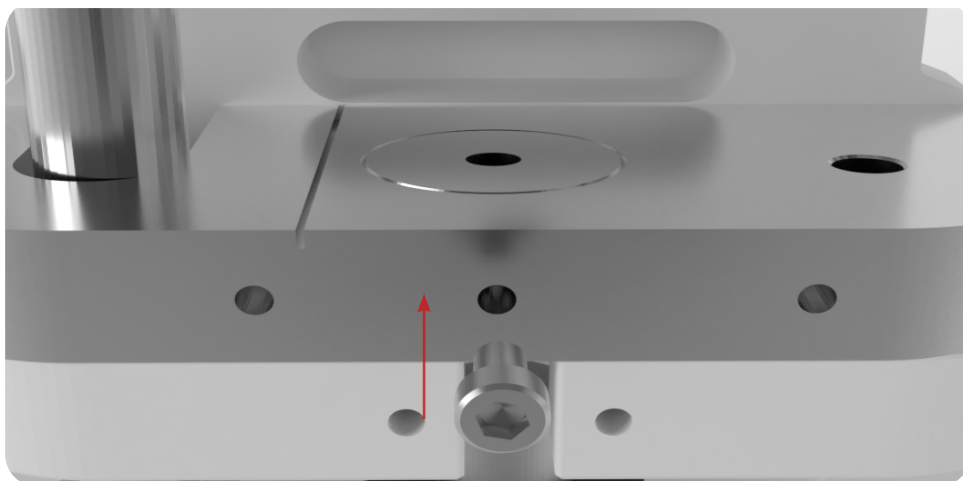

29. Insert the Upper Punch into the Upper Drift Pin Assembly.
30. Tighten the Upper Punch Die Locking Nut onto the Upper Drift Pin Assembly with a wrench.

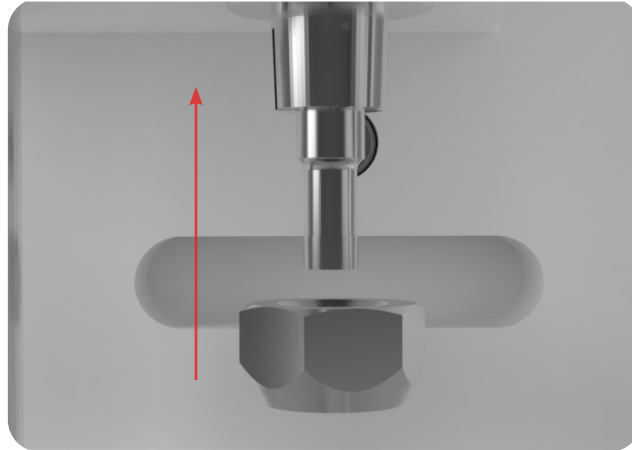

30.1 Note: Rotate the Hand Wheel to see that the Upper Punch smoothly enters the Die bore and that the Die is seated firmly in the Upper Drift Pin Assembly. To watch a video on proper Base Plate alignment, go to <https://www.lfatabletpresses.com/videos/how-to-align-a-baseplate-on-a-tdp-5>

31. Reinsert the Base Plate's bolts.

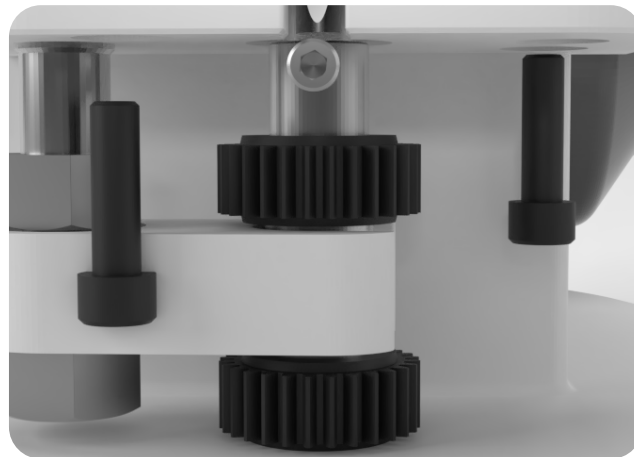

32. Position the Boot back on the Base Plate.
33. Insert the Boot Timing Bar's end in the Boot
34. Resecure the Boot Bolt and Spring underneath the Boot with an Allen key.
35. Tighten the Boot's set screw with an Allen key.
36. Reattach the Ejection Tray with an Allen key.
37. Reinsert the Hopper.
38. Turn the Hand Wheel for one rotation of the Top Cam Drive Shaft to ensure that the machine runs smoothly before plugging it in and turning it on.

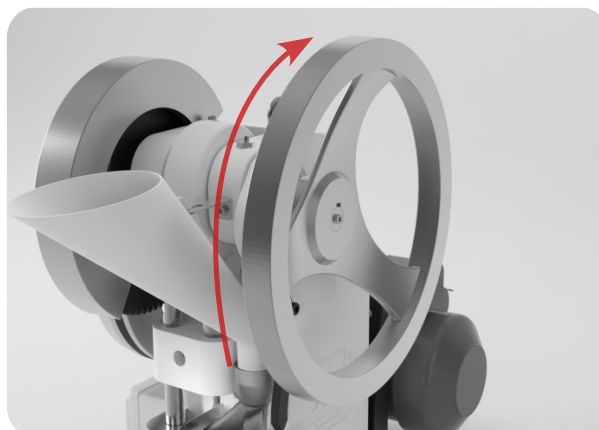

## Lower Drift Pin Assembly

The Lower Drift Pin Assembly may need to be removed if any pins become stuck inside it and/or the Lower Drift Pin Assembly Cogs become jammed on it.

### Tools and Materials Needed

- Set of metric Allen keys with ball ends
- 24 mm wrenches (2)
- New Lower Drift Pin Assembly part
- Disposable latex/rubber gloves (for food grade products and to protect hands from grease)
- Hairnet and/or beard net (food grade products only)
- Sterile shoe covers (food grade products only)



**WARNING:** To prevent any potential personal injury, ALWAYS unplug the TDP 5<sup>®</sup> from the electrical outlet when replacing parts.

### Instructions

Note: Wear latex/rubber gloves (and appropriate food grade attire if applicable) during this process.

#### Remove the Lower Drift Pin Assembly

1. Remove the Hopper carefully and catch any powder still inside of it.
2. Remove the Ejection Tray with an Allen key.

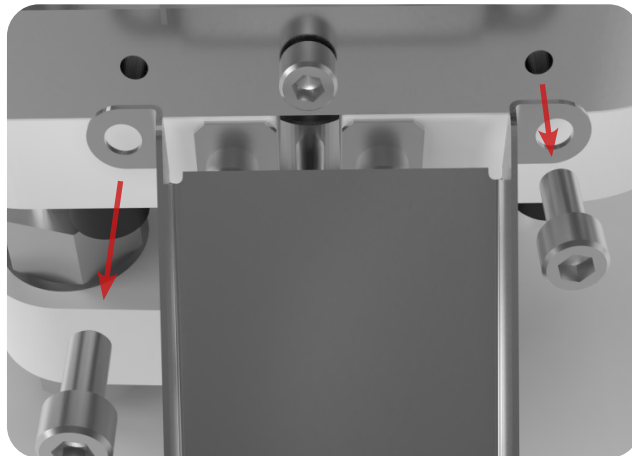

3. Loosen the Boot's set screw with an Allen key.
4. Remove the Boot Bolt and Spring underneath the Boot with an Allen key.

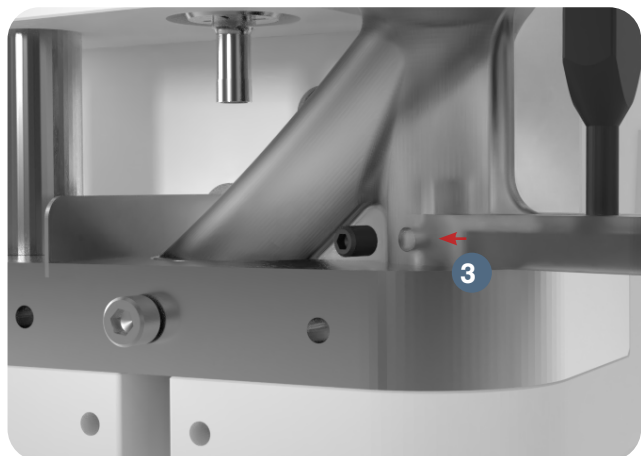

5. Take off the Boot carefully and remove any powder still inside it.
6. Loosen the bolts underneath the Base Plate with an Allen key.

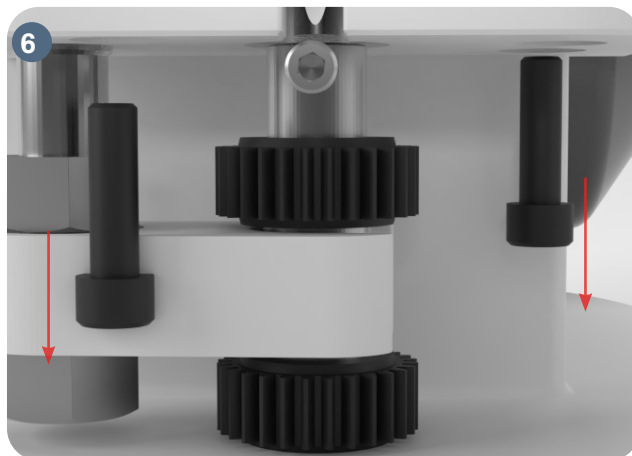
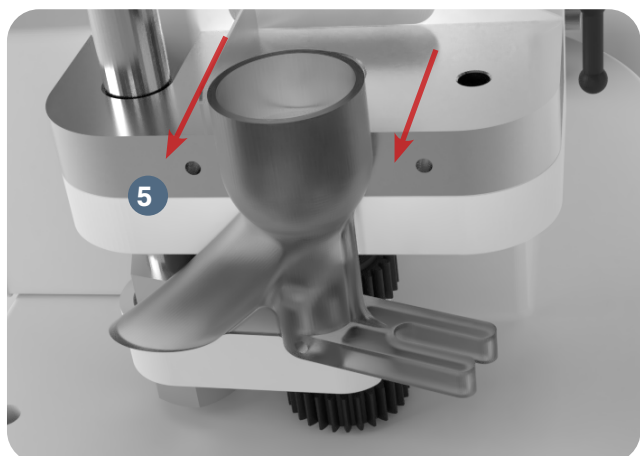

7. Remove the Base Plate with the Die still inside it.
8. Remove the bolt that locks the Die with an Allen key.
9. Take out the Die from the middle of the Base Plate.
  - 9.1 Lightly tap the Die with a hammer if it is difficult to remove.

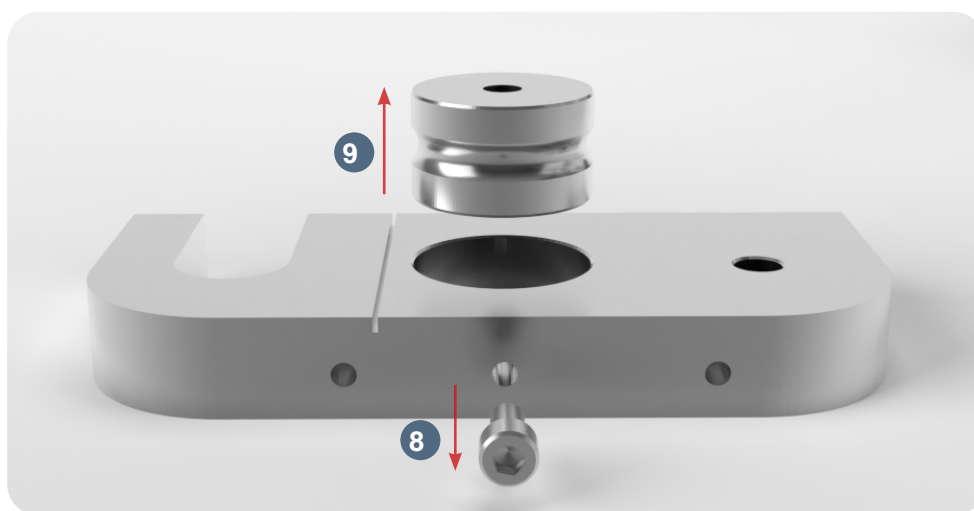

10. Remove the bolt that locks the Lower Punch with an Allen key.
11. Remove the Lower Punch by hand.

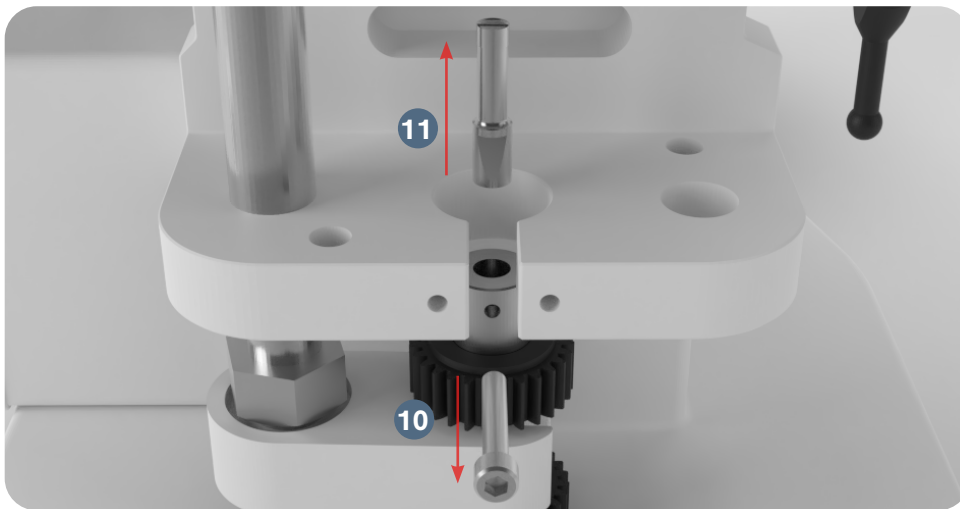

11.1 Note: If you cannot remove by hand, carefully use grippers or pliers.

12. Remove the Lower Drift Pin Assembly Locking Bar with an Allen key.

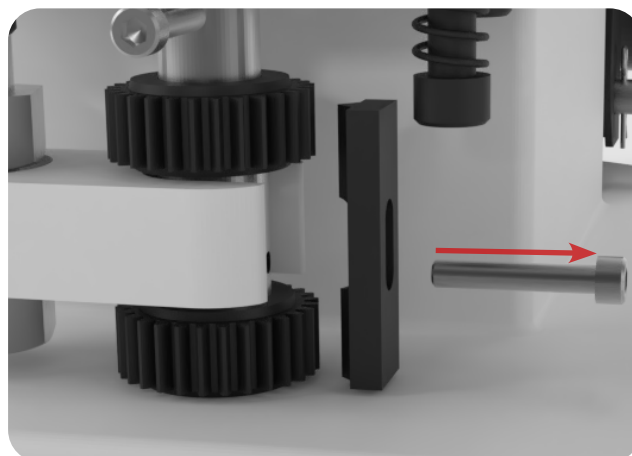

13. Rotate the Lower Drift Pin Assembly Cogs to remove them from the Lower Drift Pin Assembly.

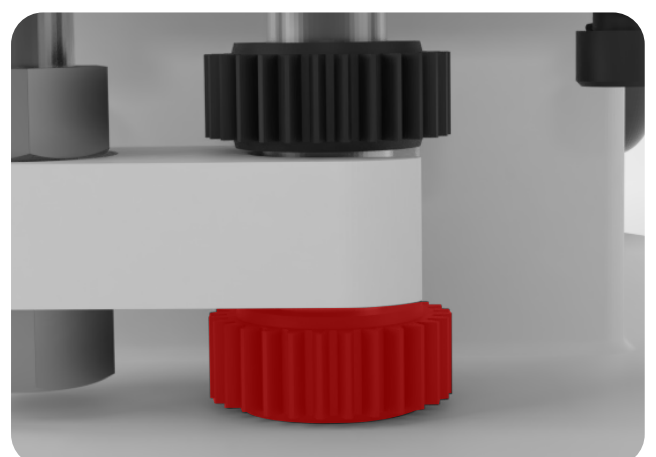
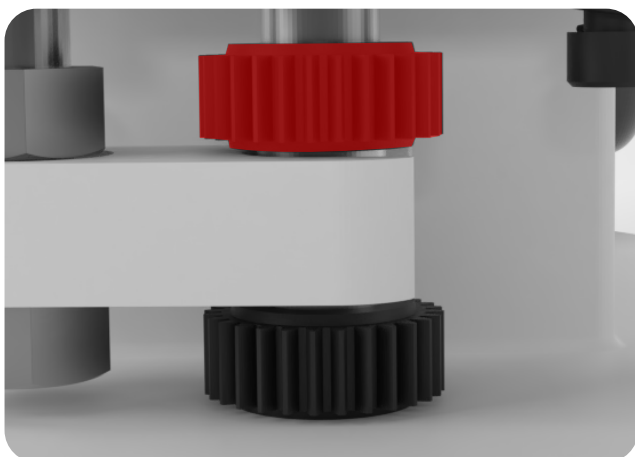



14. Remove the bolts from the Upper Drift Pin Assembly Mounting Block with an Allen key.
15. Take off the Upper Drift Pin Assembly Mounting Block and remove the Lower Drift Pin Assembly.

**Replace the Lower Drift Pin Assembly**

16. Insert the new Lower Drift Pin Assembly into the Base and Upper Drift Pin Assembly Mounting Block.

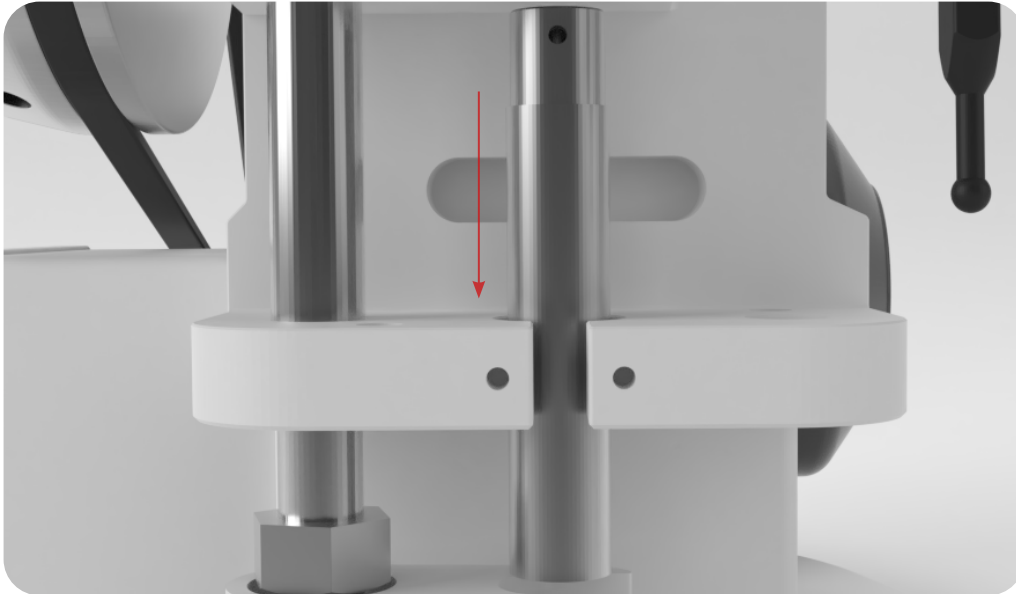

17. Reattach the Upper Drift Pin Assembly Mounting Block to the Base with an Allen key.
  - 17.1 Note: Be sure that the Lower Drift Pin Assembly Timing Rod Runner Bolt is placed on the Cam Drive Cog.

18. Rotate one of the Lower Drift Pin Assembly Cogs onto the new Lower Drift Pin Assembly.



19. Raise the Lower Drift Pin Assembly Cog just below the bolt bore on the Lower Drift Pin Assembly.

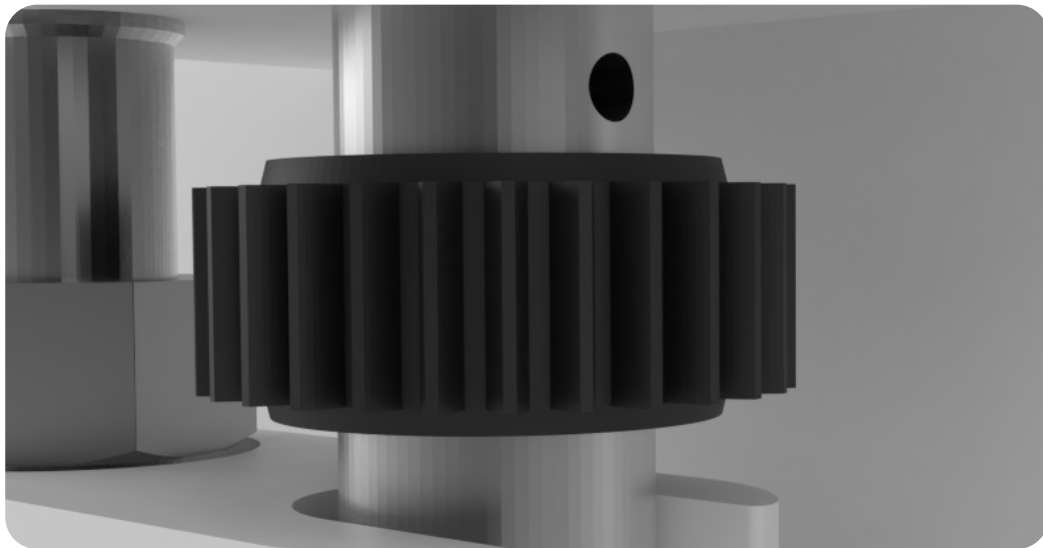

20. Rotate the remaining Lower Drift Pin Assembly Cog onto the Lower Drift Pin Assembly below the Lower Drift Pin Assembly Timing Bar.

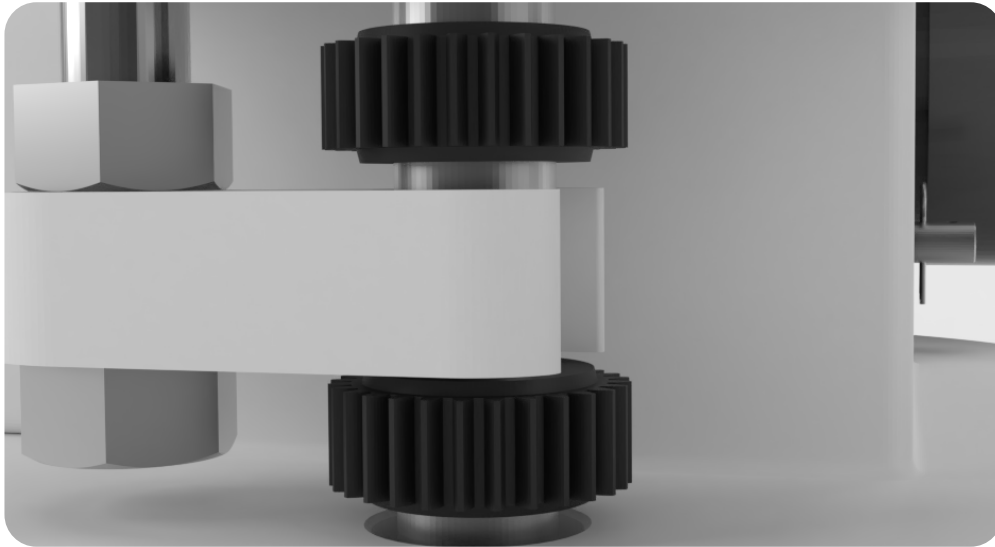

21. Rescrew the bolt into the Lower Drift Pin Assembly Locking Bar with an Allen key.

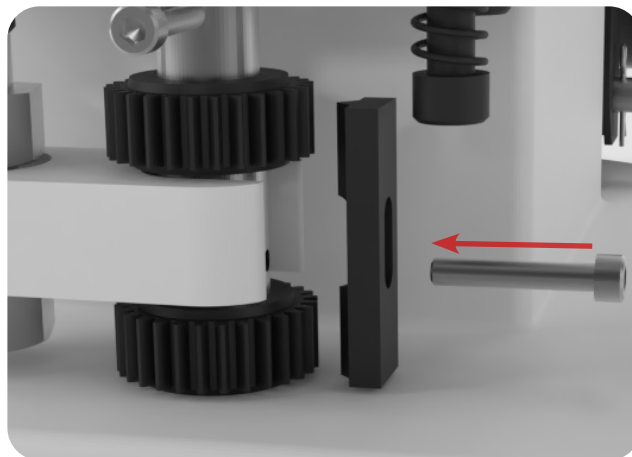

21.1 Note: Ensure that the Lower Drift Pin Assembly Locking Bar is situated vertically.

22. Reinsert the Lower Punch into the new Lower Drift Pin Assembly.
23. Reinsert the bolt that locks the Lower Punch with an Allen key.

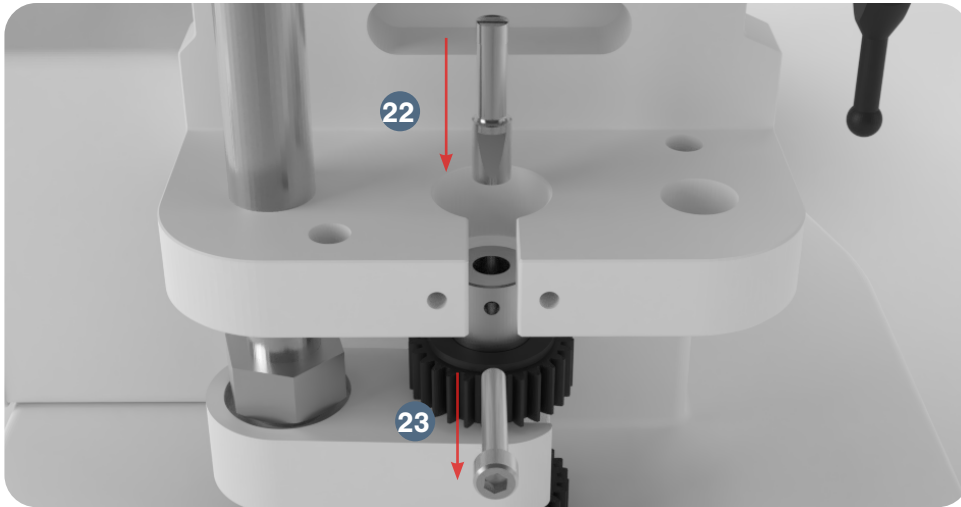

- 23.1 Note: Make sure that the Lower Punch's “keyed” section is facing forward.
24. Place the Base Plate onto the TDP 5® Base.
  25. Reinsert the Die into the middle of the Base Plate.
  26. Reinsert the bolt that locks the Die with an Allen key.

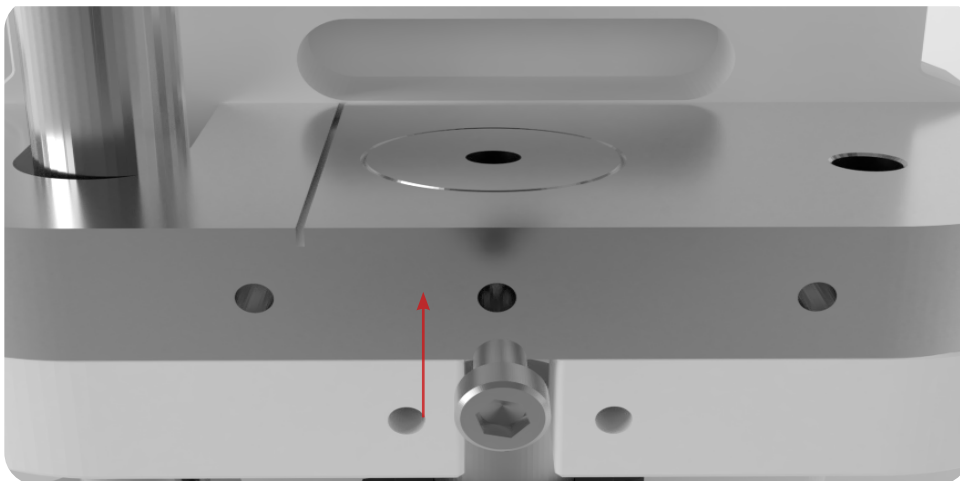

27. Reinsert the Base Plate's bolts.

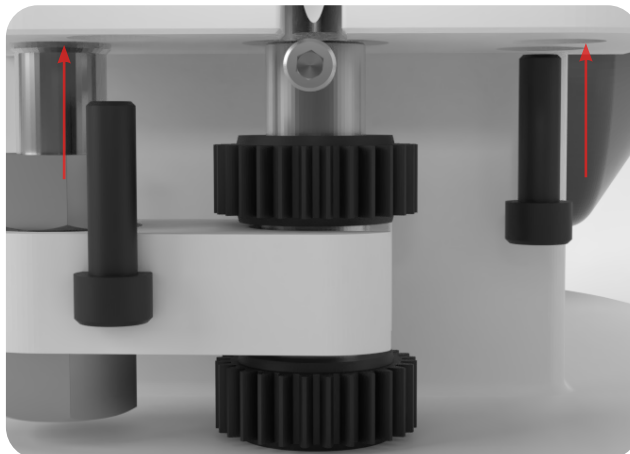

28. Position the Boot back on the Base Plate.

29. Insert the Boot Timing Bar's end in the Boot

30. Resecure the Boot Bolt and Spring underneath the Boot with an Allen key.

31. Tighten the Boot's set screw with an Allen key.

32. Reinsert the Hopper.

33. Reattach the Ejection Tray with an Allen key.

34. Turn the Hand Wheel for one rotation of the Top Cam Drive Shaft to ensure that the machine runs smoothly before plugging it in and turning it on.

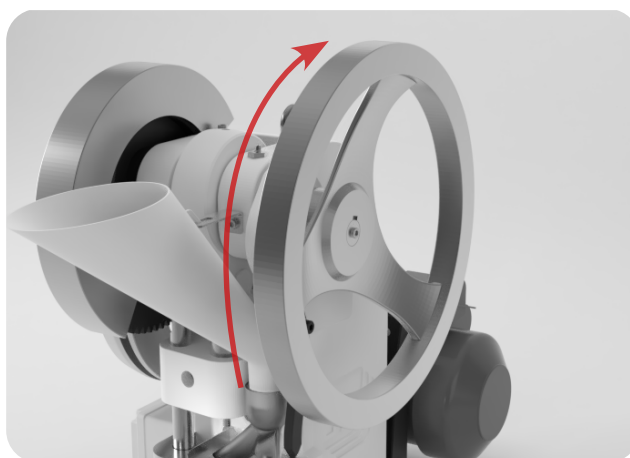

## Lower Drift Pin Assembly Timing Rod and Runner Bolt

The Lower Drift Pin Assembly Timing Rod and its Runner Bolt can be damaged due to overtightening and/or being under too much pressure.

### Tools and Materials Needed

- Set of metric Allen keys with ball ends
- 17 mm and 30 mm wrenches
- New Lower Drift Pin Assembly Rod and Runner Bolt parts
- Disposable latex/rubber gloves (for food grade products and to protect hands from grease)
- Hairnet and/or beard net (food grade products only)
- Sterile shoe covers (food grade products only)



**WARNING:** To prevent any potential personal injury, ALWAYS unplug the TDP 5® from the electrical outlet when replacing parts.

### Instructions

Note: Wear latex/rubber gloves (and appropriate food grade attire if applicable) during this process.

#### Remove the Lower Drift Pin Assembly Timing Rod

1. Remove the Hopper carefully and catch any powder still inside of it.
2. Remove the Ejection Tray with an Allen key.

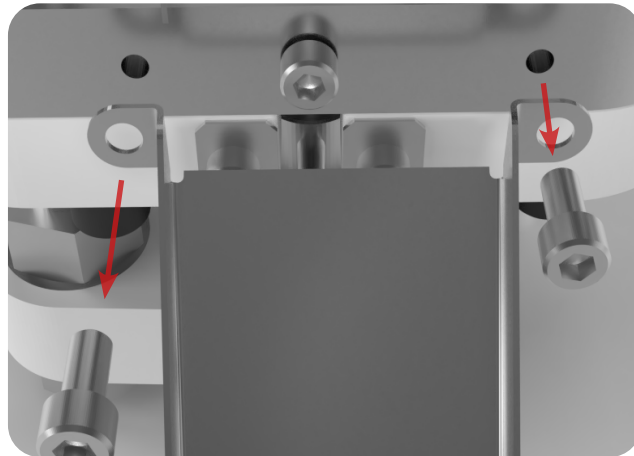

3. Remove the Boot and Upper Punch from the machine.

3.1 Note: For further information on removing these parts, please refer to the Tooling repair and replacement instructions on page 33.

4. Loosen the two nuts on the Lower Drift Pin Assembly Timing Rod with a wrench.

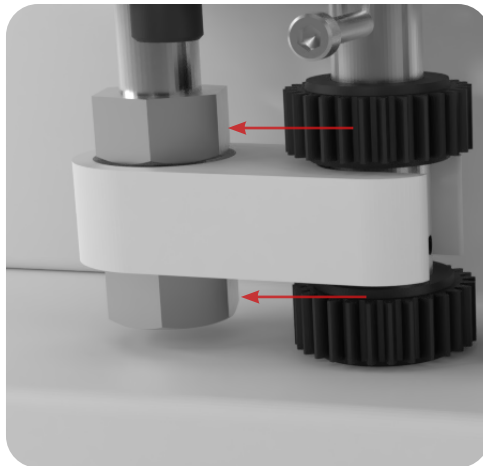

5. Move the Electrical Drive Flywheel and Cam Drive Cog to make more space.

5.1 Note: For further information on how to access these parts, please refer to the Electrical Drive Flywheel repair and replacement instructions on page 72.

6. Remove the three screws from the Mounting Block with an Allen key.

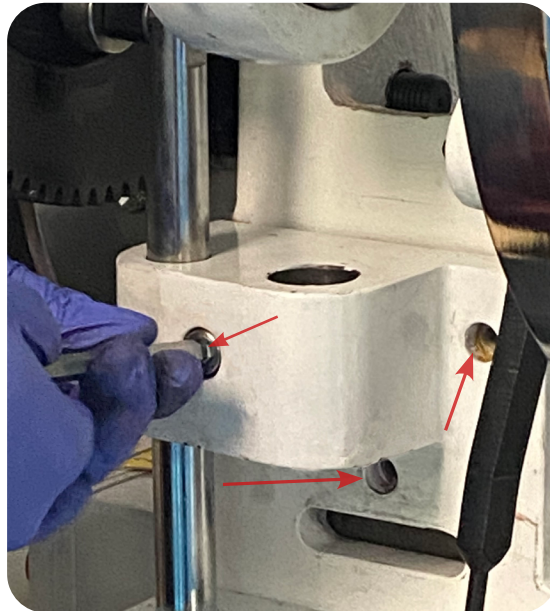

7. Carefully pull off the Mounting Block from the machine.

8. Remove the Lower Drift Pin Assembly Timing Rod with its Runner Bolt from the Mounting Block.

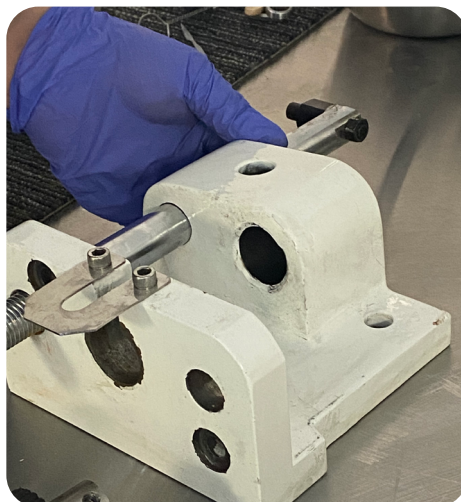

9. Unscrew the nut on the Lower Drift Pin Assembly Timing Rod Runner Bolt with a wrench.

### Replace the Lower Drift Pin Assembly Timing Rod

10. Insert the runner onto the new Lower Drift Pin Assembly Timing Rod Runner Bolt.
11. Tighten the nut onto the new Lower Drift Pin Assembly Timing Rod Runner Bolt with a wrench.
12. Insert the new Lower Drift Pin Assembly Timing Rod into the Mounting Block.
13. Place the Mounting Block (with the new Lower Drift Pin Assembly Timing Rod) onto the machine and place the Lower Drift Pin Timing Rod Runner Bolt with its runner into the Cam Drive Cog.
- 13.1 Note: Ensure that the new Lower Drift Pin Assembly Timing Rod is inserted into the Lower Drift Pin Assembly Lifting Bar.
14. Re-tighten the two nuts on the Lower Drift Pin Assembly Timing Rod with a wrench.
- 14.1 Note: Make sure that the Lower Drift Pin Assembly is fully down and adjust the two nuts until the Lower Drift Pin Assembly Lifting Bar is perfectly level and resting on the fill depth adjustment cog.

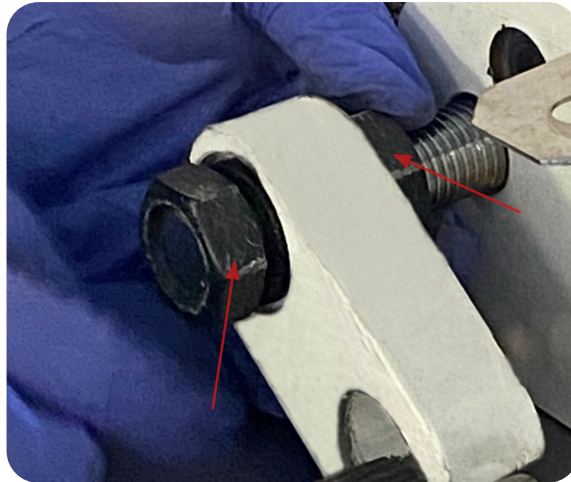

15. While holding the Mounting Block against the Base, tighten the three screws with an Allen key.
16. Re-install the Boot and the Upper Punch onto the machine.
- 16.1 Note: For further information on installing these parts, please refer to the Tooling repair and replacement instructions on page 33.
17. Reinsert the Hopper.
18. Reattach the Ejection Tray with an Allen key.
19. Turn the Hand Wheel for one rotation of the Top Cam Drive Shaft to ensure that the machine runs smoothly before plugging it in and turning it on.

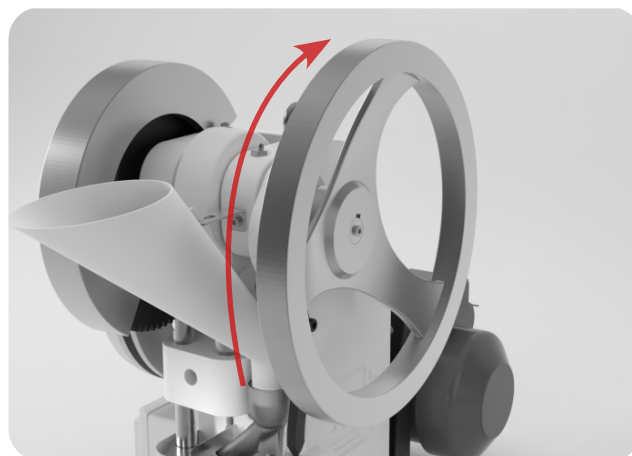



## V Belt

Although this part is rugged and long-lasting, after time it may become worn out and requires a replacement.

### Tools and Materials Needed

- 19 mm wrench
- New V Belt part
- Disposable latex/rubber gloves (for food grade products and to protect hands from grease)
- Hairnet and/or beard net (food grade products only)
- Sterile shoe covers (food grade products only)



**WARNING:** To prevent any potential personal injury, ALWAYS unplug the TDP 5 from the electrical outlet when replacing parts.

### Instructions

Note: Wear latex/rubber gloves (and appropriate food grade attire if applicable) during this process.

#### Remove the V Belt

1. Adjust the nuts on the Motor Support Arm with a 19 mm wrench to loosen the V Belt.
  - 1.1 Note: The closer the Motor Mounting Plate is to the TDP 5<sup>®</sup>, the looser the V Belt's slack will be.

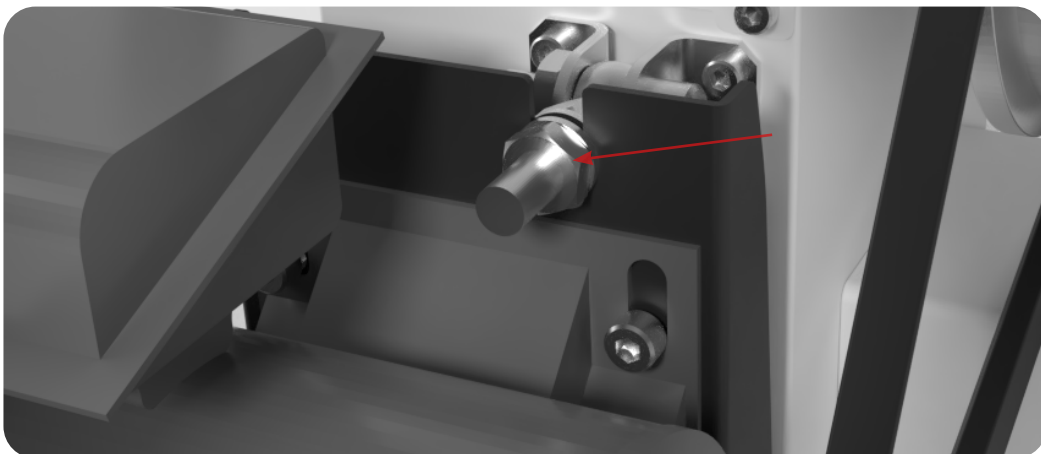

2. Remove the V Belt from the Drive Belt Pulley and the Electrical Drive Flywheel.

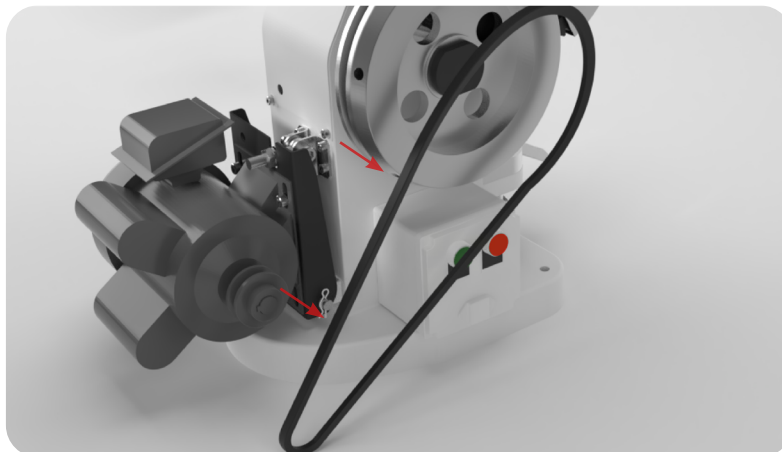

## Replace the V Belt

3. Place the new V Belt onto the Drive Belt Pulley and the Electrical Drive Flywheel.

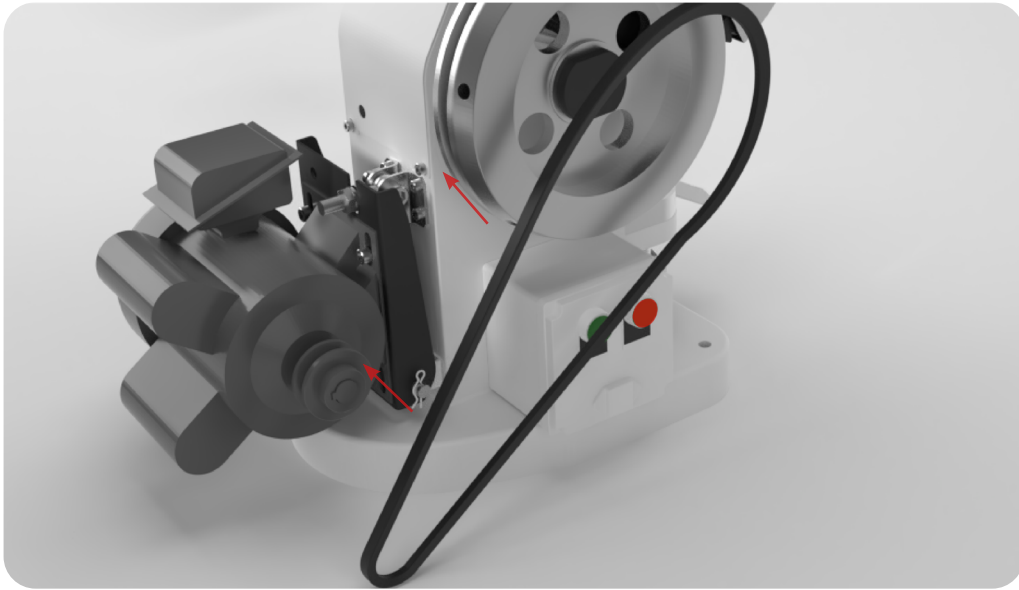

4. Adjust the nut on the Motor Support Arm to tighten the V Belt.

4.1 Note: The further away the Motor Mounting Plate is from the TDP 5<sup>®</sup>, the tighter the V Belt's slack will be. The correct tension for a new V Belt is [N] 141.64.

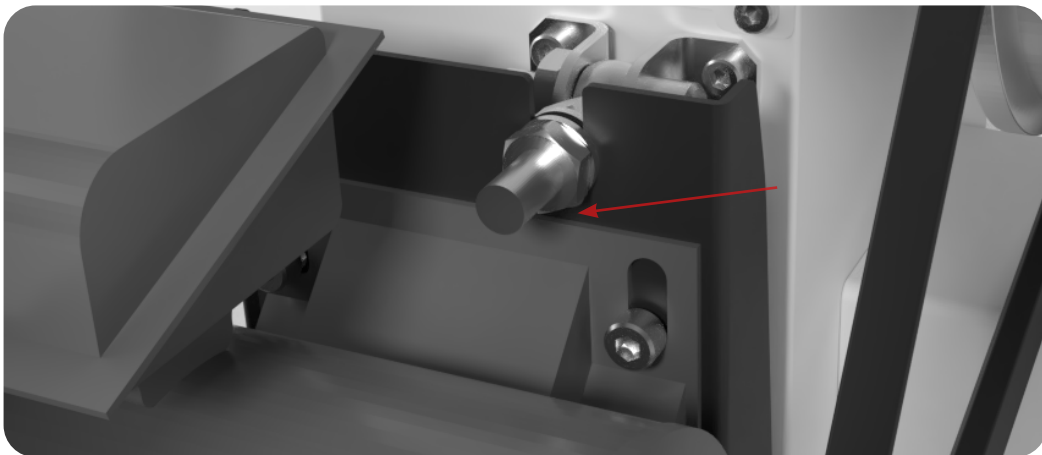

5. Turn the Hand Wheel for one rotation of the Top Cam Drive Shaft to ensure that the machine runs smoothly before plugging it in and turning it on.

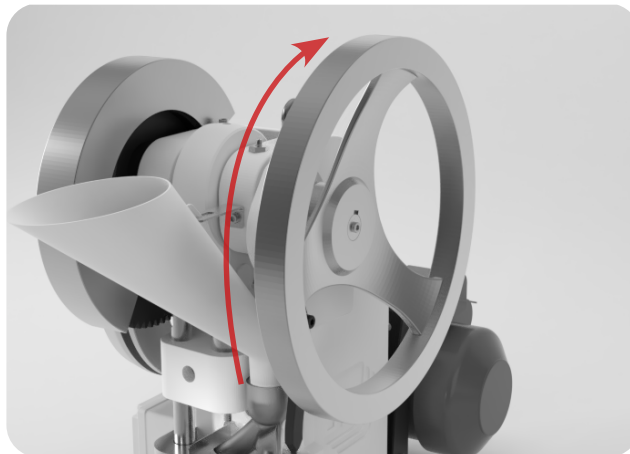

## Hand Wheel

Although this part is sturdy, it can be damaged from a fall or any other accident. Fortunately, it is a simple process to replace the Hand Wheel.

### Tools and Materials Needed

- Set of metric Allen keys with ball ends
- Rubber mallet
- New Hand Wheel part
- Disposable latex/rubber gloves (for food grade products and to protect hands from grease)
- Hairnet and/or beard net (food grade products only)
- Sterile shoe covers (food grade products only)



**WARNING:** To prevent any potential personal injury, ALWAYS unplug the TDP 5 from the electrical outlet when replacing parts.

### Instructions

Note: Wear latex/rubber gloves (and appropriate food grade attire if applicable) during this process.

#### Remove the Hand Wheel

1. Loosen the Hand Wheel Cap's bolt with an Allen key.
2. Disengage the Hand Wheel from the engraved key on the Top Cam Drive Shaft.
  - 2.1 Note: Use a rubber mallet if the Hand Wheel is difficult to remove.

#### Replace the Hand Wheel

3. Insert the new Hand Wheel onto the Top Cam Drive Shaft's engraved key.
4. Secure the Hand Wheel Cap back on with an Allen key.
5. Turn the Hand Wheel for one rotation of the Top Cam Drive Shaft to ensure that the machine runs smoothly before plugging it in and turning it on.

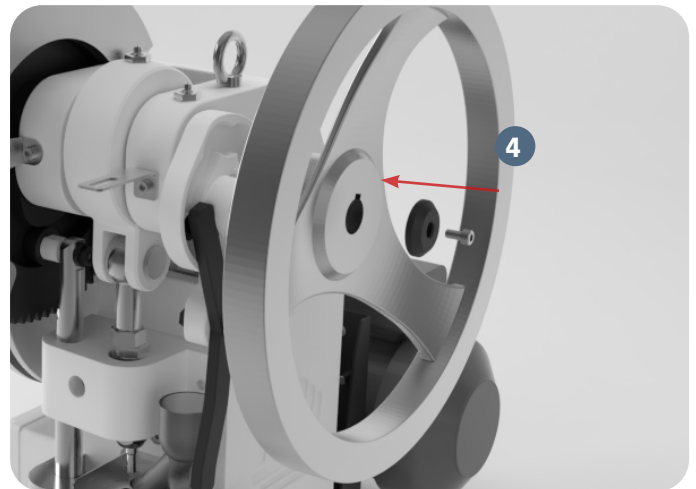
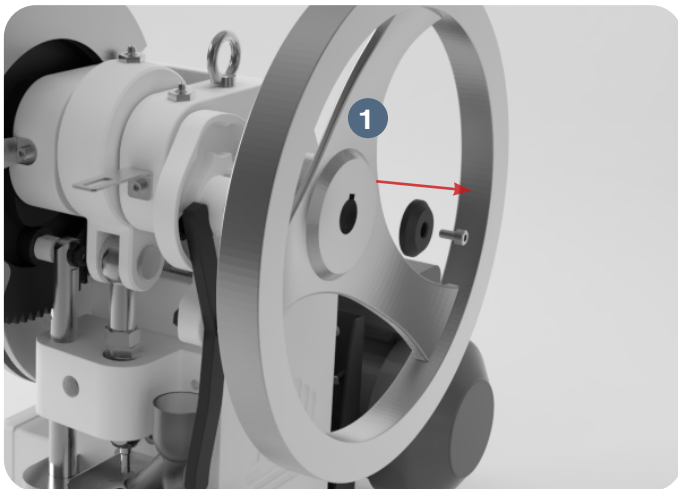

## Electrical Drive Flywheel

The V Belt drives this part to turn the Cam Drive Cog, which moves the Top Cam Drive Shaft. Whenever the machine seizes/jams, the De-Jamming Bar can be used on this part's holes to reduce the pressure of the Upper Drift Pin Assembly.

### Tools and Materials Needed

- Set of metric Allen keys with ball ends
- 19 mm wrench & 30 mm wrench
- Gear puller
- New Electrical Drive Flywheel part
- Disposable latex/rubber gloves (for food grade products and to protect hands from grease)
- Hairnet and/or beard net (food grade products only)
- Sterile shoe covers (food grade products only)



**WARNING:** To prevent any potential personal injury, ALWAYS unplug the TDP 5<sup>®</sup> from the electrical outlet when replacing parts.

### Instructions

Note: Wear latex/rubber gloves (and appropriate food grade attire if applicable) during this process.

#### Remove the Electrical Drive Flywheel

1. Adjust the nuts on the Motor Support Arm with a 19 mm wrench to loosen the V Belt.
  - 1.1 Note: The closer the Motor Mounting Plate is to the TDP 5<sup>®</sup>, the looser the V Belt's slack will be.

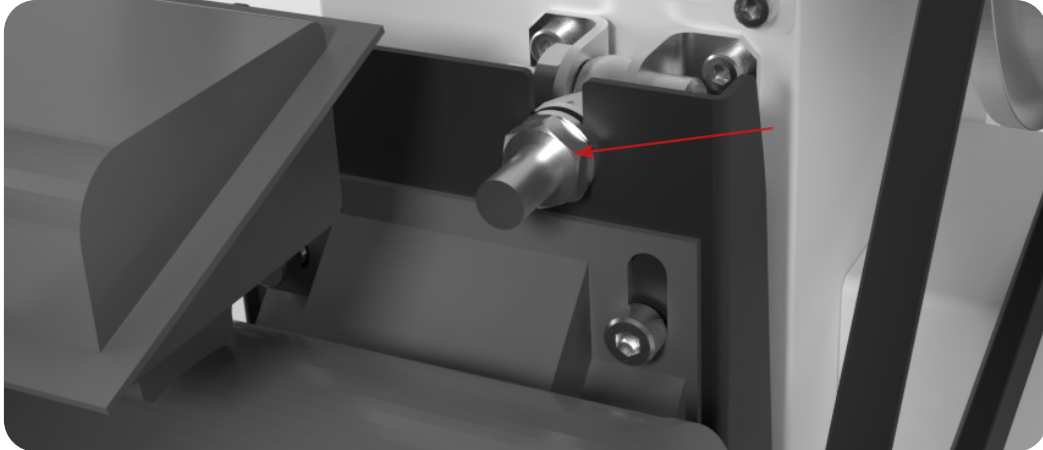

2. Remove the V Belt from the Drive Belt Pulley and the Electrical Drive Flywheel.

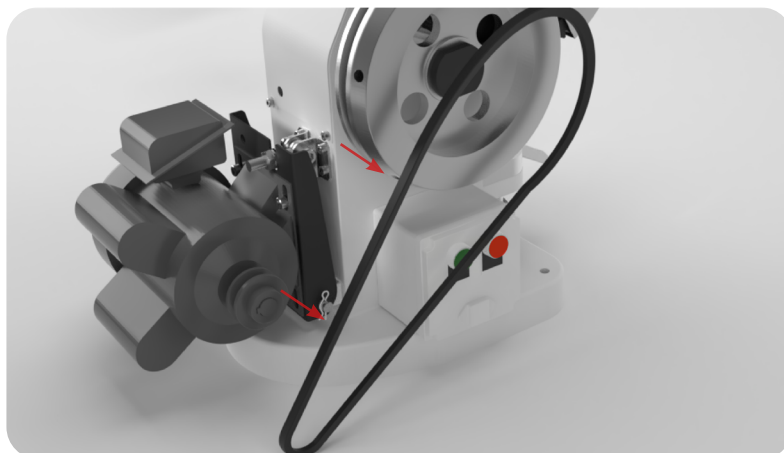

3. Remove the Rear Enclosure Plate off of the back of the TDP 5<sup>®</sup> with an Allen key.



4. Loosen the nut from the Pinion Gear Cam that connects the Pinion Gear and the Electrical Drive Flywheel to the TDP 5<sup>®</sup> Base with a 30 mm wrench.

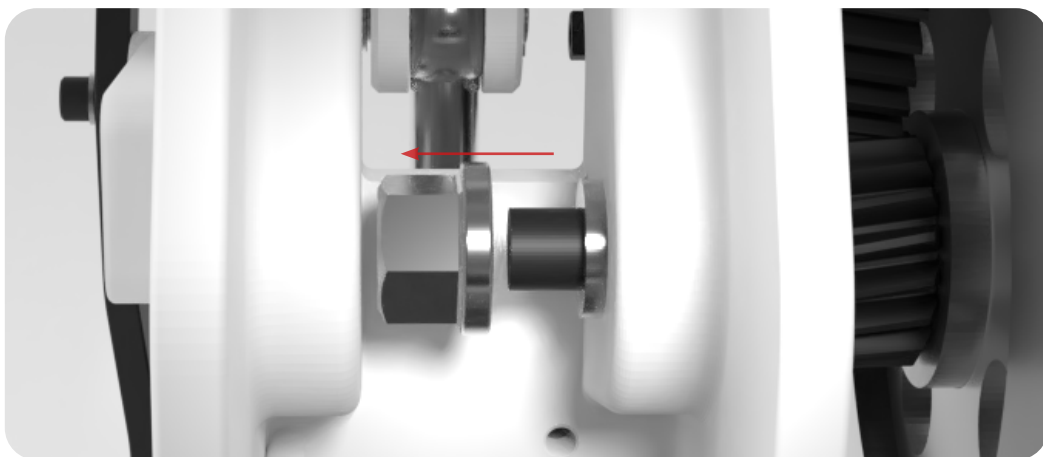

5. Unscrew the Pinion Gear Cam and remove the Pinion Gear from the Electrical Drive Flywheel.

5.1 Note: Use a gear pulley if the Pinion Gear is difficult to pry out.

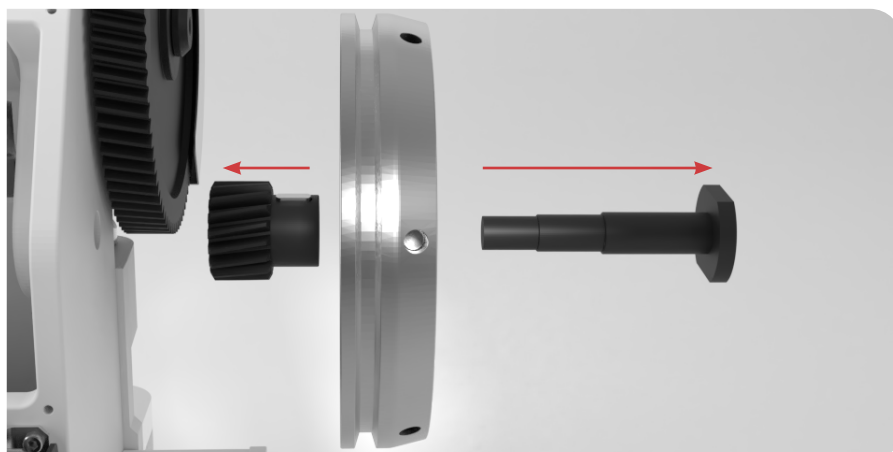

## Replace the Electrical Drive Flywheel

6. Insert the Pinion Gear and the Pinion Gear Cam into the new Electrical Drive Flywheel.

7. Install the Pinion Gear, the Pinion Gear Cam, and the new Electrical Drive Flywheel into the TDP 5<sup>®</sup> Base by tightening the Pinion Gear Cam's nut.

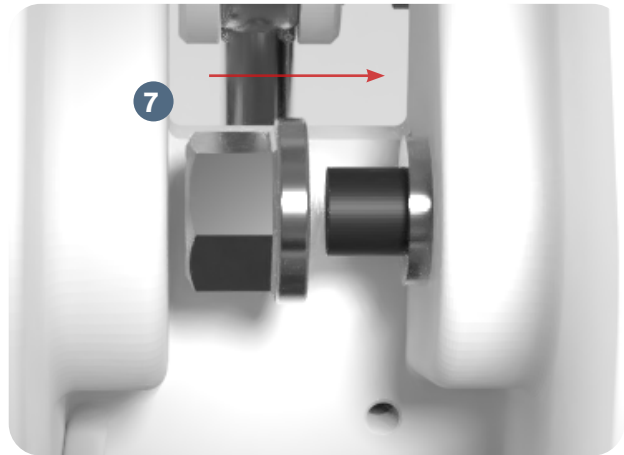
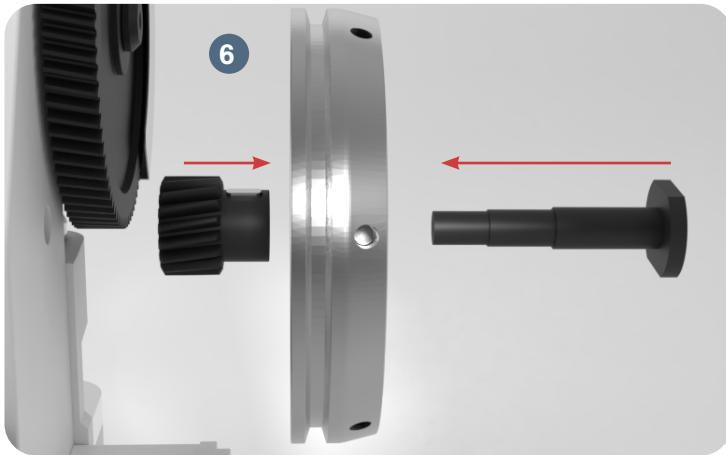

8. Reattach the Rear Enclosure Plate to the back of the TDP 5<sup>®</sup> with an Allen key.

9. Place the V Belt back onto the Drive Belt Pulley and the new Electrical Drive Flywheel.

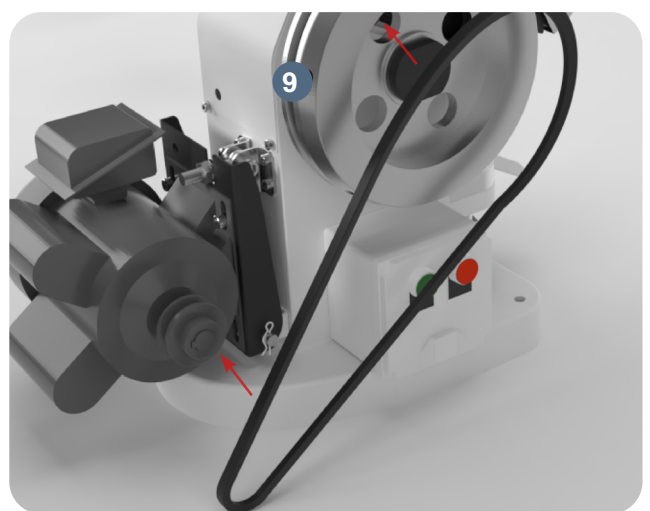
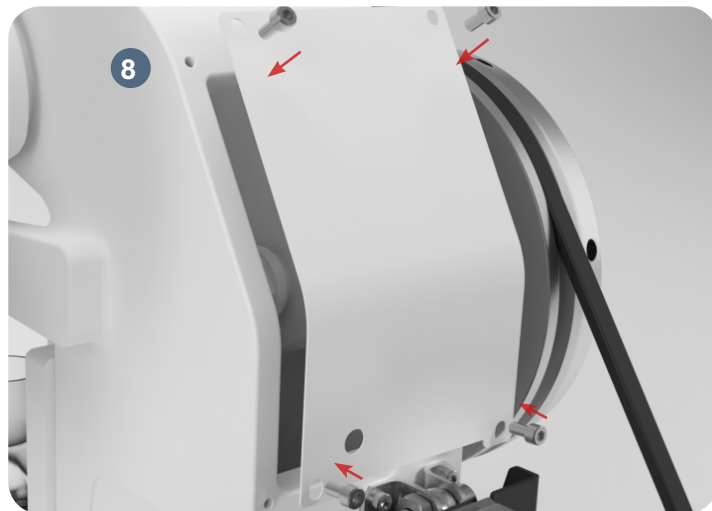

10. Adjust the nuts on the Motor Support Arm to tighten the V Belt.

10.1 Note: The further away the mount is from the TDP 5<sup>®</sup>, the tighter the V Belt's slack will be. The correct tension for the V Belt is [N] 94.42.

11. Turn the Hand Wheel for one rotation of the Top Cam Drive Shaft to ensure that the machine runs smoothly before plugging it in and turning it on.

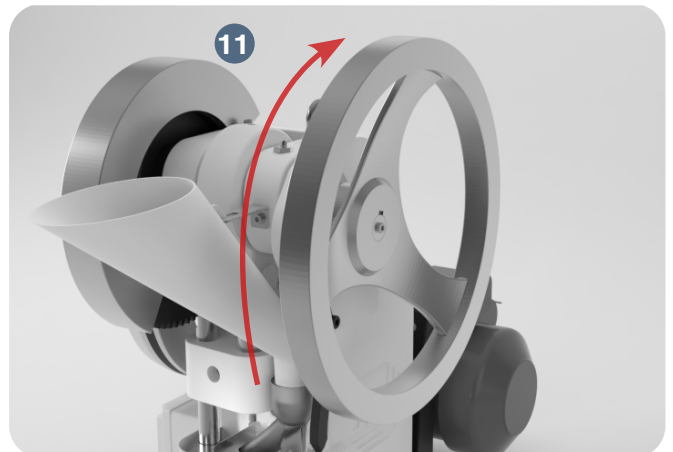
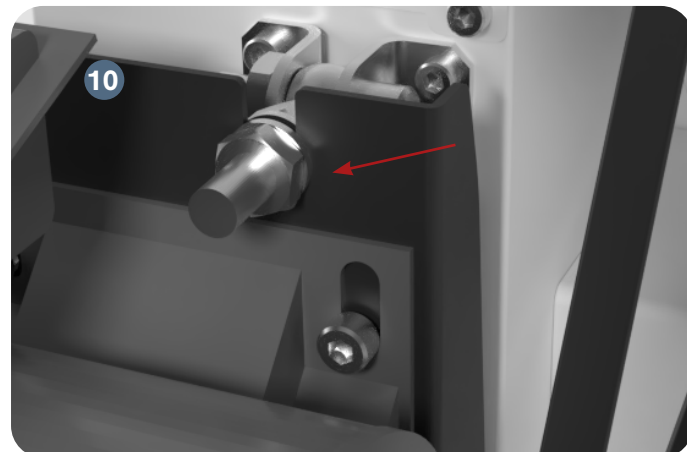

## Boot Timing Cam

Although this part lasts long, it can become worn over time. To replace the Boot Timing Cam, the Hand Wheel must be removed first.

### Tools and Materials Needed

- Heavy rubber mallet
- Set of metric Allen keys with ball ends
- 13 mm wrench
- New Boot Timing Cam part
- Disposable latex/rubber gloves (for food grade products and to protect hands from grease)
- Hairnet and/or beard net (food grade products only)
- Sterile shoe covers (food grade products only)



**WARNING:** To prevent any potential personal injury, ALWAYS unplug the TDP 5<sup>®</sup> from the electrical outlet when replacing parts.

### Instructions

Note: Wear latex/rubber gloves (and appropriate food grade attire if applicable) during this process.

#### Remove the Boot Timing Cam

1. Remove the Hopper carefully and catch any powder still inside of it.
2. Loosen the Hand Wheel Cap's bolt with an Allen key.
3. Disengage the Hand Wheel from the engraved key on the Top Cam Drive Shaft.
  - 3.1 Note: Use a rubber mallet if the Hand Wheel is difficult to remove.

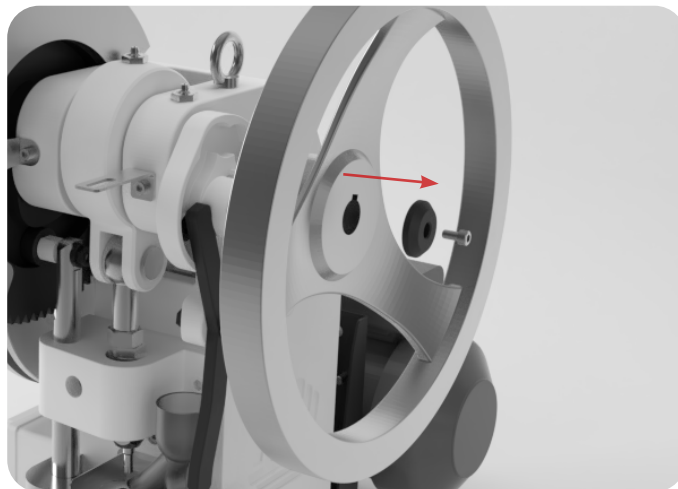



4. Loosen the Boot Timing Bar bolt's nuts with a wrench.
5. Loosen the Boot Timing Bar bolt with an Allen key.
6. Remove the Boot Timing Bar's end from the Boot.

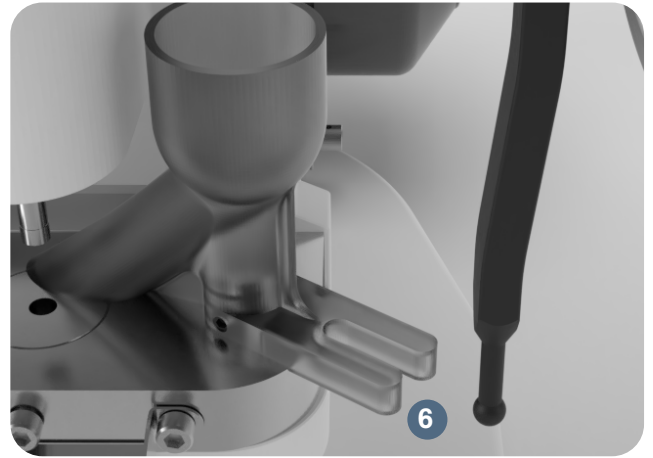
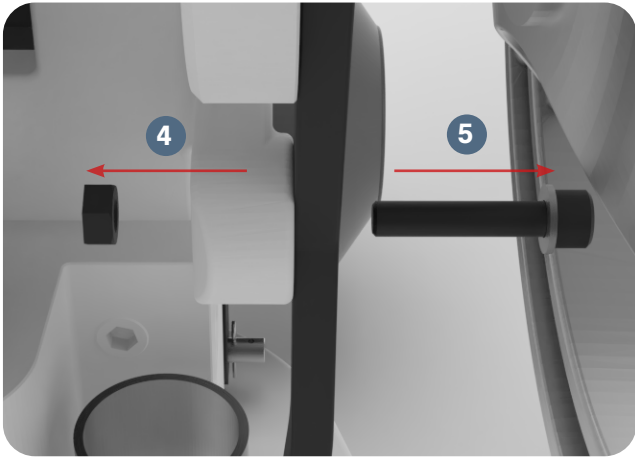

7. Gently hit the Boot Timing Cam with a rubber mallet to disengage it from the engraved key on the Top Cam Drive Shaft.

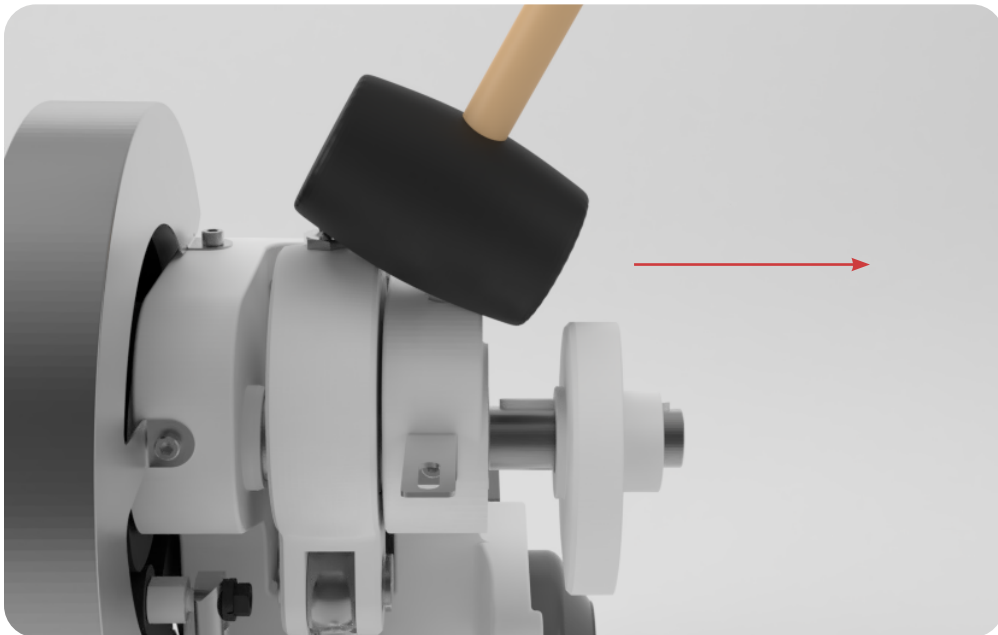



### Replace the Boot Timing Cam

8. Position the new Boot Timing Cam into the engraved key on the Top Cam Drive Shaft.
9. Place the Boot Timing Cam Runner on the Boot Timing Bar.
10. Insert the Boot Timing Bar with the runner into the side of the Boot Timing Cam.
11. Insert the Boot Timing Bar's end in the Boot
12. Tighten the Boot Timing Bar bolt with an Allen key.
13. Tighten the Boot Timing Bar bolt's nuts with a wrench.

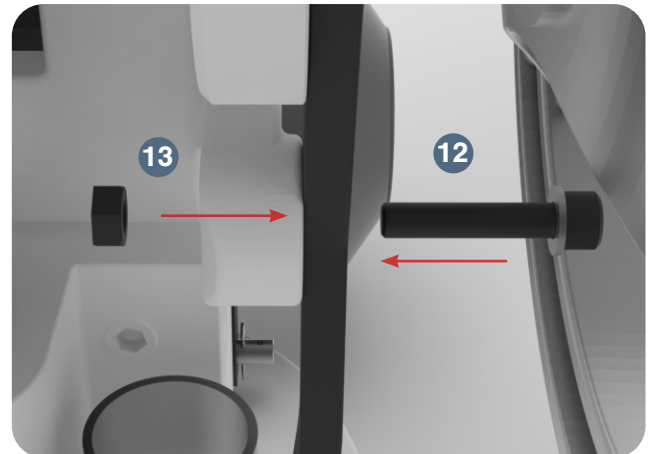
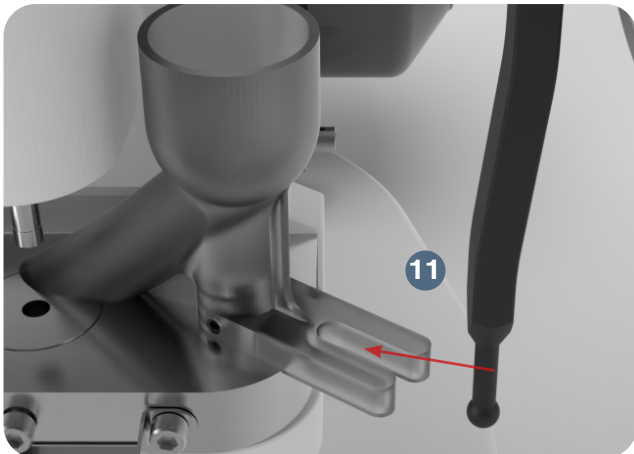
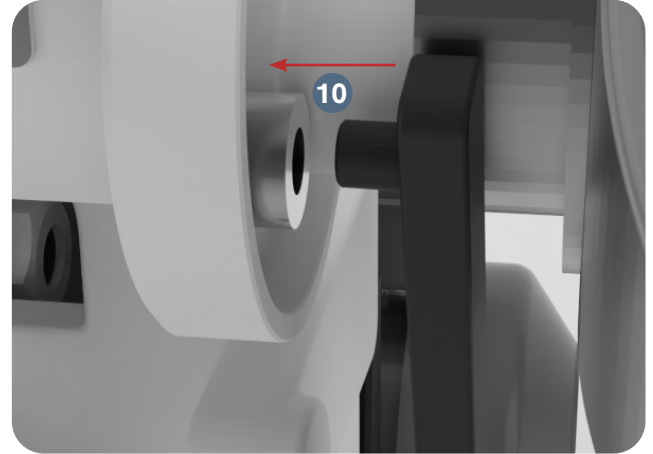
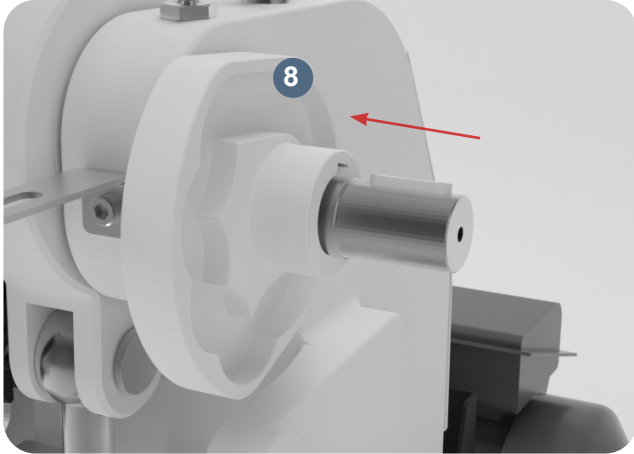

14. Position the Hand Wheel onto the engraved key on the new Top Cam Drive Shaft.
15. Tighten the Hand Wheel Cap and its bolt with an Allen key.

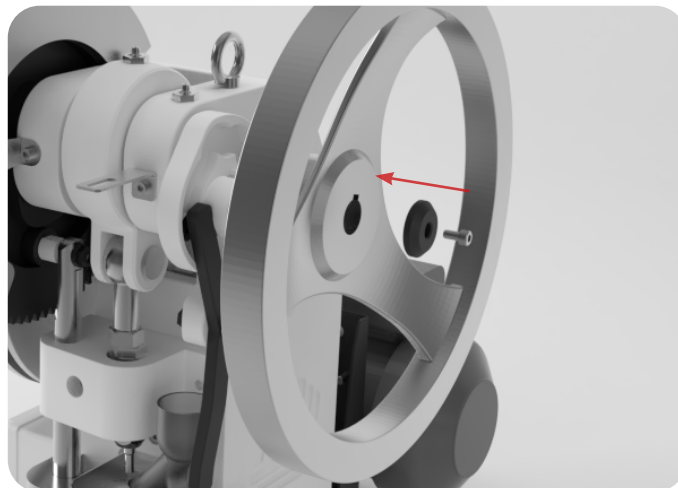

16. Reinsert the Hopper.

17. Turn the Hand Wheel for one rotation of the Top Cam Drive Shaft to ensure that the machine runs smoothly before plugging it in and turning it on.

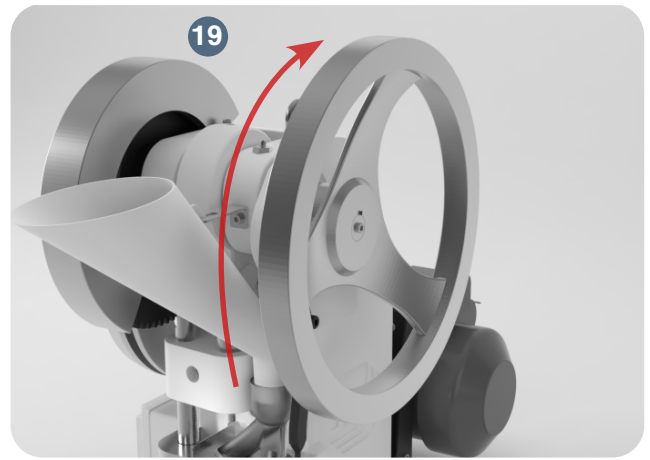
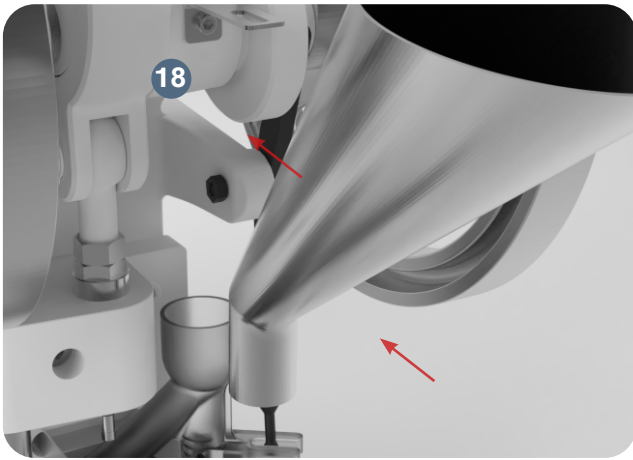

## Pinion Gear

Although this part rarely needs to be replaced, it can become worn out or have broken teeth due to a large amount of use. Like the Electrical Drive Flywheel, removal and replacement of this part may take a little physical effort on your part.

### Tools and Materials Needed

- Set of metric Allen keys with ball ends
- 19 mm wrench & 30 mm wrench
- Gear puller
- New Pinion Gear part
- Disposable latex/rubber gloves (for food grade products and to protect hands from grease)
- Hairnet and/or beard net (food grade products only)
- Sterile shoe covers (food grade products only)



**WARNING:** To prevent any potential personal injury, ALWAYS unplug the TDP 5<sup>®</sup> from the electrical outlet when replacing parts.

### Instructions

Note: Wear latex/rubber gloves (and appropriate food grade attire if applicable) during this process.

#### Remove the Pinion Gear

1. Adjust the nuts on the Motor Support Arm with a 19 mm wrench to loosen the V Belt.
  - 1.1 Note: The closer the Motor Mounting Plate is to the TDP 5<sup>®</sup>, the looser the V Belt's slack will be.

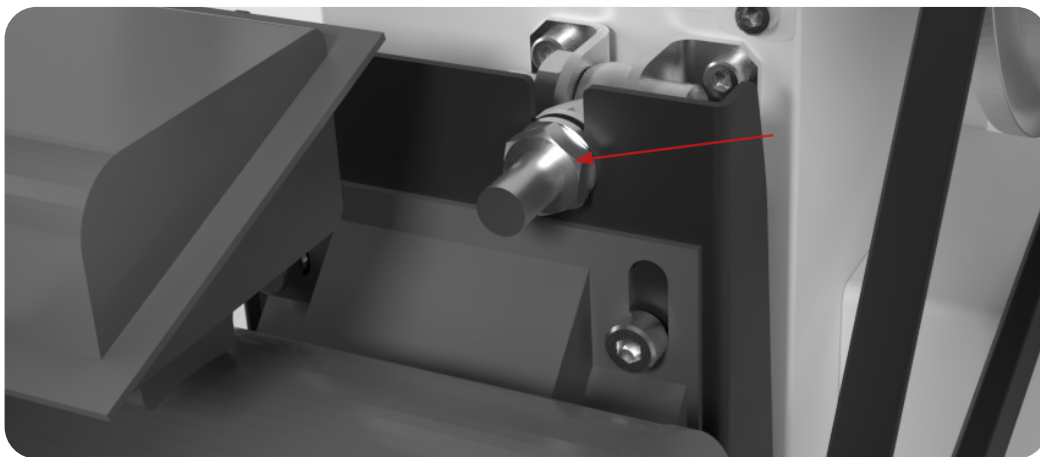

2. Remove the V Belt from the Drive Belt Pulley and the Electrical Drive Flywheel.

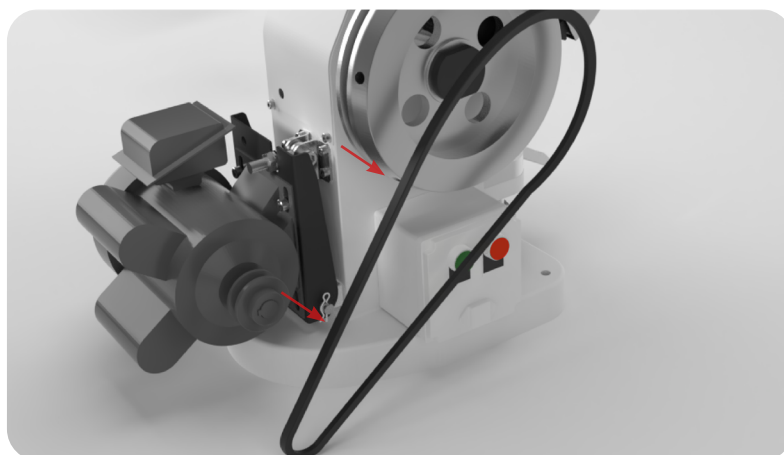

3. Remove the Rear Enclosure Plate from the back of the TDP 5<sup>®</sup> with an Allen key.



4. Loosen the nut from the Pinion Gear Cam that connects the Pinion Gear and the Electrical Drive Flywheel to the TDP 5<sup>®</sup> Base with a 30 mm wrench.

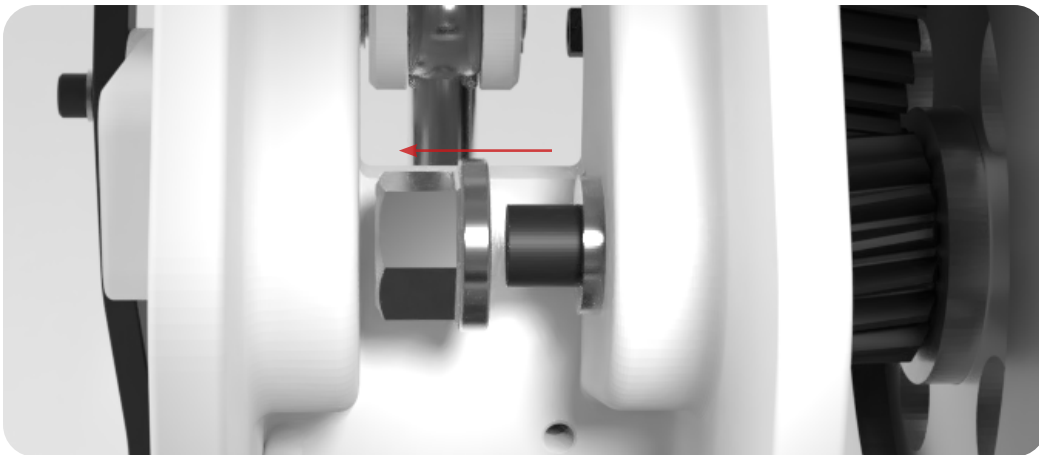

5. Unscrew the Pinion Gear Cam and remove the Pinion Gear from the Electrical Drive Flywheel.

5.1 Note: Use a gear puller if the Pinion Gear is difficult to pry out.

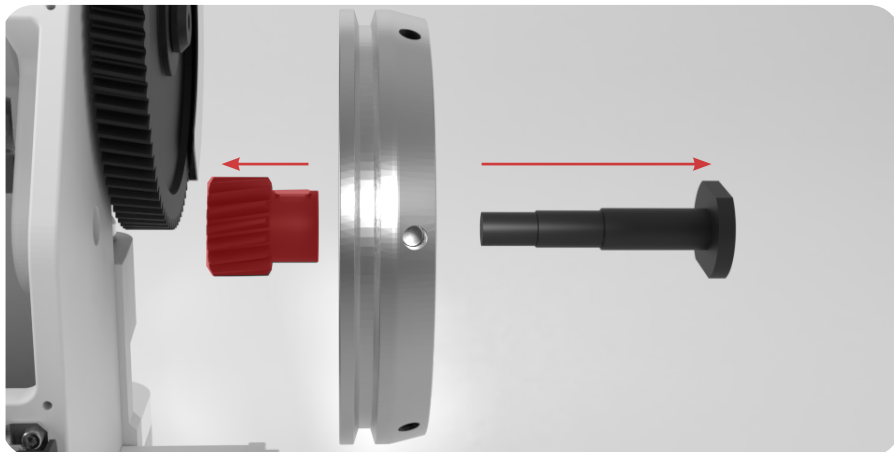

## Replace the Pinion Gear

6. Insert the new Pinion Gear and the Pinion Gear Cam into the Electrical Drive Flywheel.

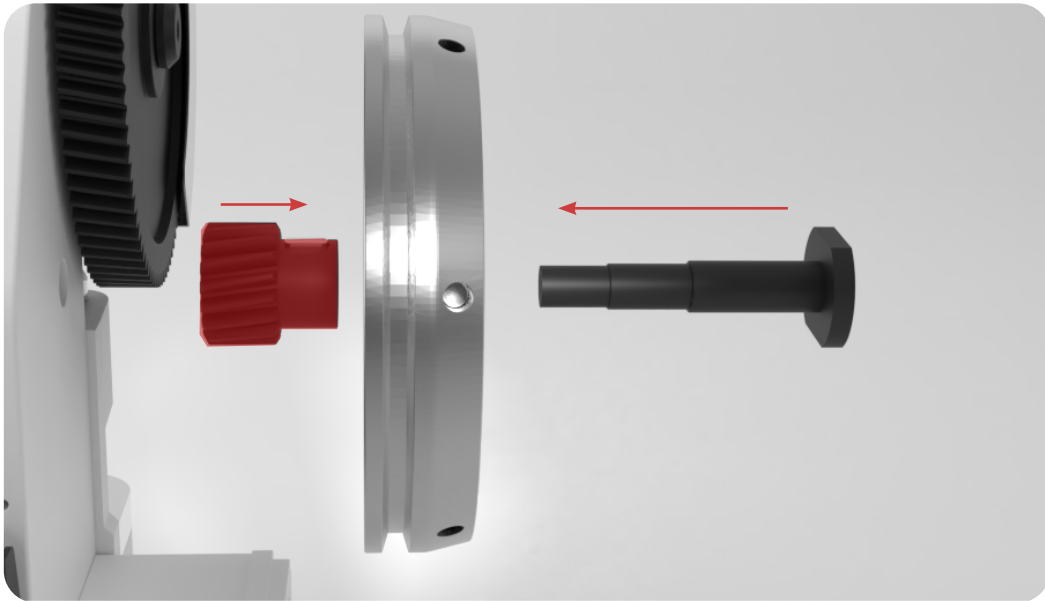

7. Install the new Pinion Gear, the Pinion Gear Cam, and the Electrical Drive Flywheel into the TDP 5<sup>®</sup> Base.

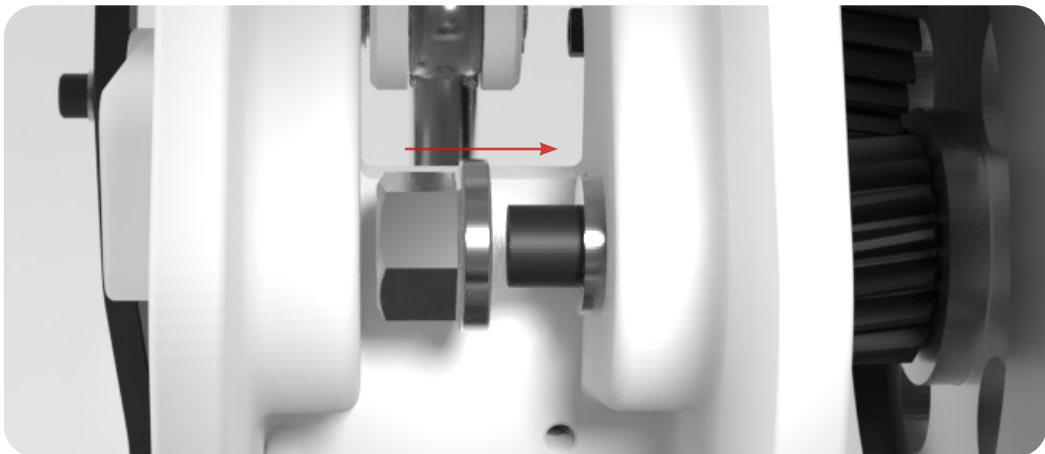

8. Reattach the Rear Enclosure Plate to the back of the TDP 5<sup>®</sup> with an Allen key.

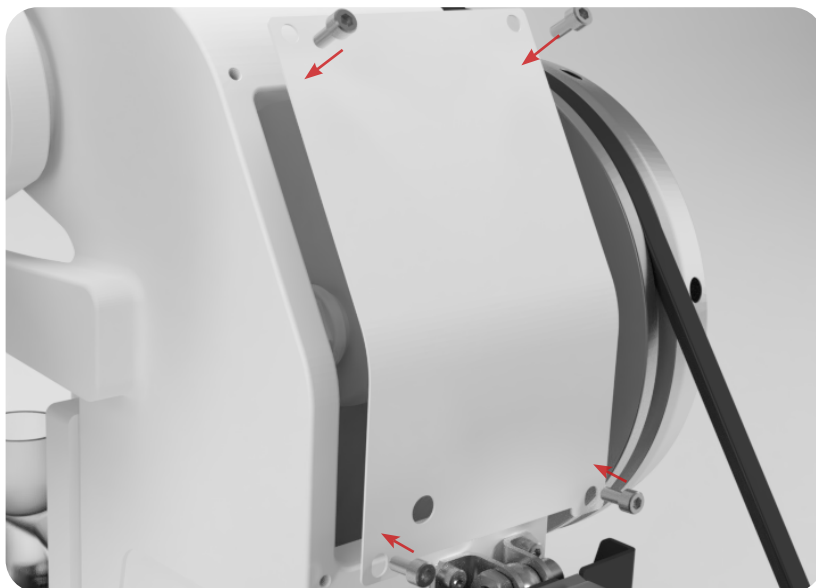

9. Place the V Belt back onto the Drive Belt Pulley and the Electrical Drive Flywheel.

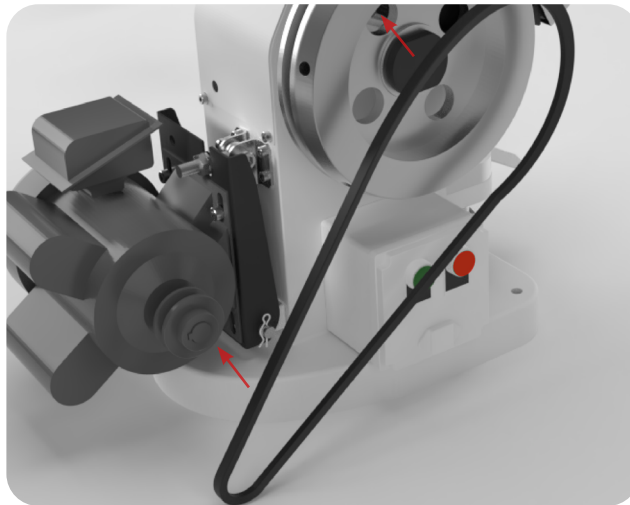

10. Adjust the nuts on the Motor Support Arm to tighten the V Belt.

10.1 Note: The further away the mount is from the TDP 5<sup>®</sup>, the tighter the V Belt's slack will be. The correct tension for the V Belt is [N] 94.42.

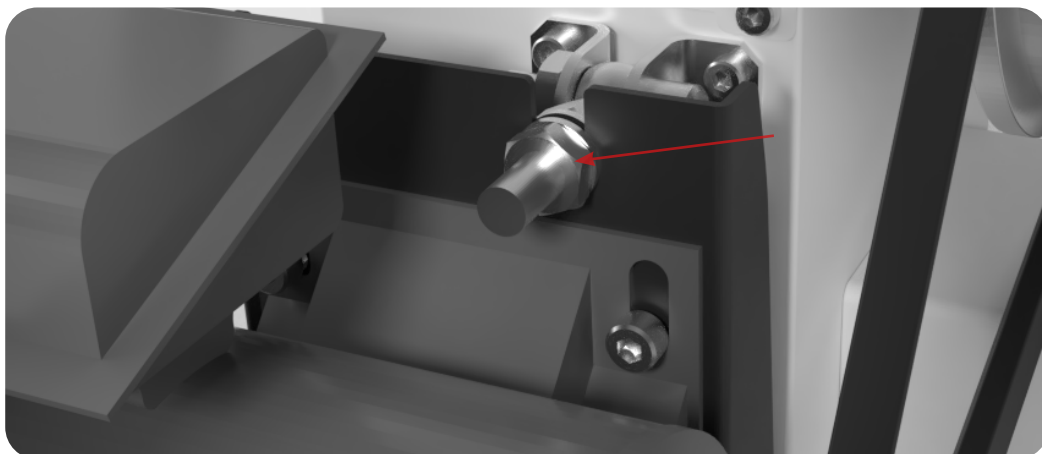

11. Turn the Hand Wheel for one rotation of the Top Cam Drive Shaft to ensure that the machine runs smoothly before plugging it in and turning it on.

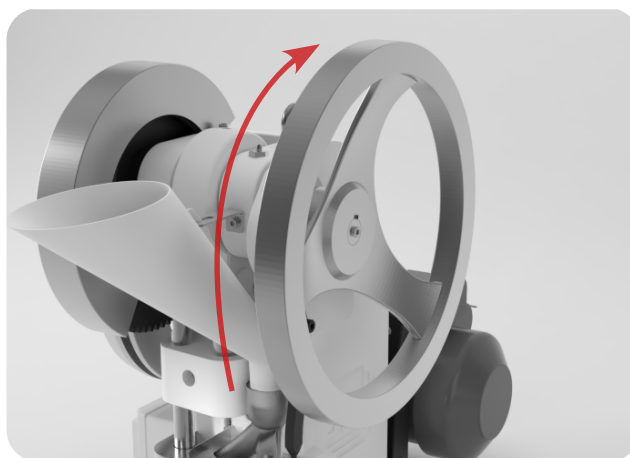

## Cam Drive Cog

Much similar to the Pinion Gear, the rare repair needed for this part is whenever the teeth are worn down due to a large amount of use.

### Tools and Materials Needed

- Set of metric Allen keys with ball ends
- 19 mm & 30 mm wrench
- Gear puller
- New Cam Drive Cog part
- Disposable latex/rubber gloves (for food grade products and to protect hands from grease)
- Hairnet and/or beard net (food grade products only)
- Sterile shoe covers (food grade products only)



**WARNING:** To prevent any potential personal injury, ALWAYS unplug the TDP 5<sup>®</sup> from the electrical outlet when replacing parts.

### Instructions

Note: Wear latex/rubber gloves (and appropriate food grade attire if applicable) during this process.

#### Remove the Cam Drive Cog

1. Adjust the nuts on the Motor Support Arm with a 19 mm wrench to loosen the V Belt.
  - 1.1 Note: The closer the Motor Mounting Plate is to the TDP 5<sup>®</sup>, the looser the V Belt's slack will be.

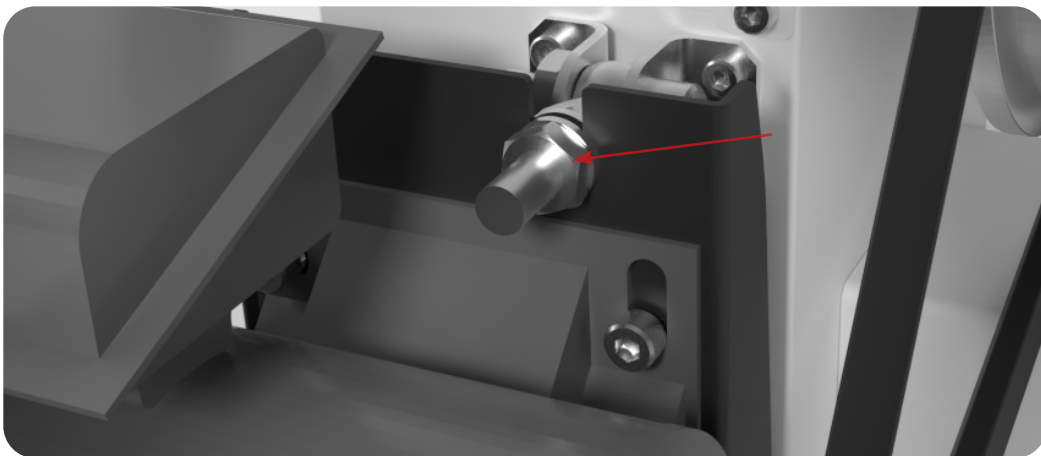

2. Remove the V Belt from the Drive Belt Pulley and the Electrical Drive Flywheel.

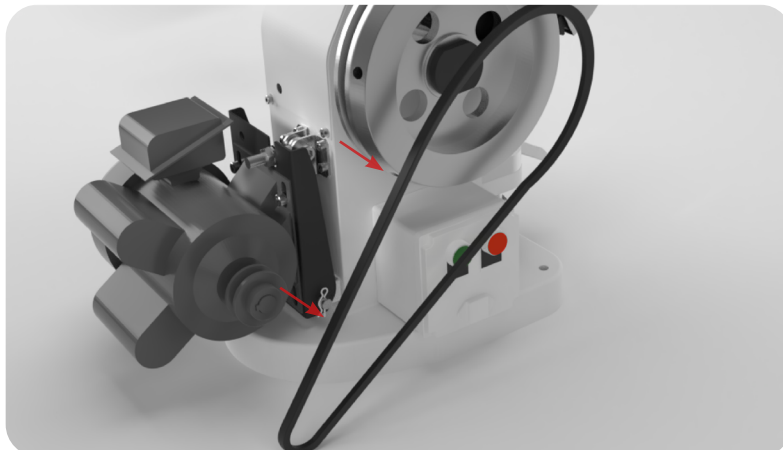



3. Remove the Rear Enclosure Plate from the back of the TDP 5<sup>®</sup> with an Allen key.



4. Loosen the nut from the Pinion Gear Cam that connects the Pinion Gear and the Electrical Drive Flywheel to the TDP 5<sup>®</sup> Base with a 30 mm wrench.

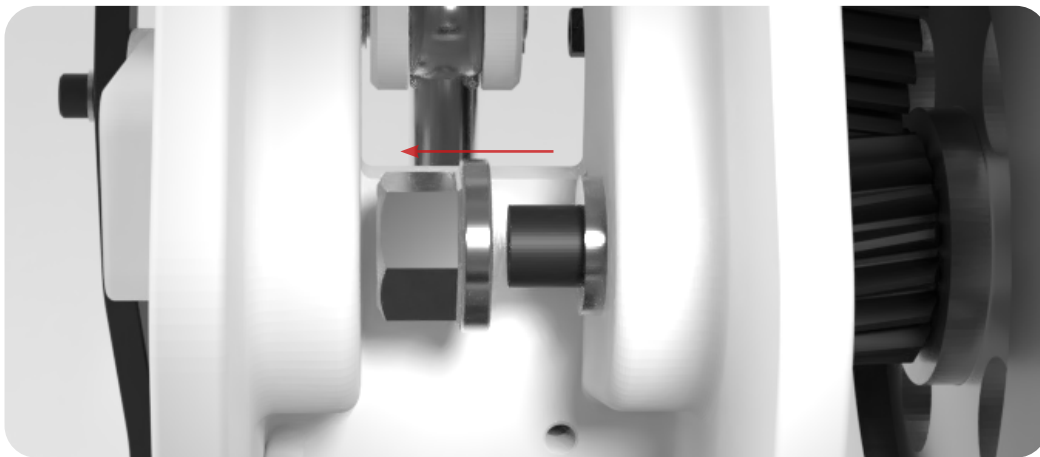

5. Unscrew the Pinion Gear Cam and remove the Pinion Gear from the Electrical Drive Flywheel.

5.1 Note: Use a gear puller if the Pinion Gear is difficult to pry out.

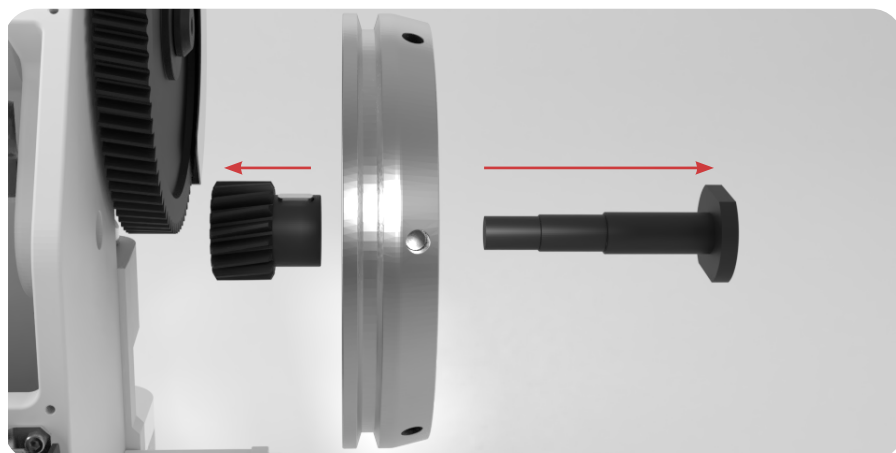



### Remove the Cam Drive Cog

6. Remove the Cam Drive Cog Safety Cover with an Allen key.
7. Remove the Cam Drive Cog Cap from the Cam Drive Cog with an Allen key.
8. Disengage the Cam Drive Cog from the engraved key on the Top Cam Drive Shaft.

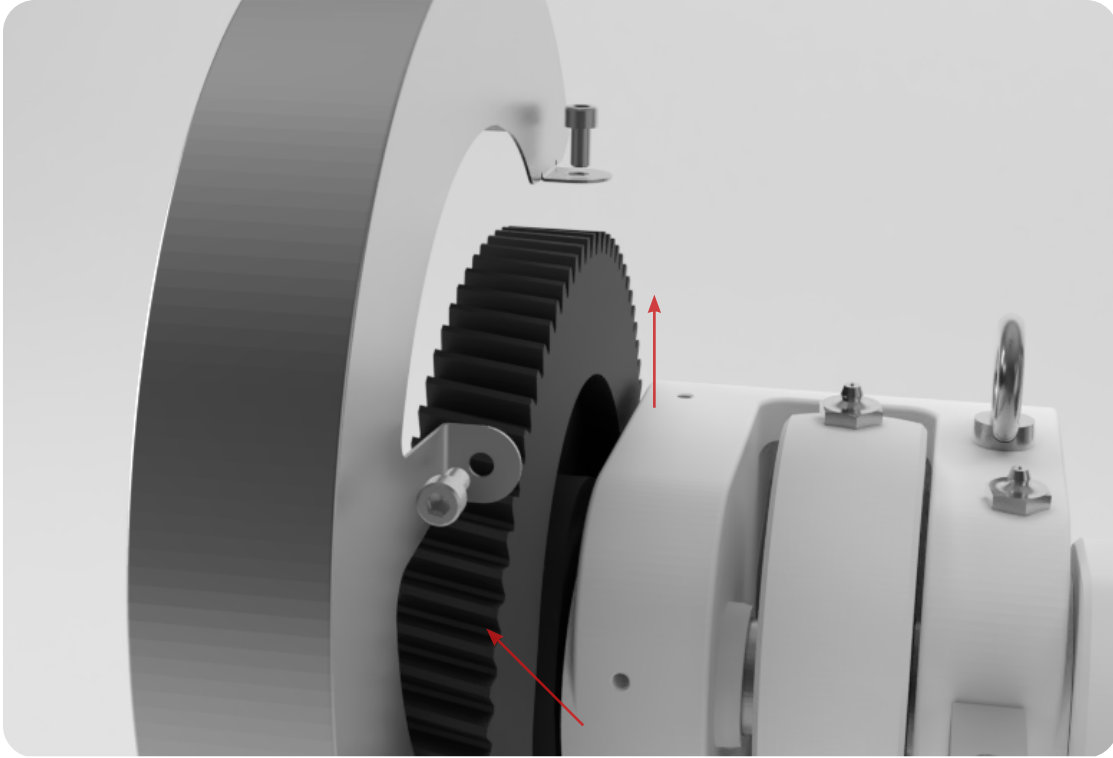

9. Remove the Cam Drive Cog Cap from the Cam Drive Cog with an Allen key.
10. Disengage the Cam Drive Cog from the engraved key on the Top Cam Drive Shaft.

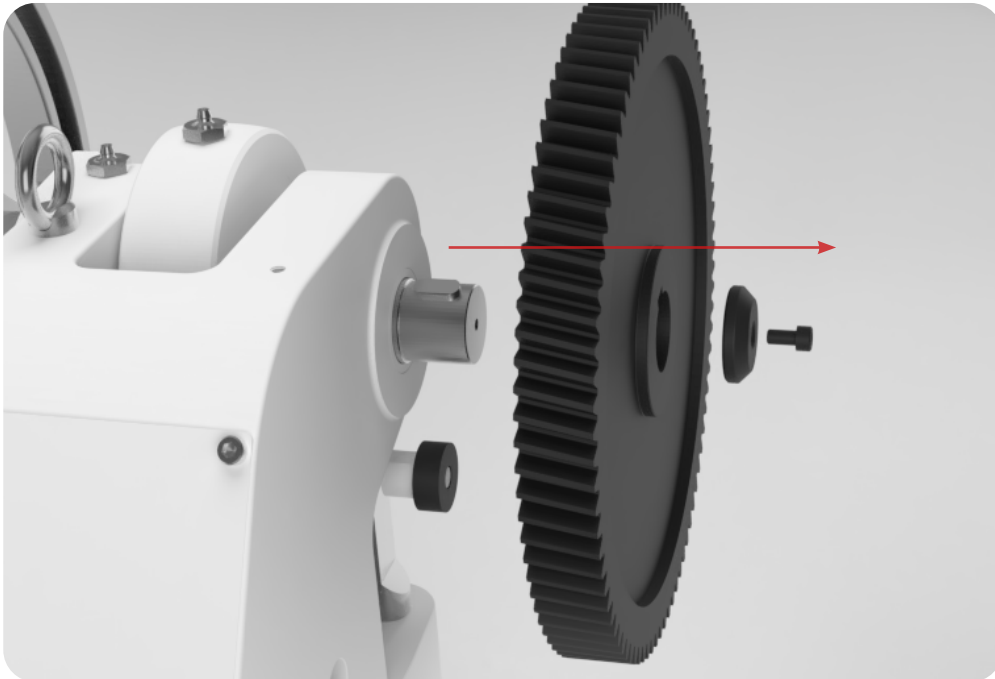

## Replace the Cam Drive Cog

9. Insert the new Cam Drive Cog onto the engraved key on the Top Cam Drive Shaft.
10. Reinsert the Cam Drive Cog Cap on the new Cam Drive Cog with an Allen key.
11. Resecure the Cam Drive Cog Safety Cover over the new Cam Drive Cog with an Allen key.

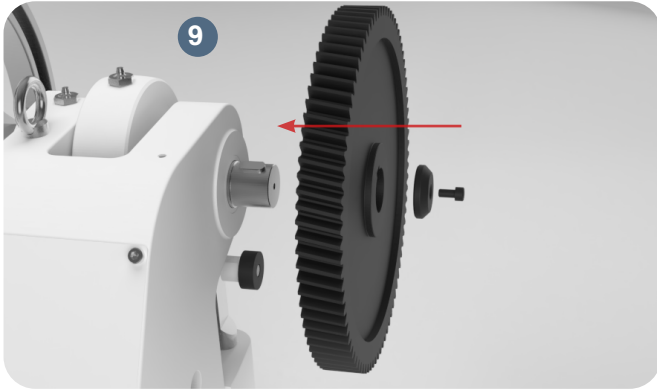

12. Insert the Pinion Gear and the Pinion Gear Cam into the Electrical Drive Flywheel.
13. Install the Pinion Gear, the Pinion Gear Cam, and the Electrical Drive Flywheel into the TDP 5<sup>®</sup> Base.

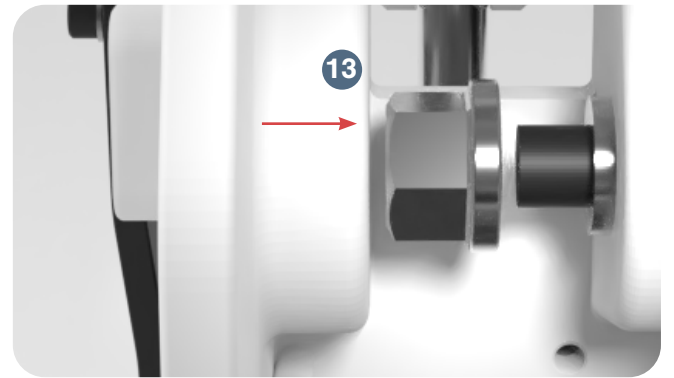
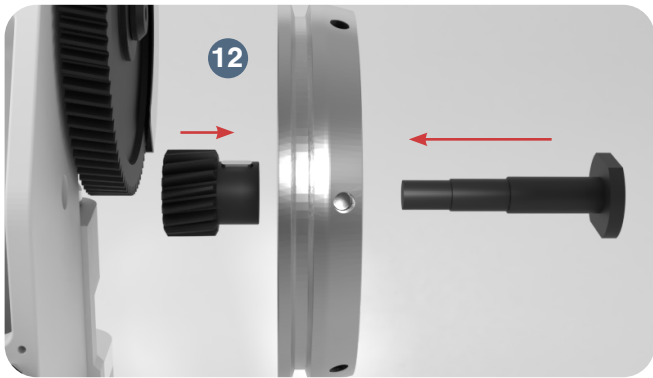

14. Reattach the Rear Enclosure Plate to the back of the TDP 5<sup>®</sup> with an Allen key.
15. Place the V Belt back onto the Drive Belt Pulley and the Electrical Drive Flywheel.

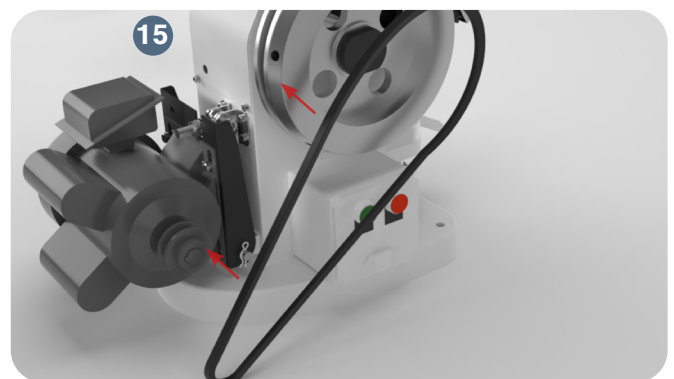

16. Adjust the nuts on the Motor Support Arm to tighten the V Belt.

16.1 Note: The further away the mount is from the TDP 5<sup>®</sup>, the tighter the V Belt's slack will be. The correct tension for the V Belt is [N] 94.42.

17. Turn the Hand Wheel for one rotation of the Top Cam Drive Shaft to ensure that the machine runs smoothly before plugging it in and turning it on.

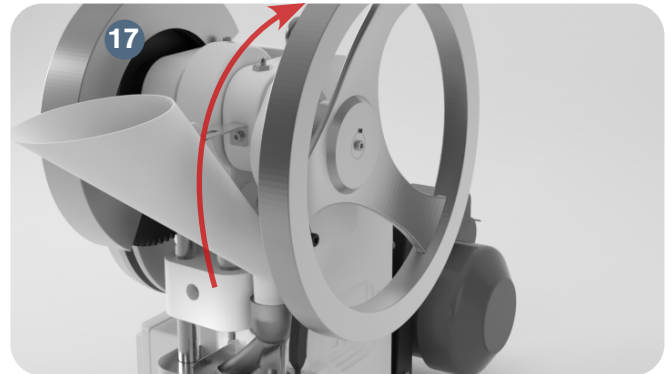
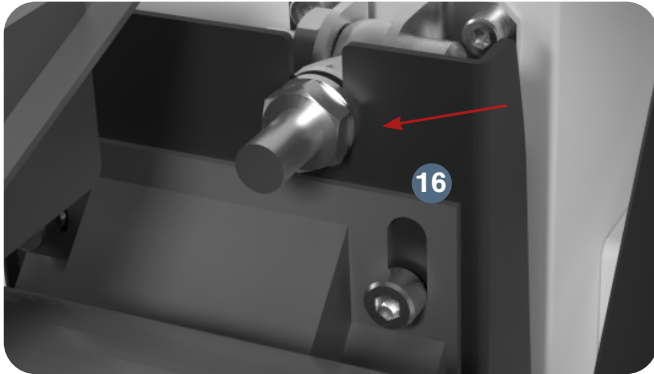

## Drive Belt Pulley

The Drive Belt Pulley is attached to the motor, which drives the V Belt to move the Cam Drive Cog.

### Tools and Materials Needed

- 19 mm wrench
- Gear puller
- New Drive Belt Pulley part
- Disposable latex/rubber gloves (for food grade products and to protect hands from grease)
- Hairnet and/or beard net (food grade products only)
- Sterile shoe covers (food grade products only)



**WARNING:** To prevent any potential personal injury, ALWAYS unplug the TDP 5<sup>®</sup> from the electrical outlet when replacing parts.

### Instructions

Note: Wear latex/rubber gloves (and appropriate food grade attire if applicable) during this process.

#### Remove the Drive Belt Pulley

1. Adjust the nuts on the Motor Support Arm with a 19 mm wrench to loosen the V Belt.
  - 1.1 Note: The closer the Motor Mounting Plate is to the TDP 5<sup>®</sup>, the looser the V Belt's slack will be.
2. Remove the V Belt from the Drive Belt Pulley and the Electrical Drive Flywheel.
3. Disengage the Drive Belt Pulley from the engraved key on the Motor with a gear puller.

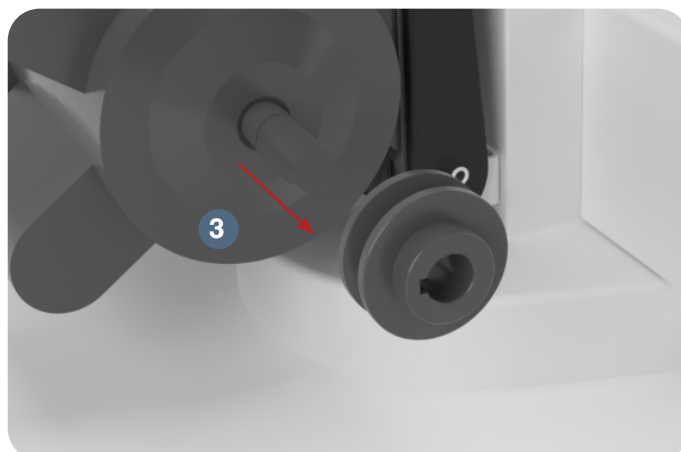
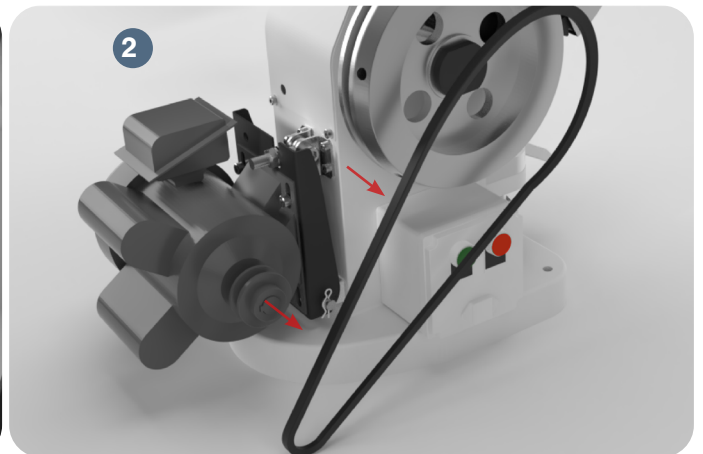
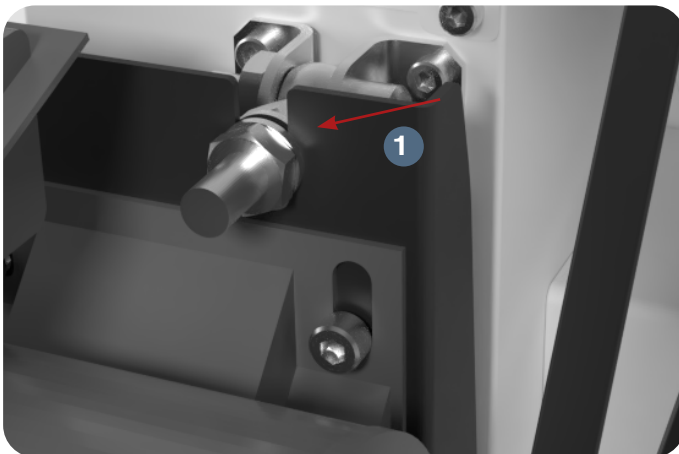

## Replace the Drive Belt Pulley

4. Place the new Drive Belt Pulley into the engraved key on the Motor.

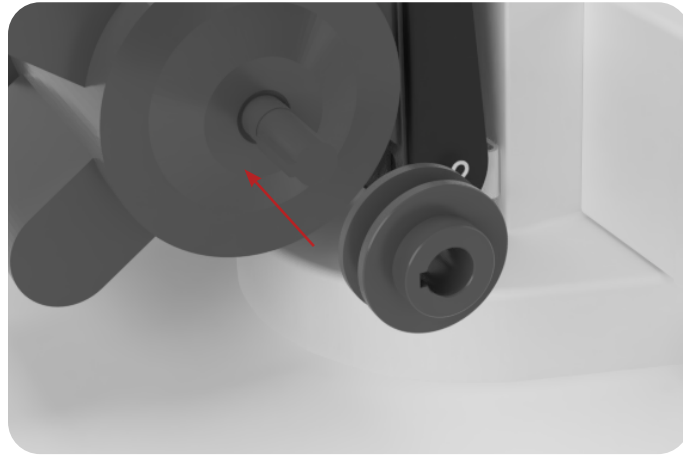

5. Place the V Belt onto the new Drive Belt Pulley and the Electrical Drive Flywheel.

6. Adjust the nuts on the Motor Support Arm to tighten the V Belt.

6.1 Note: The further away the Motor Mounting Plate is from the TDP 5®, the tighter the V Belt's slack will be. The correct tension for the V Belt is [N] 94.42.

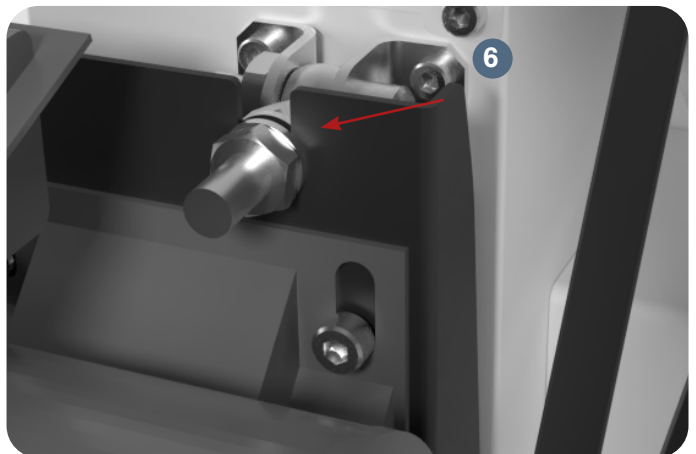
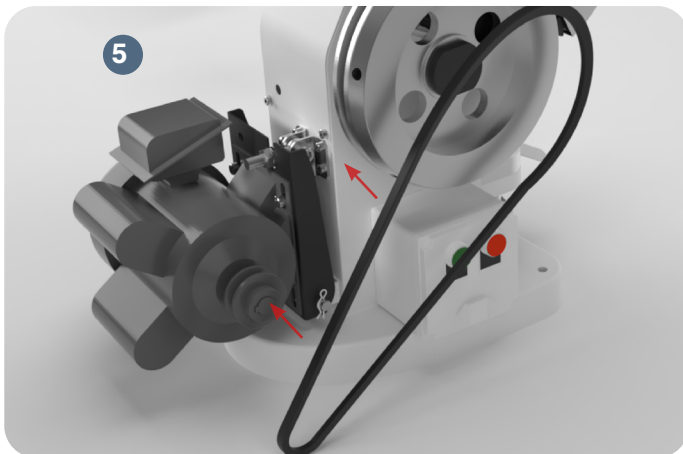

7. Turn the Hand Wheel for one rotation of the Top Cam Drive Shaft to ensure that the machine runs smoothly before plugging it in and turning it on.

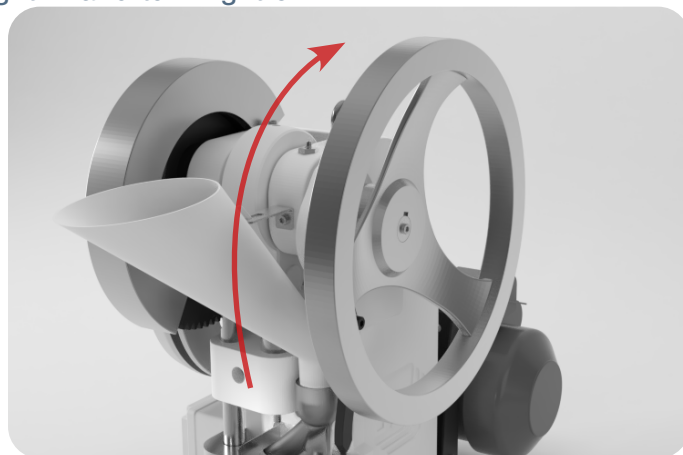

## Motor

Much similar to the Pinion Gear, the rare repair needed for this part is whenever the teeth are worn down due to a large amount of use.

### Tools and Materials Needed

- 19 mm wrench
- Crosshead screwdriver
- Set of metric Allen keys with ball ends
- Disposable latex/rubber gloves (for food grade products and to protect hands from grease)
- Hairnet and/or beard net (food grade products only)
- Sterile shoe covers (food grade products only)



**WARNING:** If you do not have sufficient experience in wiring electrical items, do NOT attempt to replace this part at the risk of electrical shock.

**Turn off and unplug the machine before replacing this part.**



The TDP 5<sup>®</sup> motor is quite heavy. Be sure to have a firm hold on this part while you are removing the connecting bolts to prevent it from falling and possibly causing personal injury.

### Instructions

Note: Wear latex/rubber gloves (and appropriate food grade attire if applicable) during this process.

#### Remove the Motor

1. Remove the nut on the Motor Support Arm with a 19 mm wrench and take off the V Belt.
2. Remove the V Belt from the Drive Belt Pulley and the Electrical Drive Flywheel.

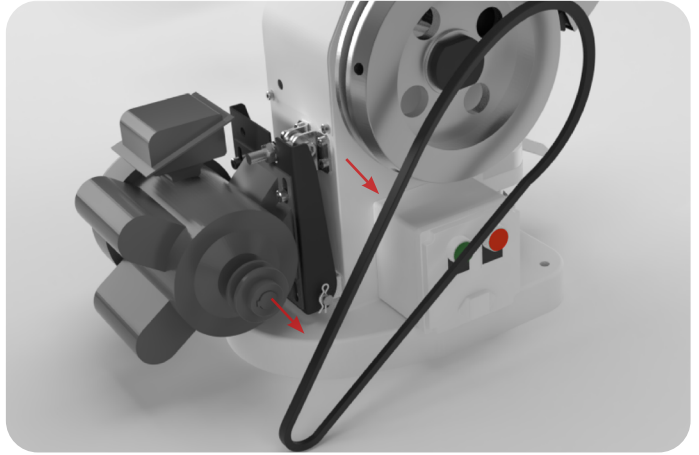
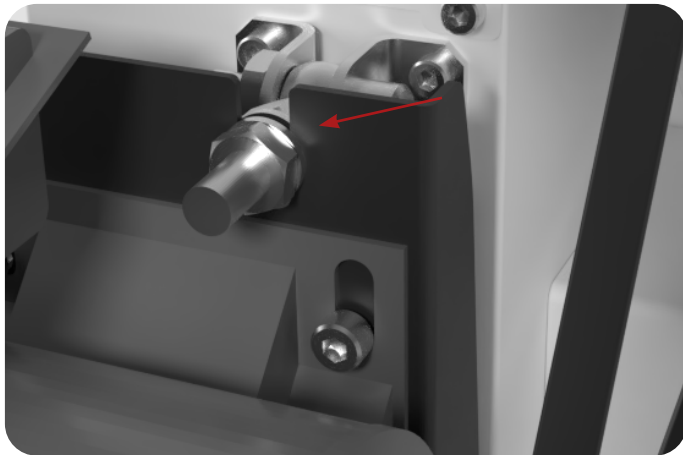

3. Remove the four connecting bolts from the Motor Mounting Plate with a wrench.

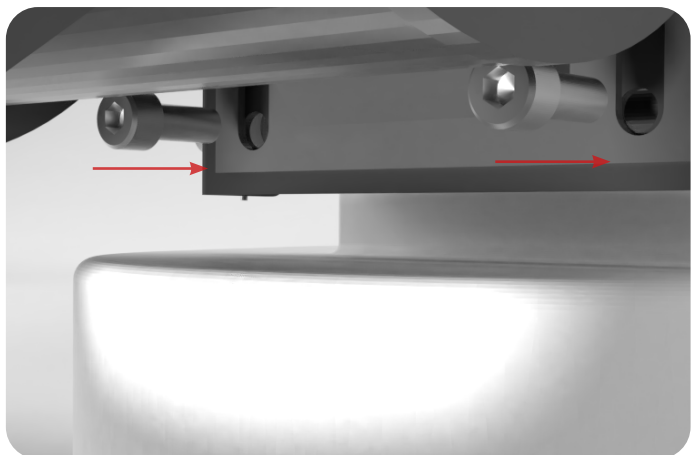
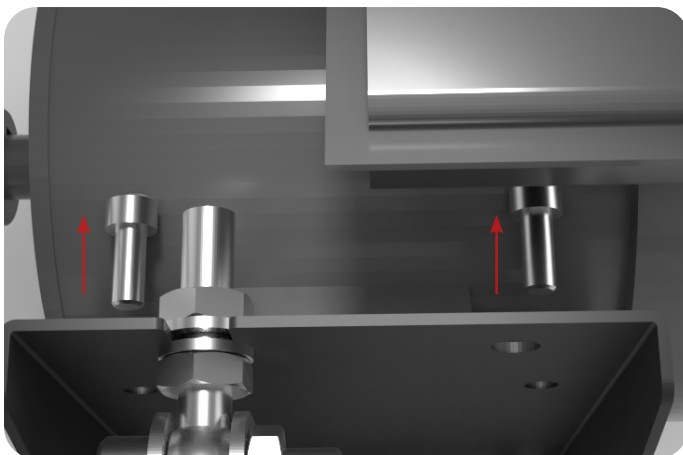



4. Remove the Drive Belt Pulley from the Motor with a gear puller.

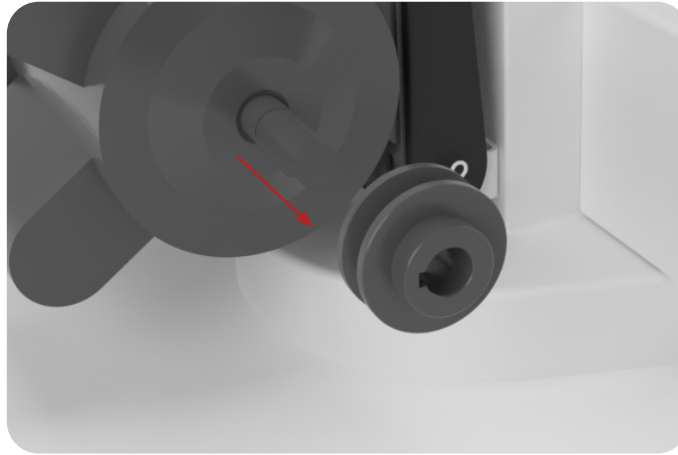

5. Open the Motor's wiring box with a crosshead screwdriver.

6. Remove the Electrical Box's wires from the Motor with a crosshead screwdriver to free the Motor from the TDP 5®.



6.1 Note: if the wiring in your Motor is different, take a picture to use it as a reference later.

## Replace the Motor

7. Position the new Motor behind the TDP 5<sup>®</sup> and the Motor Mounting Plate.

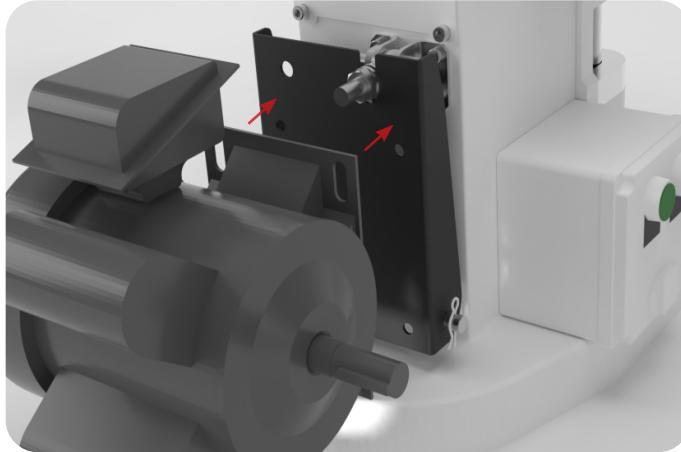

8. Insert the four bolts through the Motor Mounting Plate and into the Motor and tighten their nuts with a wrench.

9. Reinsert the Motor Support Arm into the Motor Mounting Plate and loosely tighten its nut with a 19 mm wrench.

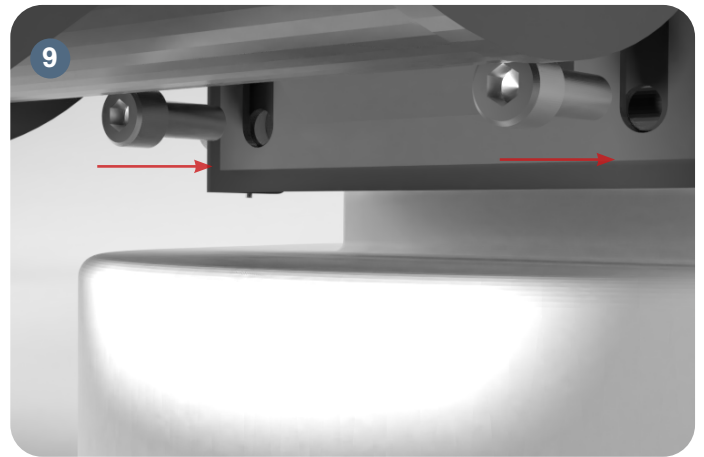
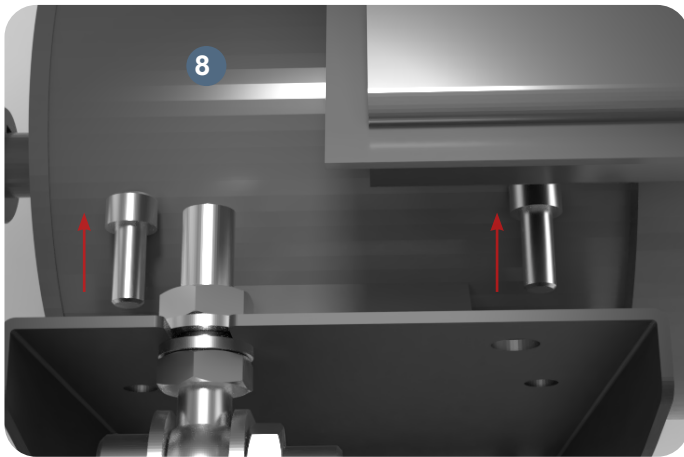

10. Screw in the Electrical Box's wires in the appropriate position with a crosshead screwdriver.

10.1 Note: Refer to step #6's photo or the picture you took of your motor's wiring.

11. Close the new Motor's wiring box with a crosshead screwdriver.



12. Insert the Drive Belt Pulley on the new Motor.

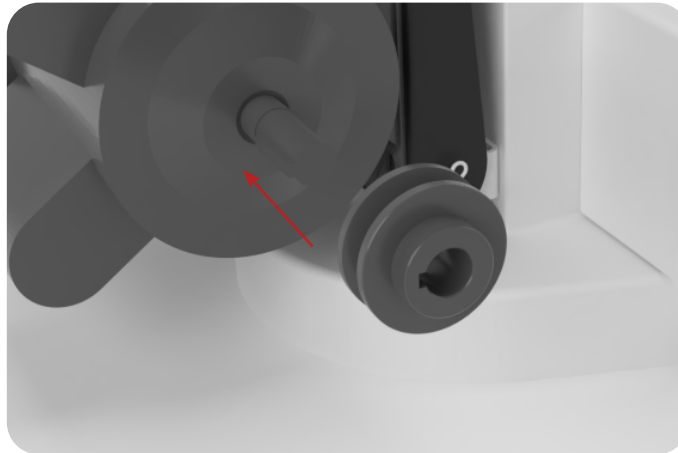

13. Place the V Belt onto the Drive Belt Pulley and the Electrical Drive Flywheel.

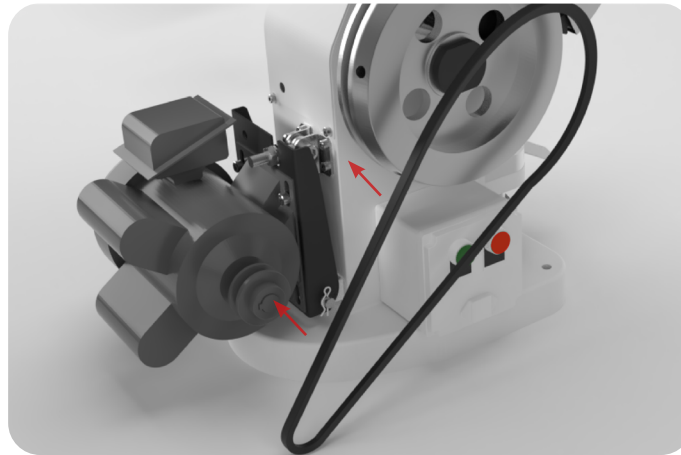

14. Adjust the nuts on the Motor Mounting Plate to tighten the V Belt.

14.1 Note: The further away the Motor Mounting Plate is from the TDP 5<sup>®</sup>, the tighter the Belt's slack will be. The correct tension for the V Belt is [N] 94.42.

15. Turn the Hand Wheel for one rotation of the Top Cam Drive Shaft to ensure that the machine runs smoothly before plugging it in and turning it on.

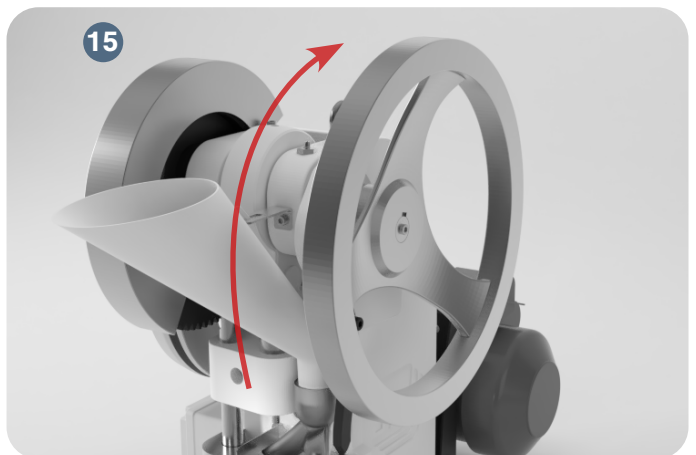
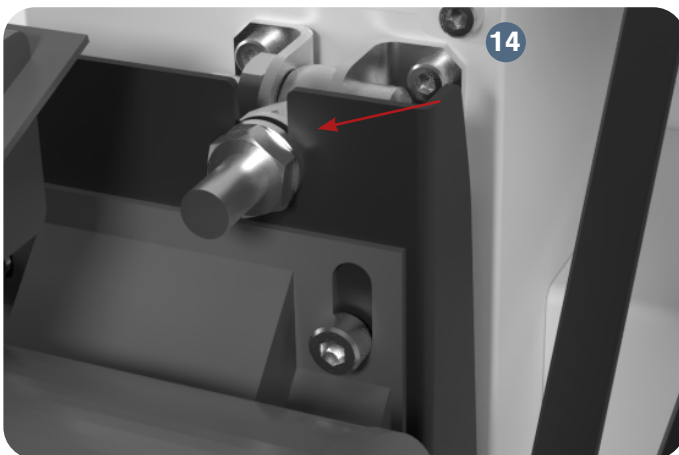

## Top Cam Drive Shaft

The Top Cam Drive Shaft drives many important parts in the TDP 5®'s upper assembly. These instructions explain how to remove and replace the Top Cam Drive Shaft, which involves the removal and replacement of all the other parts driven by it.

Please note that this contains abridged steps that direct you to other instructions found in this manual. If you need additional assistance, please refer to those detailed instructions.

### Tools and Materials Needed

- Rubber mallet
- Set of metric Allen keys with ball ends
- 13 mm, 19 mm, 24 mm (2), & 30 mm wrenches
- Gear puller
- Circlip pliers
- Copper pipe around 22 mm in diameter
- New Top Cam Drive Shaft part
- Disposable latex/rubber gloves (for food grade products and to protect hands from grease)
- Hairnet and/or beard net (food grade products only)
- Sterile shoe covers (food grade products only)



**WARNING:** To prevent any potential personal injury, ALWAYS unplug the TDP 5® from the electrical outlet when replacing parts.

**CAUTION:** This part should only be replaced by experienced mechanics, engineers, or individuals who have a lot of experience with the TDP 5®. Gently tap the Top Cam Drive Shaft to avoid damaging parts.

### Instructions

Note: Wear latex/rubber gloves (and appropriate food grade attire if applicable) during this process.

#### Remove the Top Cam Drive Shaft

1. Remove the Hopper carefully and catch any powder still inside of it.
2. Remove the Ejection Tray with an Allen key.

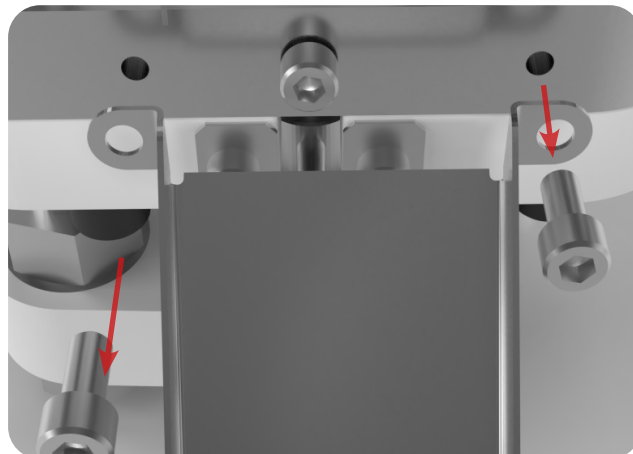

3. Remove the Boot Timing Bar and Boot.

3.1 Note: Please refer to the repair Boot Timing Bar instructions on page 39 and repair Boot instructions on page 42 for further assistance.

4. Remove the V Belt.

4.1 Note: Please refer to the repair V Belt instructions on page 69 for further assistance.

5. Remove the Electrical Drive Flywheel, Pinion Gear, and Cam Drive Cog.

5.1 Note: Please refer to the repair Cam Drive Cog instructions on page 83 for further assistance.

6. Remove the Upper Punch, Upper Drift Pin Assembly, and Upper Drift Pin Assembly Rod Eye and Clevis.

6.1 Note: Please refer to the repair Upper Drift Pin Assembly Rod Eye and Clevis instructions on page 51 for further assistance.

7. Loosen the Hand Wheel Cap's bolt with an Allen key.

8. Disengage the Hand Wheel from the engraved key on the Top Cam Drive Shaft.

8.1 Note: Use a rubber mallet if the Hand Wheel is difficult to remove.

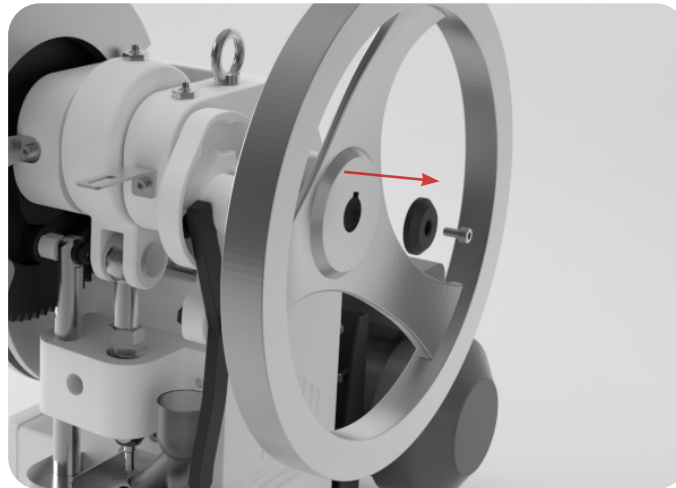

9. Hold the copper pipe at the Top Cam Drive Shaft shaft's end that is furthest away from the Boot Timing Cam.

10. Gently tap the copper pipe against the Top Cam Drive Shaft with a rubber mallet to move it through the TDP 5's Base.

11. Continue to tap the Top Cam Drive Shaft with the copper pipe and rubber mallet until the Eccentric Sheave and Eccentric Sheave Strap disengage.

11.1 Note: Be sure to catch these parts before they completely disengage.

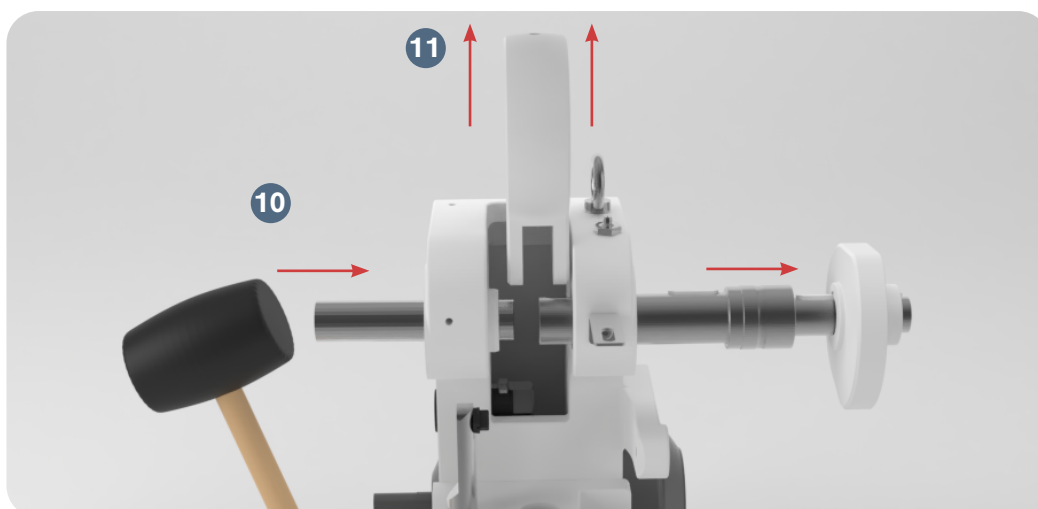

12. Disengage the Boot Timing Cam from the Top Cam Drive Shaft's engraved key.  
12.1 Note: Use a rubber mallet if the Boot Timing Cam is difficult to remove.

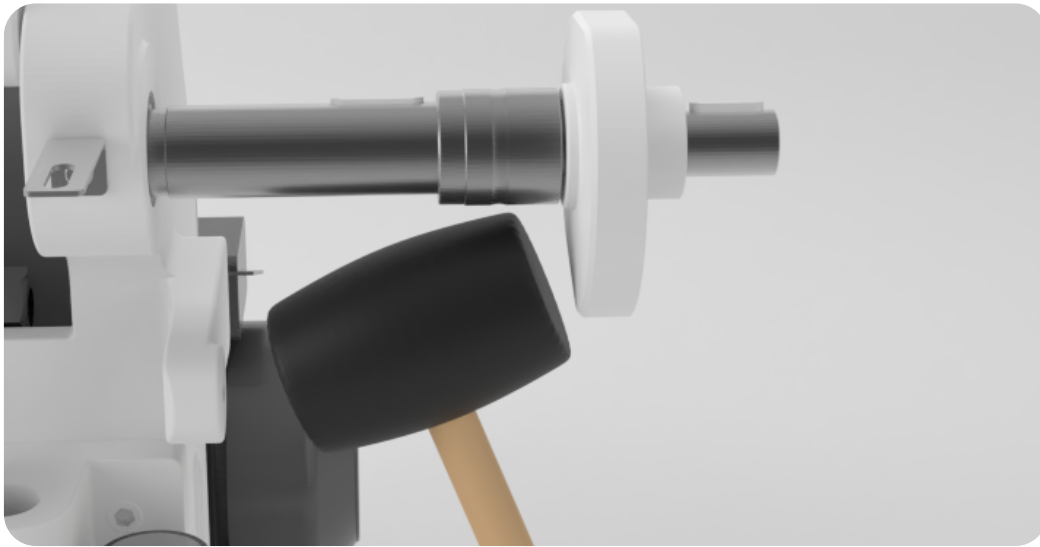

13. Keep tapping the Top Cam Drive Shaft until it goes completely through the TDP 5®'s Base.

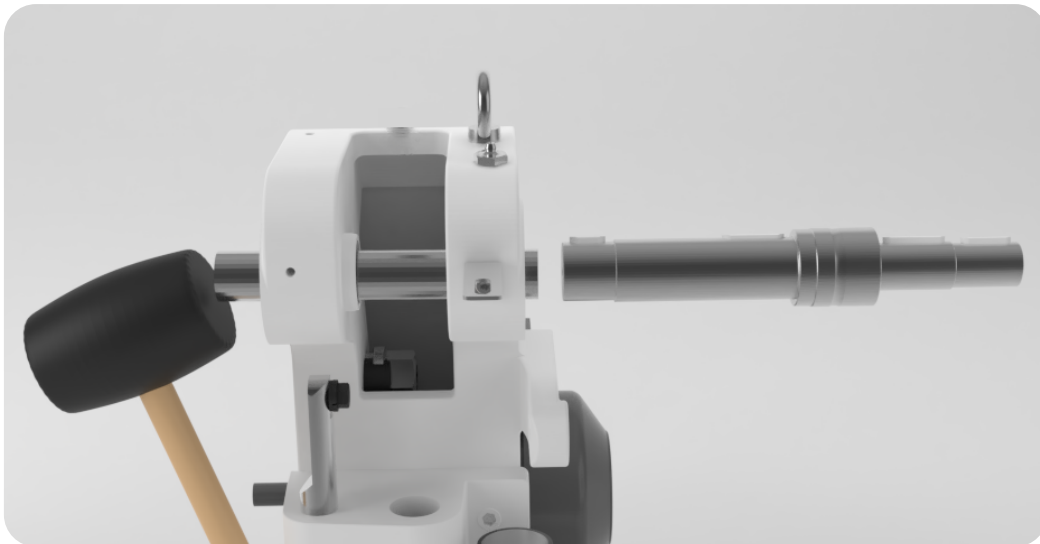

### Replace the Top Cam Drive Shaft

14. Gently begin to tap the new Top Cam Drive Shaft through the TDP 5<sup>®</sup> Base and the Eccentric Sheave and Eccentric Sheave Strap.

15. Continue to tap the Top Cam Drive Shaft until it is completely through the TDP 5<sup>®</sup> Base.



16. Insert the Boot Timing Cam onto the new Top Cam Drive Shaft's engraved key.



17. Reinsert the Upper Punch, Upper Drift Pin Assembly, and Upper Drift Pin Assembly Rod Eye and Clevis.

17.1 Note: Please refer to the repair Upper Drift Pin Assembly Rod Eye and Clevis instructions on page 51 for further assistance.

18. Reinsert the Cam Drive Cog, Pinion Gear, and Electrical Drive Flywheel.

18.1 Note: Please refer to the repair Cam Drive Cog instructions on page 83 for further assistance.

19. Reinsert the V Belt over the Electrical Drive Flywheel.

19.1 Note: Please refer to the repair V Belt instructions on page 69 for further assistance.

20. Reinsert the Boot and Boot Timing Bar.

20.1 Note: Please refer to the repair Boot Timing Bar instructions on page 39 and repair Boot instructions on page 42 for further assistance.

21. Insert the Hand Wheel on the new Top Cam Drive Shaft's engraved key.
22. Tighten the Hand Wheel Cap's bolt with an Allen key.

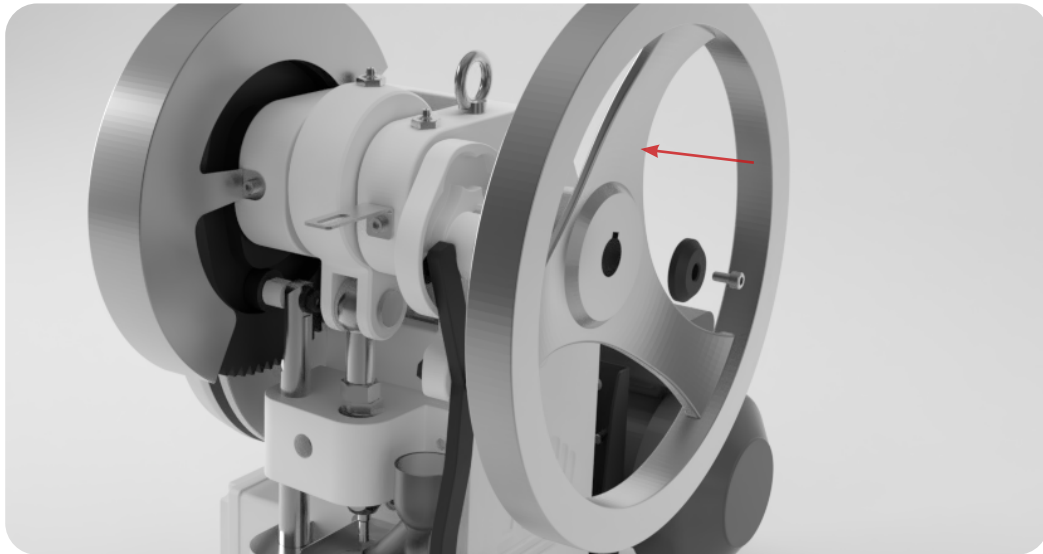

23. Reattach the Ejection Tray with an Allen key.

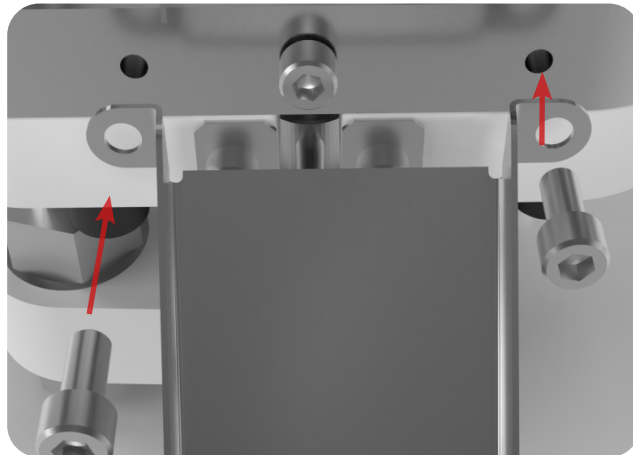

24. Reinsert the Hopper carefully and catch any powder still inside of it.

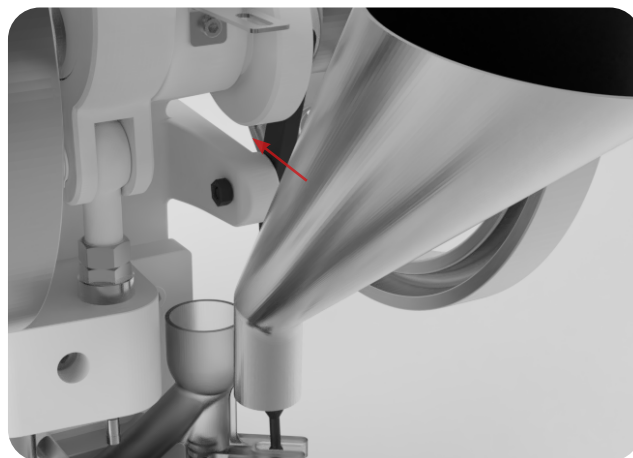

# Troubleshooting

Sometimes unavoidable issues will occur while operating the TDP 5<sup>®</sup>. Fortunately, there are several methods to remedy these issues.

## Common Machine/Part Issues

Symptom	Possible Cause	Possible Solution
<b>Machine freezes or locks up</b>	Grease point areas are dry.	Regularly oil and grease all the Grease Nipple points.
	There is excess pressure on the Upper Drift Pin Assembly.	Rotate the Upper Drift Pin Assembly counterclockwise.
	The V Belt is loose.	Adjust the Motor Support Arm's nuts to tighten the V Belt (correct tension is [N] 94.42).
	The press is being started with the Upper Punch at a low point.	Adjust the starting position so that the Upper Punch is at the highest point.
<b>Knocking sounds coming from machine</b>	The Upper Punch and Lower Punch are colliding with the Die.	After loosening its bolts, readjust the Base Plate until it is correctly aligned. After that, tighten the bolts back.
	The Upper Drift Pin Assembly is slightly off.	Loosen the Base Plate bolts and rotate the machine until the Upper Punch is aligned with the Die's bore. After that, tighten the bolts back.
	The V Belt is loose.	Adjust the Motor Support Arm's nuts to tighten the V Belt (correct tension is [N] 94.42).
	The teeth of the Pinion Gear and/or Cam Drive Cog are broken.	Replace the broken part.
	The Upper Drift Pin Assembly is not dropping smoothly in the powder filling stage of the process.	Check that there is not a buildup of powder between the Lower Punch and the Die. Then check that the Lower Drift Pin Assembly has enough clearance to drop through the hole in the Base.
<b>Heavy resistance during production</b>	The high friction areas are either unclean, locked, worn out, or not greased properly.	Apply grease to the Grease Nipple points and all high friction areas on the machine.

Symptom	Possible Cause	Possible Solution
<b>Inability to compact materials to tablet form</b>	Boot is blocked and not enough materials are flowing out.	Check the Boot for a potential clog.
	The Boot Timing Bar is not secured.	Tighten the Boot Timing Bar's nuts and bolt.
	There is not enough pressure.	Rotate the Upper Drift Pin Assembly clockwise.
	The Lower Punch is broken.	Remove the Lower Drift Pin Assembly to access the broken Lower Punch. After removing it, replace the Tooling.
	The Lower Drift Pin Assembly is not dropping properly during filling.	Check that there is not a buildup of powder between the Lower Punch and the Die. Then check that the Lower Drift Pin Assembly has enough clearance to drop through the hole in the base.
	There are flowing issues with the mix.	If the machine is able to make tablets with LFA's Firmapress <sup>®</sup> , then the problem is your mix. Adjust your formulation. If still an issue, contact LFA for support.
<b>Powder sticks to the Upper Punch</b>	There is damage to the Tooling or the Tooling's design is causing sticking.	Remove and replace the Tooling (Upper Punch, Lower Punch, and Die).
	There are issues with the mix.	Adjust your formulation. If still an issue, contact LFA for support.
<b>Powder sticks to the Lower Punch</b>	There are issues with the mix.	Adjust your formulation. If still an issue, contact LFA for support.



## Common Tablet Issues

Symptom	Possible Cause	Possible Solution
<b>Double tablets</b>	Previous tablet did not eject correctly.	Remove the double tablet manually from the Die bore.
	Excess granular materials were placed in the Die, which prevented the ejection of the existing tablet.	Clean the Tooling to remove any excess granular materials and make sure that it is clean and completely dry.
<b>Cracked or broken tablets</b>	There are problems with the formulation of the granules and ingredients.	If the machine is able to make tablets with LFA's Firmapress <sup>®</sup> , then the problem is your mix. Adjust your formulation. If still an issue, contact LFA for support.
	The Boot is not feeding enough material to be pressed in tablet form.	
	There is excess pressure.	Please read our article on Capping at <a href="https://www.lfatabletpresses.com/articles/tablet-capping">https://www.lfatabletpresses.com/articles/tablet-capping</a>
<b>Shattered tablets</b>	The Boot Timing Bar and the Boot are not adjusted properly.	Adjust the Boot Timing Bar by loosening/tightening its bolt and moving it.
	Air is becoming trapped in the tablet during compression.	Please read our article on Capping at <a href="https://www.lfatabletpresses.com/articles/tablet-capping">https://www.lfatabletpresses.com/articles/tablet-capping</a>
	The ejection height is incorrect.	Rotate the Upper Cog in the Lower Drift Pin Assembly by hand until the ejection height is at the correct level.
<b>Inconsistent Tablet Weight</b>	The Lower Drift Pin Assembly Locking Bar is loose.	Check that the Lower Drift Pin Assembly Locking Bar is secured to the Lower Drift Pin Assembly and the Lower Drift Pin Assembly Cogs.
	Not enough pressure is being exerted.	Rotate the Upper Drift Pin Assembly clockwise.
	There are flowing issues with the mix.	If the machine is able to make tablets with LFA's Firmapress <sup>®</sup> , then the problem is your mix. Adjust your formulation. If still an issue, contact LFA for support.
<b>Soft tablets</b>	There is too little punch pressure.	Rotate the Upper Drift Pin Assembly clockwise.
	There are flowing issues with the mix.	If the machine is able to make tablets with LFA's Firmapress <sup>®</sup> , then the problem is your mix. Adjust your formulation. If still an issue, contact LFA for support.
<b>Uneven tablets</b>	The Tooling is worn out.	Check the ingredients of your formula before you replace the Die, Upper Punch, and Lower Punch.

# De-Jamming the TDP 5<sup>®</sup>

There are several reasons why a TDP 5<sup>®</sup> might jam such as:

- The fill depth is set too low and the pressure is set too high.
- There is a build up of powder sticking to the Tooling.
- Any powder buildup on the machine can cause tablets to eject backwards and not forwards, creating potential for a double tablet becoming stuck in the Die's bore.



**WARNING:** To prevent any potential personal injury, ALWAYS unplug the TDP 5<sup>®</sup> before de-jamming it.

## Tools and Materials Needed

- Set of metric Allen keys with ball ends
- De-Jamming Bar
- Hammer (if Die is difficult to remove)
- Cleaning brush
- 13 mm wrench
- Disposable latex/rubber gloves (for food grade products and to protect hands from grease)
- Hairnet and/or beard net (food grade products only)
- Sterile shoe covers (food grade products only)

## Instructions

Note: Wear latex/rubber gloves (and appropriate food grade attire if applicable) during this process.

### Method 1: Use the De-Jamming Bar

Note: Please refer to the Dismantling for Repair and Replacement section for additional assistance.

1. Remove the Hopper carefully and catch any powder that is inside of it.

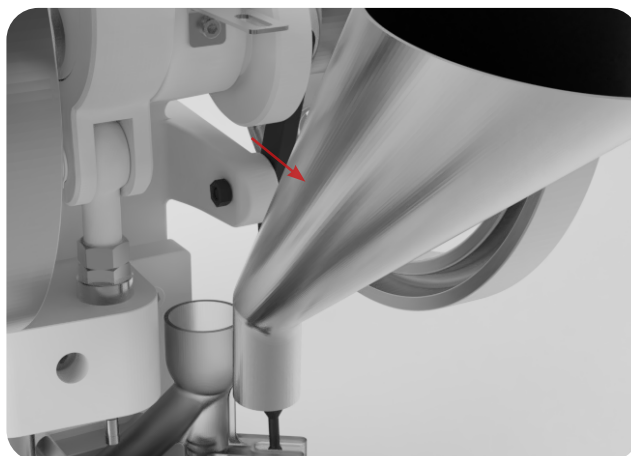

2. Loosen the Boot's set screw with an Allen key.
3. Remove the Boot Bolt and Spring underneath the Boot with an Allen key.

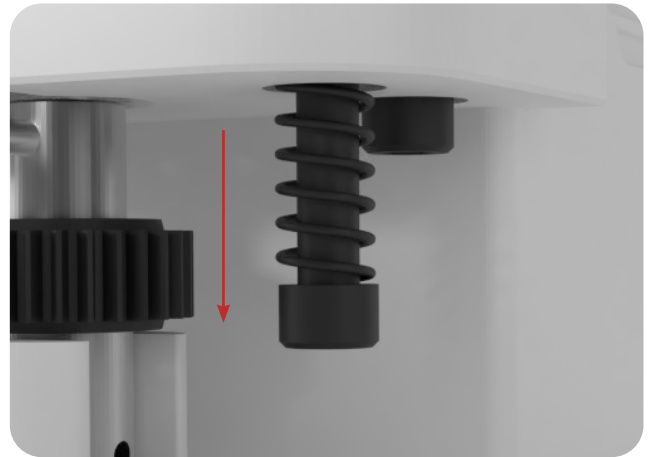
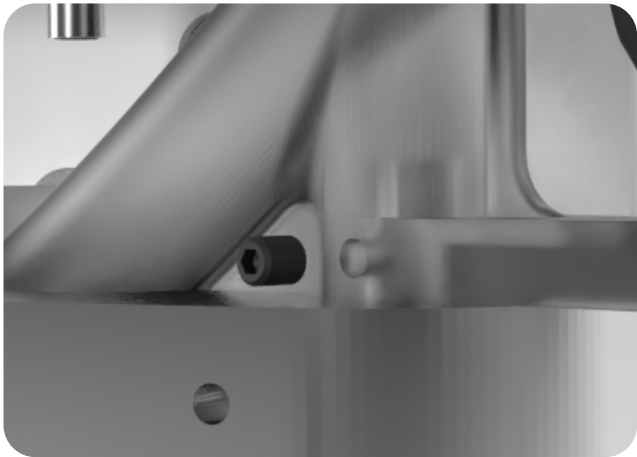

4. Take off the Boot carefully and remove any powder that is inside of it.

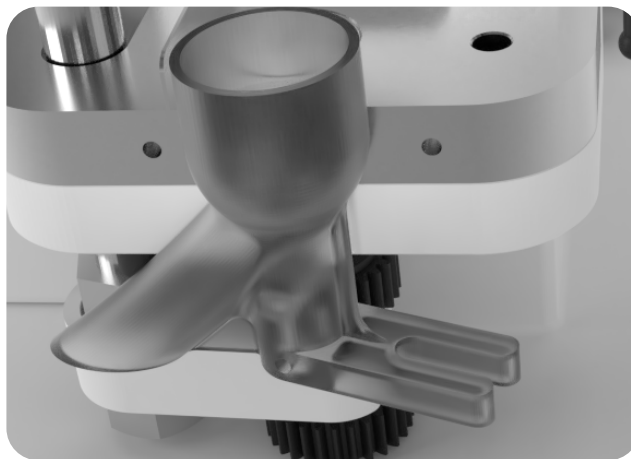

5. Insert the De-Jamming Bar into one of the holes on the Electrical Drive Flywheel.
6. Pull down the De-Jamming Bar until the Electrical Drive Flywheel gives way.

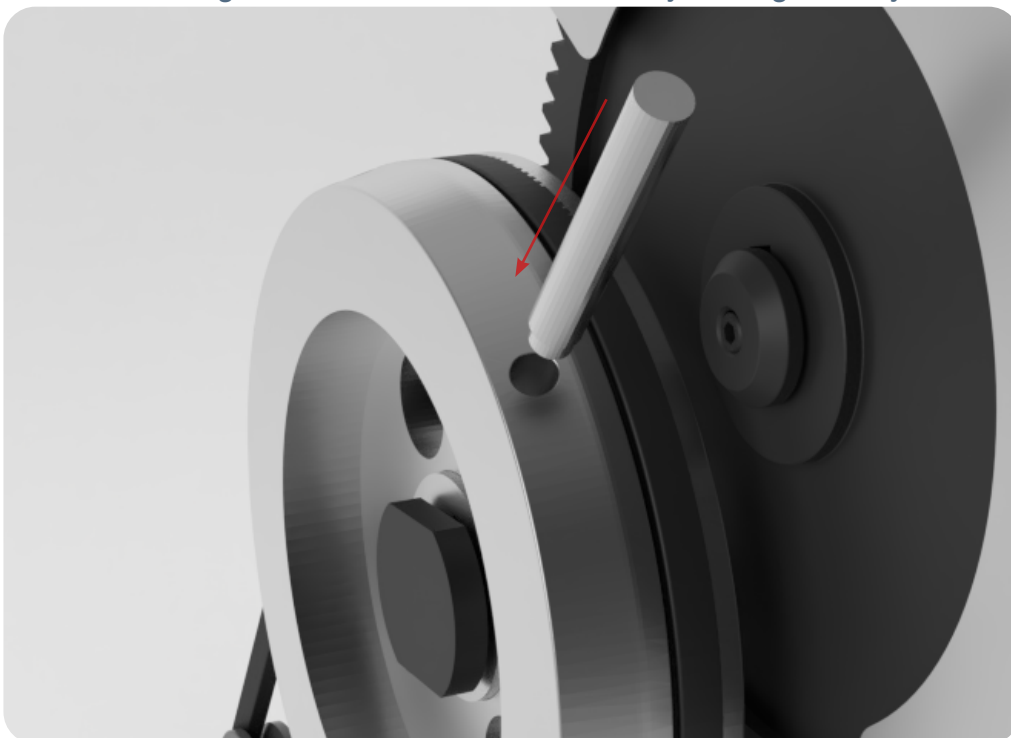

7. Reposition the Boot on the Base Plate correctly and insert the Boot Timing Bar's end in the boot.

8. Resecure the Boot Bolt and Spring underneath the Boot with an Allen key.

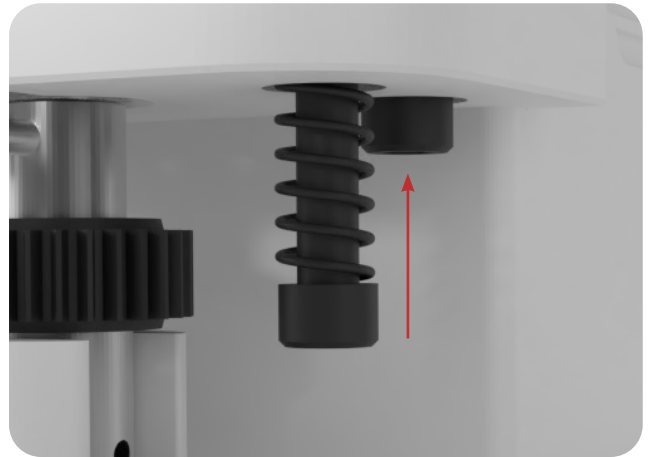
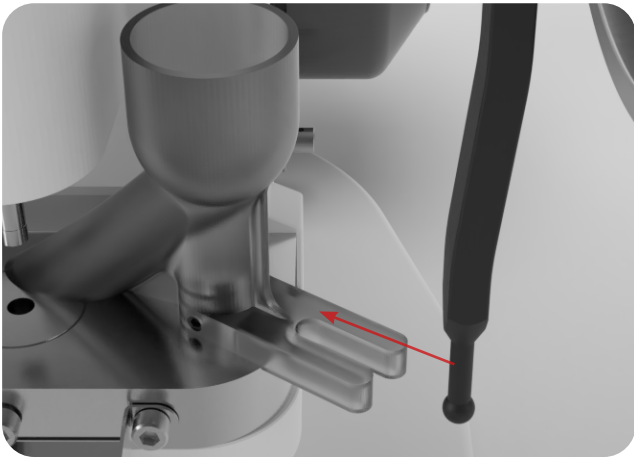

9. Tighten the Boot's set screw with an Allen key.

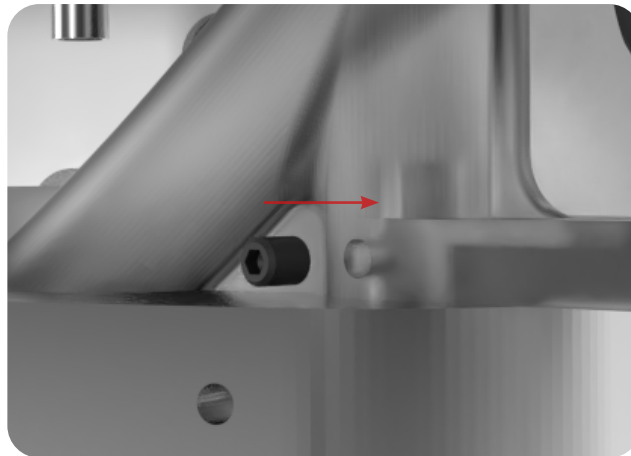

10. Turn the Hand Wheel for one rotation of the Top Cam Drive Shaft to ensure that the machine runs smoothly before plugging it in and turning it on.

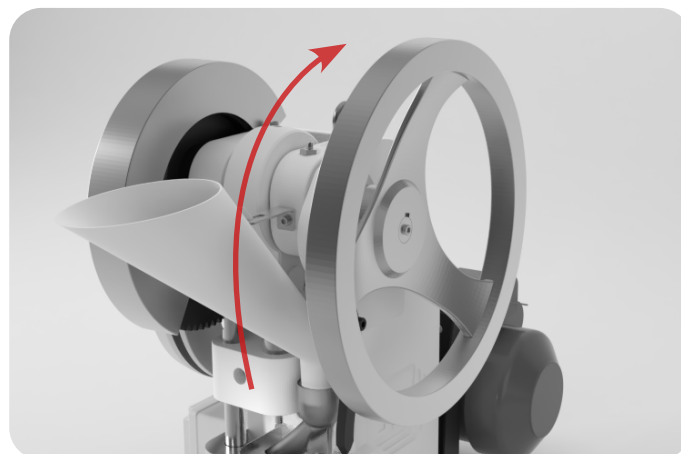

## Method 2: Run a Reverse Rotation

Note: Please refer to the Dismantling for Repair and Replacement section for additional assistance.

1. Remove the Hopper carefully and catch any powder that is inside of it.
2. Loosen the Boot's set screw with an Allen key.

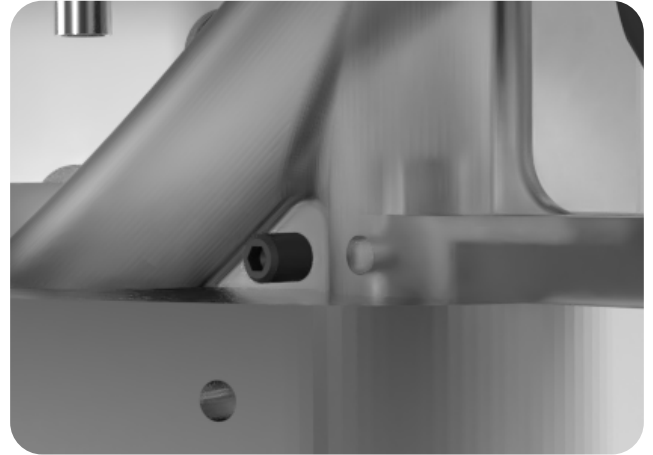
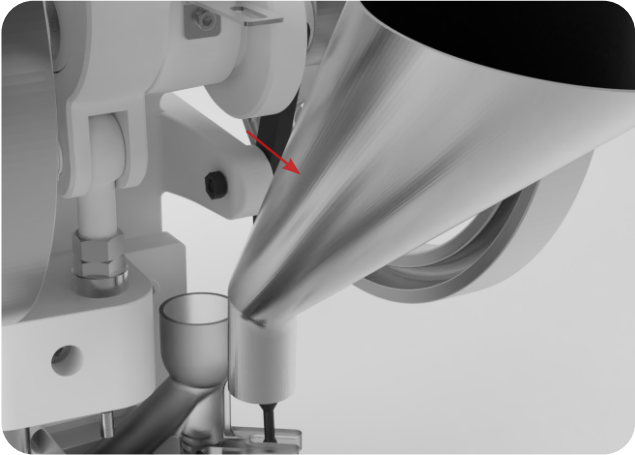

3. Remove the Boot Bolt and Spring underneath the Boot with an Allen key.
4. Take off the Boot carefully and remove any powder that is inside of it.

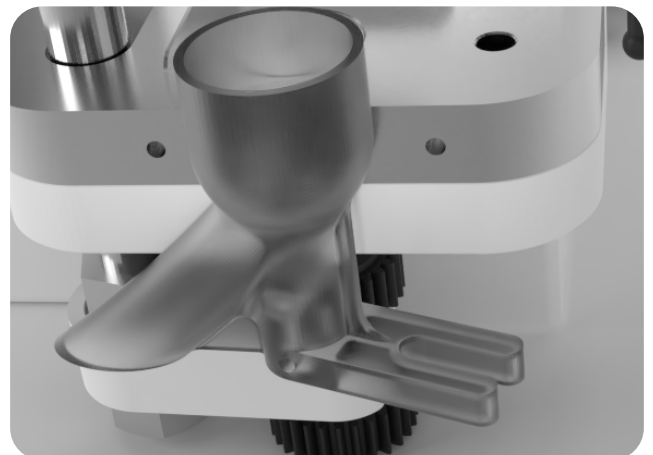
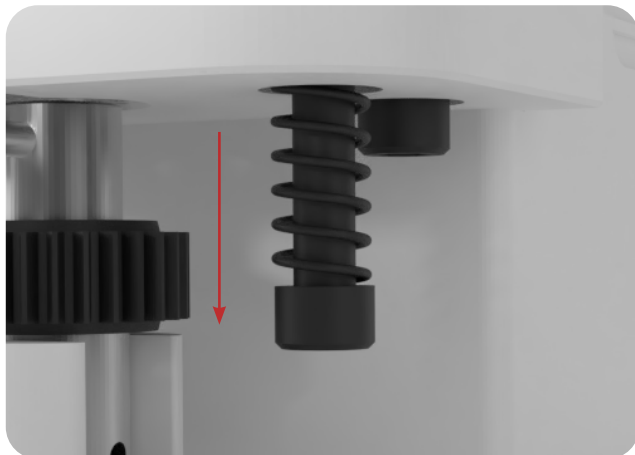

5. Turn the Hand Wheel in the reverse direction for a few rotations.

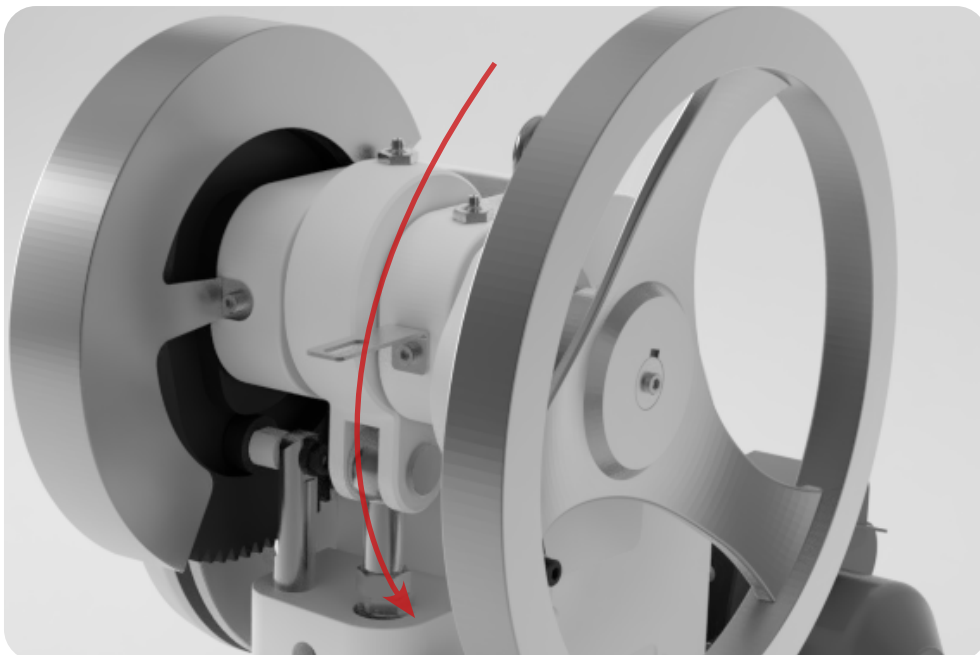

6. Reposition the Boot on the Base Plate correctly and insert the Boot Timing Bar's end in the boot.

7. Resecure the Boot Bolt and Spring underneath the Boot with an Allen key.

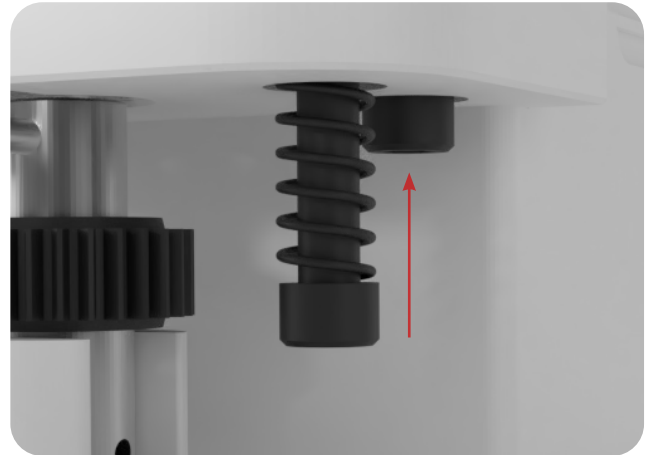
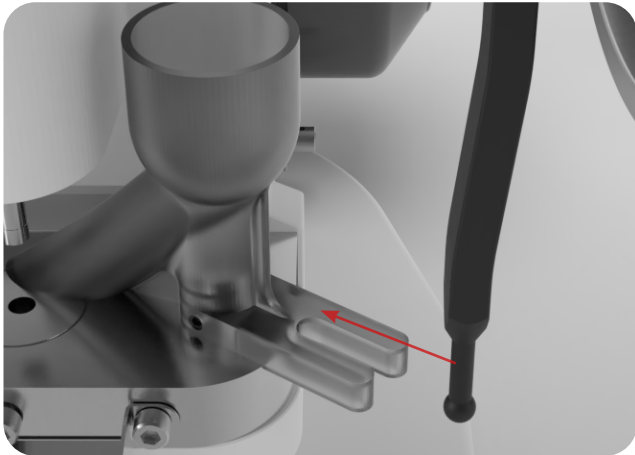

8. Tighten the Boot's set screw with an Allen key.

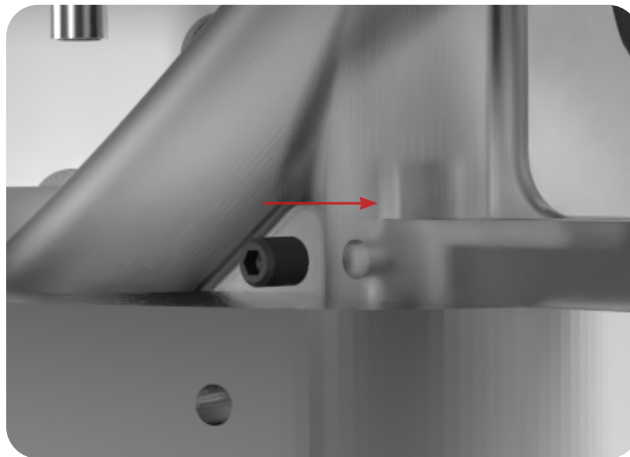

9. Turn the Hand Wheel for one rotation of the Top Cam Drive Shaft to ensure that the machine runs smoothly before plugging it in and turning it on.

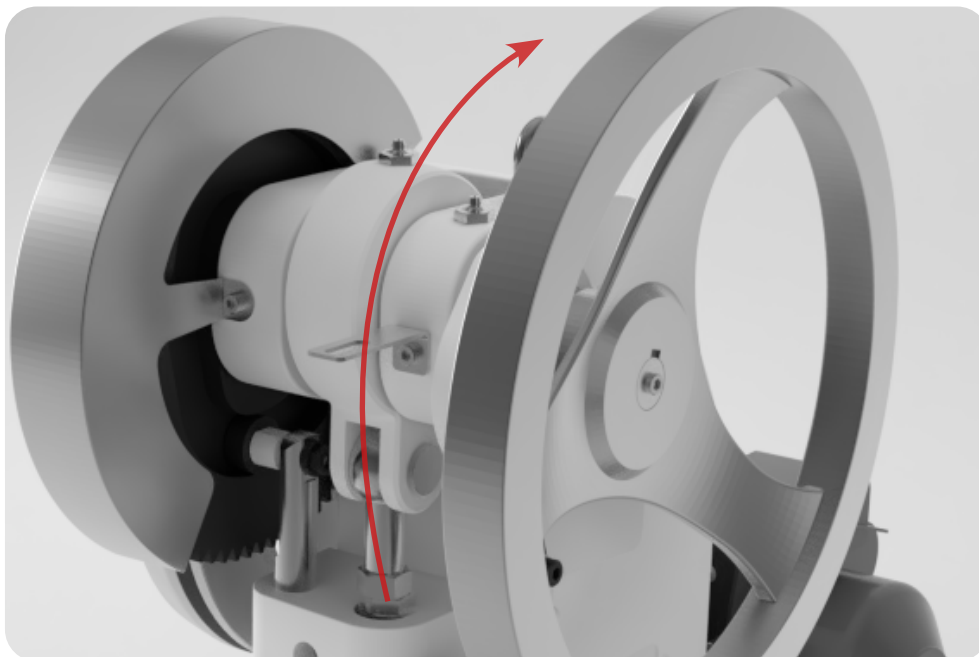

# Cleaning

During the TDP 5<sup>®</sup>'s operation, excess powder will find its way into parts of the machine, particularly in the Base, Hopper, Boot, Base Plate, and Tooling. It is important to clean the TDP 5 thoroughly to prevent rusting and cross contamination. To watch a video of a TDP 5<sup>®</sup> cleaning, go to <https://www.lfatabletpresses.com/videos/cleaning-your-tdp-5-tablet-press>

LFA recommends that the machine be cleaned after each operation.

## Tools and Materials Needed

- Cleaning brush
- Long wire pipe cleaner
- Toothbrush
- Cleaner (such as heavy duty foam cleaner; NSF approved if food grade product)
- Set of metric Allen keys with ball ends
- 13 mm wrench
- 24 mm wrenches (2)
- Grippers or pliers (if parts are difficult to remove)
- Hammer (if Die is difficult to remove)
- Disposable latex/rubber gloves
- Bagless vacuum
- 3 clean cloths
- Potable water
- Bowl of warm soapy water (nothing abrasive)
- Sanitizer (e.g. Member's Mark Commercial Sanitizer)
- Hairnet and/or beard net (food grade products only)
- Safety goggles
- Sterile shoe covers (food grade products only)



**WARNING:** To prevent any potential personal injury, ALWAYS unplug the TDP 5<sup>®</sup> from the electrical outlet when replacing parts.

## Instructions

Note: Wear safety goggles and latex/rubber gloves (and appropriate food grade attire if applicable) during this process.

### Remove Parts

1. Remove the Hopper carefully and catch any powder still inside it.
2. Remove excess powder and any tablets from the Ejection Tray with a cleaning brush.
3. Remove the Ejection Tray with an Allen key.

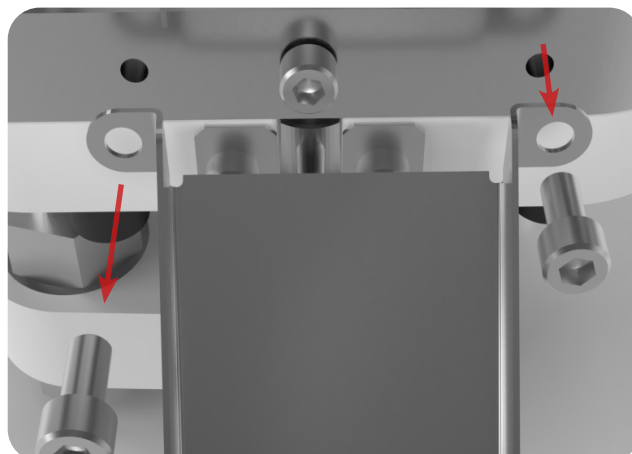



4. Loosen the Boot's set screw with an Allen key.

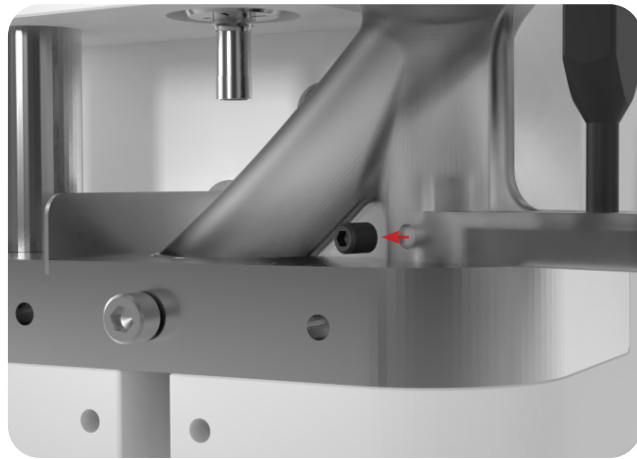

5. Remove the Boot Bolt and Spring underneath the Boot with an Allen key.

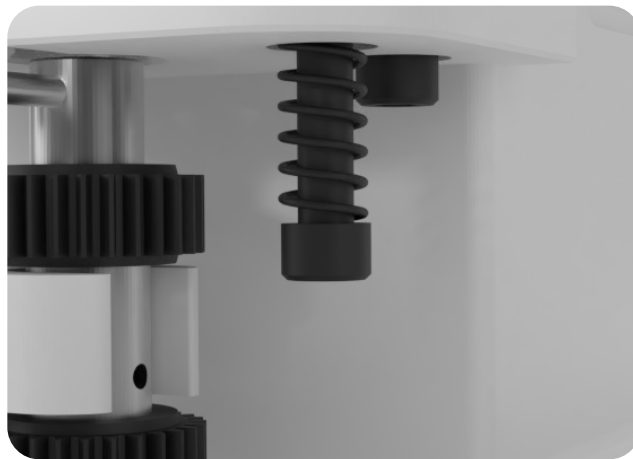

6. Take off the Boot carefully and remove any powder still inside it.

7. Loosen the bolts underneath the Base Plate with an Allen key.

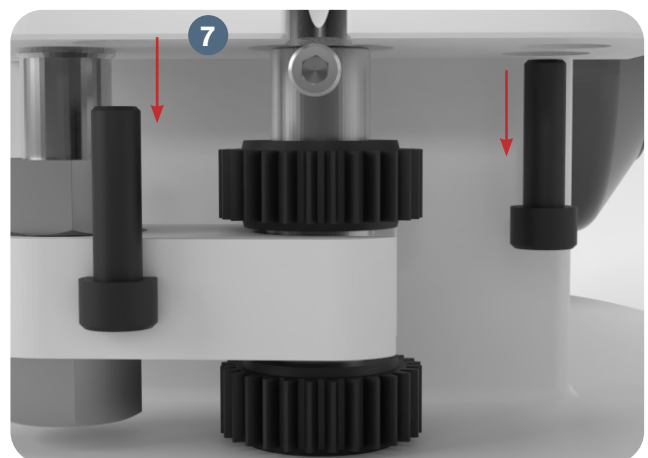
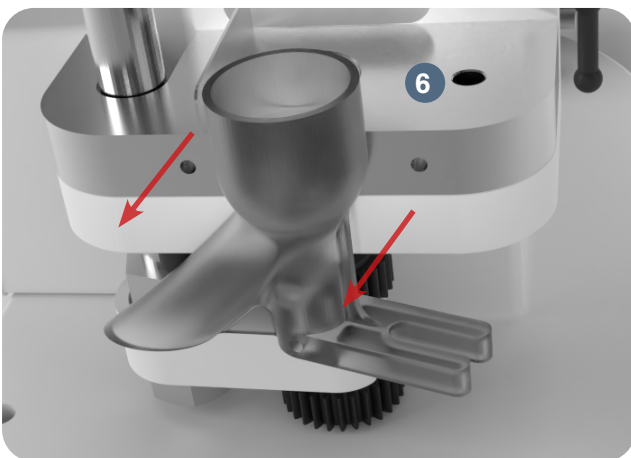



8. Turn the Hand Wheel until the Upper Drift Pin Assembly is lowered.
9. Loosen the Upper Punch Die Locking Nut with a wrench while keeping the Upper Punch Drift Assembly in place with another wrench.
10. Remove the Upper Punch by hand.

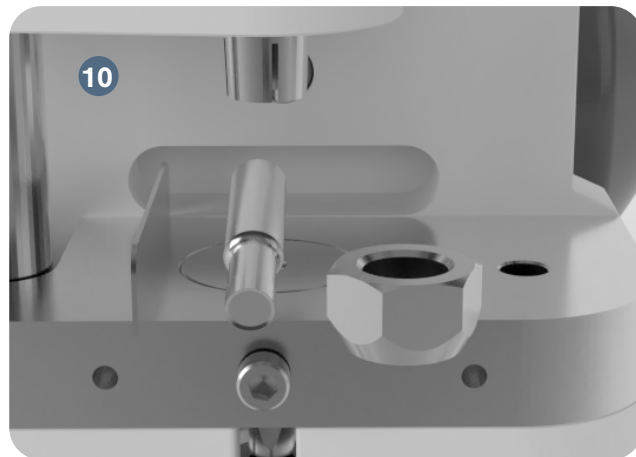
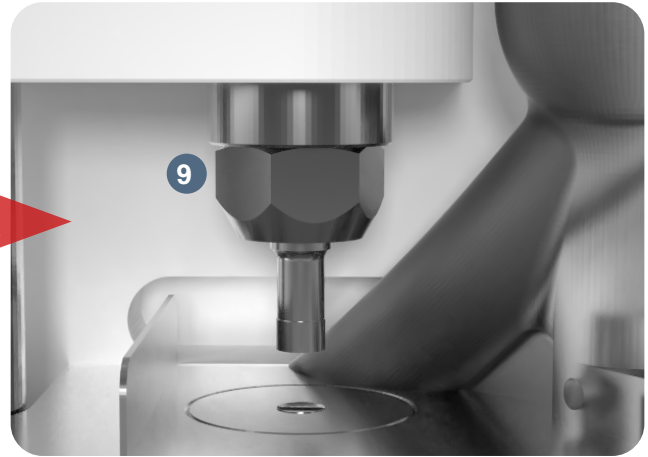
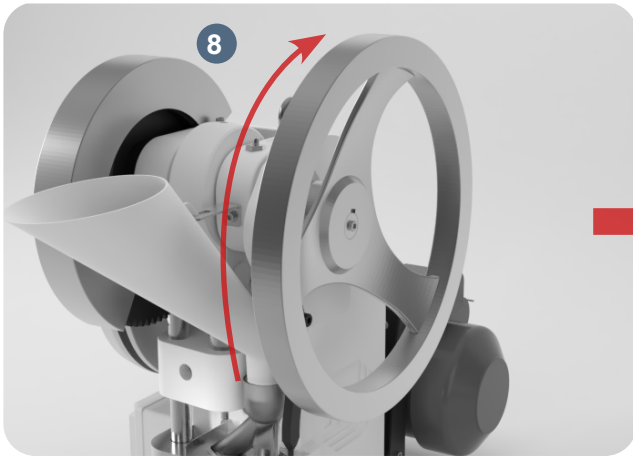

10.1 Note: If you cannot remove by hand, carefully use grippers or pliers.

11. Remove the Base Plate with the Die still inside it.
12. Remove the bolt that locks the Die with an Allen key.
13. Take out the Die from the middle of the Base Plate.  
13.1 Note: Lightly tap the Die with a hammer if it is difficult to remove.

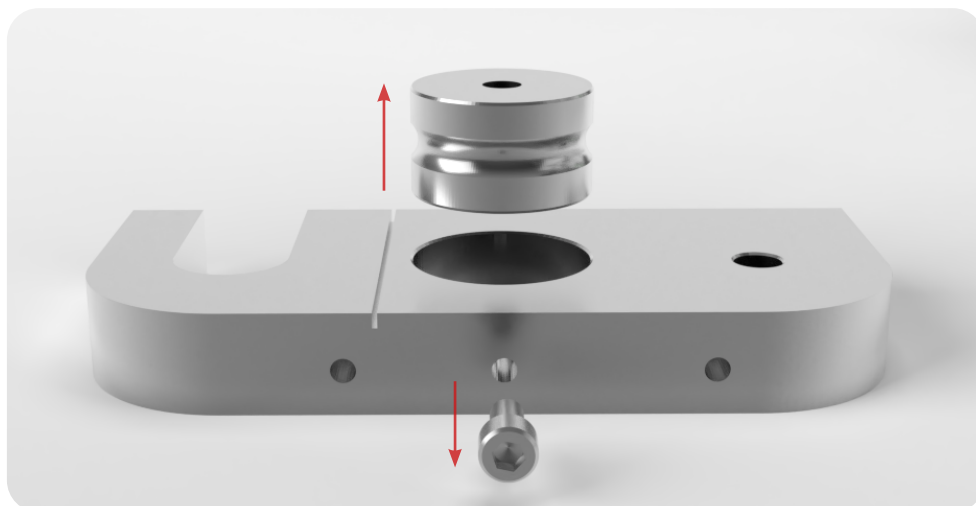

14. Remove the bolt that locks the Lower Punch with an Allen key.
15. Remove the Lower Punch by hand.

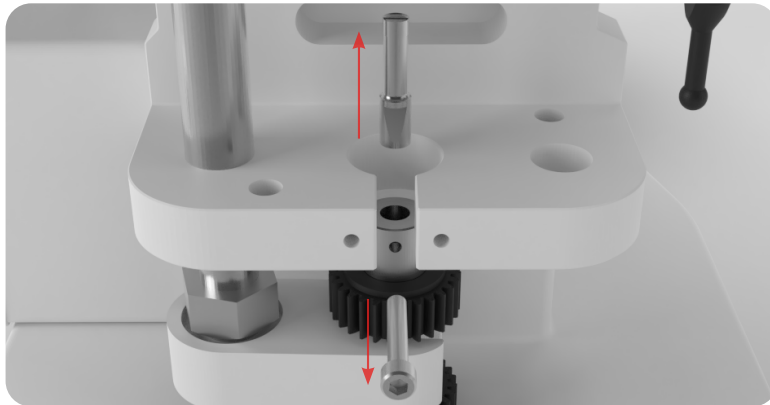

15.1 Note: If you cannot remove by hand, carefully use grippers or pliers.

#### Clean the Base

16. Vacuum any powder/debris from the machine.
17. Spray the TDP 5<sup>®</sup> Base with the cleaner, particularly in the Tooling's location.
18. Rinse the cleaner off with potable water.
19. Sanitize the TDP 5<sup>®</sup> Base with a clean cloth.

Note: Before washing the Base Plate, LFA recommends using our Die Seat Cleaner. You can order the Die Seat Cleaner and Insertion Ring on our website at <https://www.lfatabletpresses.com/die-seat-cleaner-insertion-ring>

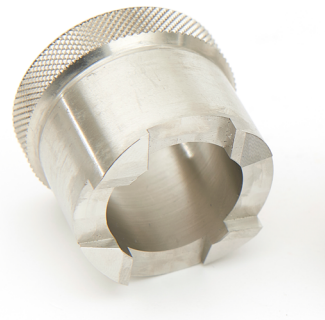

#### Clean the Parts

20. Take one of the parts removed from the machine and submerge it in the bowl of warm soapy water.
  - 20.1 Note: To ensure that all dirt and debris are removed, wash one part at a time.
21. Take a clean cloth and carefully wash the part thoroughly.
  - 21.1 Note: Use the toothbrush for difficult-to-remove debris. When cleaning tooling, use non-abrasive cleaning equipment such as a soft pipe cleaner and soft cloth.
22. Dry part immediately after it is cleaned and rinsed.
23. Sanitize part with a clean cloth.
24. Repeat steps 20-23 for each remaining part until they are all clean.

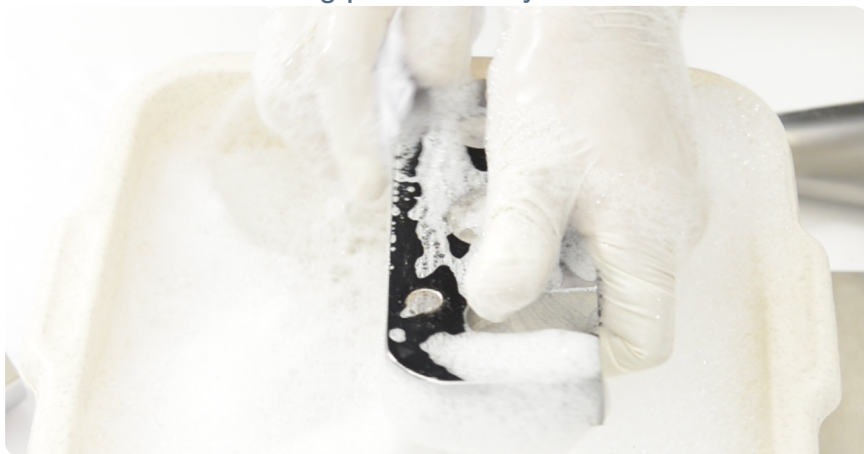

## Cleaning Schedule Matrix

Part	Frequency							
	After installing machine	After every use	Before every use	In between products that present a cross contamination risk	Weekly	Monthly	Before placing in storage	After removing from storage
Ejection Tray	Remove from machine	Remove from machine	Install on machine	Remove from machine	N/A	N/A	Remove from machine	Install on machine
Tooling	Remove from machine	Remove from machine	Install into machine	Remove from machine	N/A	N/A	Remove from machine	Install on machine
Boot	Remove from machine	Remove from machine	Install into machine	Remove from machine	N/A	N/A	Remove from machine	Install on machine
Base Plate	Remove from machine	Remove from machine	Install on machine	Remove from machine	N/A	N/A	Remove from machine	Install on machine
Hopper	Remove from machine	Remove from machine	Install on machine	Remove from machine	N/A	N/A	Remove from machine	Install on machine
Top Cam area	Clean in machine	Clean in machine	Clean in machine	Clean in machine	Clean in machine	Clean in machine	Clean in machine	Clean in machine
Cam Drive Cog	Clean in machine	Clean in machine	Clean in machine	Clean in machine	Clean in machine	Clean in machine	Clean in machine	Clean in machine
Upper Drift Pin Assembly	Remove from machine	Remove from machine	Remove from machine	Remove from machine	Remove from machine	Remove from machine	Remove from machine	Remove from machine
Motor	Clean on machine	Clean in machine	Clean in machine	N/A	Clean on machine	Clean in machine	Clean on machine	Clean on machine
Upper Drift Pin Assembly Mounting Block	Clean in machine	Clean in machine	Clean in machine	Clean in machine	Clean in machine	Clean in machine	Clean in machine	Clean in machine
Upper Drift Pin Assembly Threaded Cam	Clean in machine	Clean in machine	Clean in machine	Clean in machine	Clean in machine	Clean in machine	Clean in machine	Clean in machine
Lower Drift Pin Assembly	Remove from machine	Remove from machine	Remove from machine	Remove from machine	Remove from machine	Remove from machine	Remove from machine	Remove from machine
Electrical Drive Flywheel	Clean on machine	Clean in machine	Clean in machine	Clean in machine	N/A	Clean on machine	Clean on machine	Clean on machine
Base/Frame	Clean on machine	Clean in machine	Remove from machine	Remove from machine	N/A	N/A	Clean in machine	Clean on machine

Cleaning Level Key	
Level 1 - Remove powder	
Level 2 - Dry clean with cloth	
Level 3 - Dry clean and re-lubricate if specified in lubrication schedule	
Level 4 - Wet clean and re-lubricate if specified in lubrication schedule	
<b>Remove from machine - Take part out of machine and clean if required. Store it correctly or install back into machine.</b>	
<b>Install into machine - Install part into the machine and make sure that it has been cleaned. If needed, lubricate to the level required.</b>	
<b>Clean on/in machine - Clean the part while in the machine and do not remove it. Make sure that all contact surfaces are clean to the level required.</b>	

This cleaning matrix is intended as a guide only and is not an exhaustive list. All cleaning schedules will need to be adapted to the industry and product, following industry regulations and the material safety data sheets that come with specific products. Please check with your Food Safety Manager/Department, Quality Control Manager/Department, or other relevant internal departments at your company before using.

## Storing the TDP 5<sup>®</sup>

After its thorough cleaning, the TDP 5<sup>®</sup> needs to be stored in the proper conditions. It is important to store it in an environment in which the machine is safe from rusting. The TDP 5<sup>®</sup>'s high traction areas and the Tooling need to be lubricated separately before you store them.

### Tools and Materials Needed

- Plastic wrapping to cover machine
- Airtight container for Tooling (if in storage for more than a week)
- Grease gun
- Lubricant/grease (food grade lubricant if machine has a high chance of contact with the food or drug product)
- Disposable latex/rubber gloves (for food grade products and to protect hands from lubricant)
- Hairnet and/or beard net (food grade products only)
- Sterile shoe covers (food grade products only)

### Instructions

Note: Wear latex/rubber gloves (and appropriate food grade attire if applicable) during this process.

### Lubricating the Tooling

If you are not using the machine for more than a week, store the Tooling in an airtight container and cover it with lubricant to prevent rust formation. If not, simply lubricate each part of the Tooling and reinsert it back into the machine.

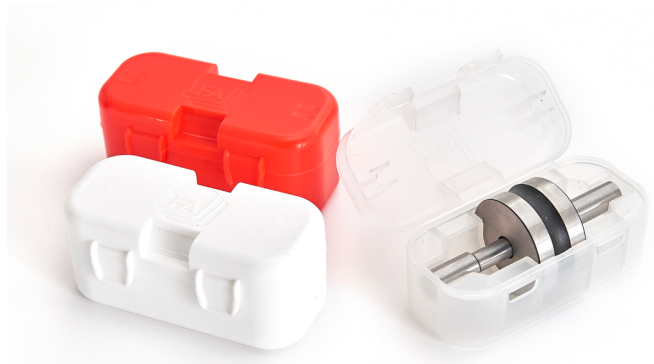

LFA's TDP<sup>®</sup> Tooling Case provides airtight storage and is perfect for transport and protection. Order at <https://www.lfatabletpresses.com/tooling-case-tdp>

1. Rub a finger's worth of grease on the Boot Timing Cam's side.
  - 1.1 Note: Be sure to grease around the Boot Timing Cam Runner.
2. Lubricate the Grease Nipple on top of the Eccentric Sheave Strap with the grease gun.
  - 2.1 Note: Rotate the Hand Wheel during this to ensure grease gets in between the Eccentric Sheave and the Eccentric Sheave Strap.
3. Lubricate the Grease Nipple nearest to the Boot Timing Cam.
  - 3.1 Note: Rotate the Hand Wheel during this to ensure grease gets in between the TDP 5<sup>®</sup> Base and Top Cam Drive Shaft.

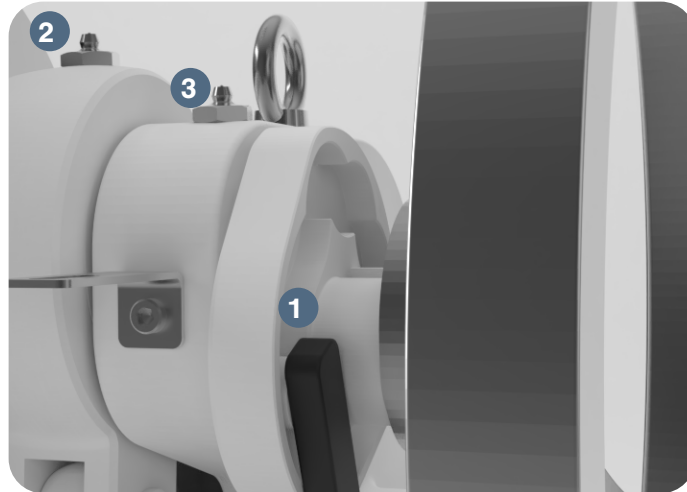

4. Lubricate the Cam Drive Cog and Lower Drift Pin Assembly Timing Rod Runner Bolt.
5. Lubricate the Pinion Gear.

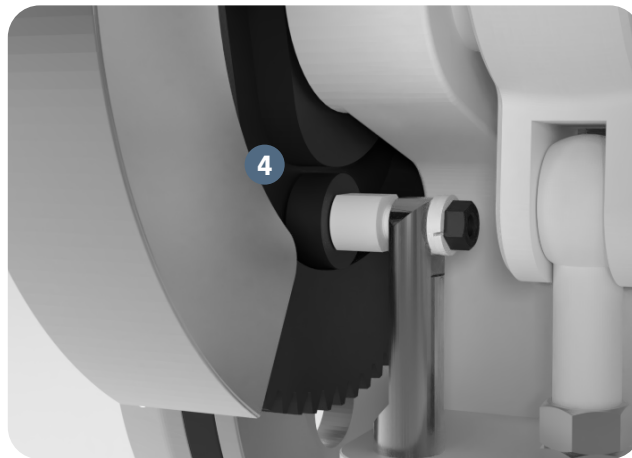

You can also lubricate any point of traction on the TDP 5<sup>®</sup> at your own discretion; just be sure not to over-lubricate.

**Cover the TDP 5<sup>®</sup>**

6. Carefully cover the TDP 5<sup>®</sup> with the plastic wrapping.
  - 6.1 Note: You can use the plastic wrapping that came with the machine in the shipping container.

**Environmental Conditions**

It is important that the environment in which you store the TDP 5<sup>®</sup> has the appropriate temperature and relative humidity levels. These two environmental factors can potentially cause the machine to rust and/or cause the tablets to have a lower quality. The table below shows the acceptable temperature and relative humidity levels:

Machine	Temperature		Humidity
TDP 5	°C	°F	45-65% RH
	18-24	64-75	

# Appendix

## Glossary

Term	Definition
API/Active Pharmaceutical Ingredient	Any substance or mixture of substances used that is an active ingredient in the drug product.
Binding agent	See excipient.
Die	The part of the Tooling that makes up the hole in which the powder is compressed and shaped into a tablet.
Die bore	The cavity inside the middle of the Die.
Die face	The very top flat surface of the Die.
Ejection height	The height at which the Lower Punch is lifted to for a tablet's ejection from the machine.
Excipient	An inactive substance that serves as the vehicle or medium for a drug or other API.
Fill depth	The amount of space that the powder can flow into in the Die.
Formulation	Powder mix of the excipient and the API that is compressed to make tablets.
Granular material	See Formulation.
Kilonewton (kN)	The force to accelerate a mass of 1 kg at a constant 1 m per second.  The TDP® range's pressure is measured in this unit.
Punches	The Upper Punch and Lower Punch have concave endings in the shape of the desired tablet. When the punches meet, they compress the powder between.
Punch pressure	The adjustable amount of force that is used to press tablets.
TDP®	LFA trademarked term for desktop tablet press.
Tooling	Enables a tablet press to form tablets. It consists of a Die, Upper Punch, and Lower Punch.

## Description of TDP 5<sup>®</sup> Parts

### **TDP Base (#AEC0000)**

The TDP Base is the main base for the TDP 5<sup>®</sup>, and all working parts are connected to it. It is important that the TDP Base be fixed onto a stable and secure workbench.

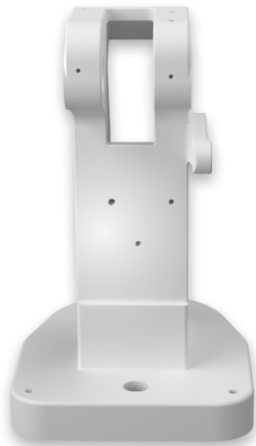

### **Tooling**

The Tooling consists of the Die, the Upper Punch, and the Lower Punch. This die set compresses the powder into the tablet. Order at <https://www.lfatabletpresses.com/tdp-tooling>

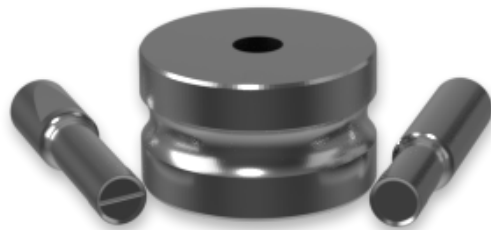

### **Lower Drift Pin Assembly Locking Bar**

#### **(#AEC0013)**

The Lower Drift Pin Assembly Locking Bar holds the Lower Drift Pin Assembly Cogs in place.

Order at <https://www.lfatabletpresses.com/tdp5-lower-pin-locking-bar>



### **Lower Drift Pin Assembly Cogs (#AEC0012)**

The Lower Drift Pin Assembly Cogs are used to adjust the tablet's fill depth and ejection height. They are located in the Lower Drift Pin Assembly. The Upper Cog adjusts the ejection height of the tablet. Turning it counterclockwise raises the ejection height, and turning it clockwise lowers it. The Lower Cog increases the tablet's fill depth (weight). Turning it clockwise increases the weight of the tablet, and turning it counterclockwise decreases the weight. Order at <https://www.lfatabletpresses.com/tdp5-lower-pin-cogs>

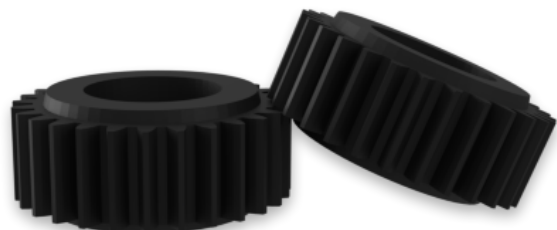



### **Boot (#AEC0036)**

The Boot is where the dry granular materials are held for pressing. It fills the Die bore with the dry granular material and moves the finished tablet out of the Die before refilling it with the next batch of materials. Order at <https://www.lfatabletpresses.com/tdp5-boot>



### **Boot Bolt and Spring (#AEC0051; #AEC0055)**

The Boot Bolt and Spring holds the Boot in place while the press is running and allows it to move back and forth. It is kept secure with the set screw on the side of the Boot. Order at <https://www.lfatabletpresses.com/tdp5-boot-bolt-spring>



### **Electrical Drive Flywheel (#AEC0021)**

The Electrical Drive Flywheel is attached to the Motor via the V Belt. Order at <https://www.lfatabletpresses.com/tdp5-drive-wheel>

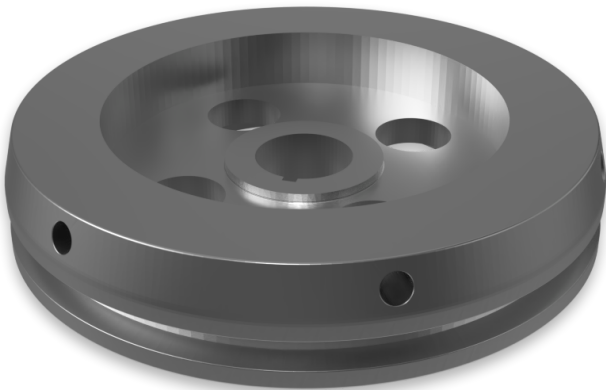

### **Upper Drift Pin Assembly (#AEC0002)**

The Upper Drift Pin Assembly holds the Upper Punch in place while being able to adjust the punch pressure. It is attached to the Eccentric Sheave. Order at <https://www.lfatabletpresses.com/tdp5-upper-drift-pin-assembly>



### **Hopper (#AEC0030)**

The Hopper is the funnel that holds the granular materials before it moves into the Boot to be pressed. Order at <https://www.lfatabletpresses.com/tdp5-hopper>

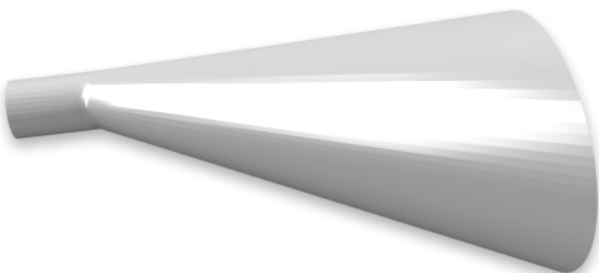

### **Eccentric Sheave Strap (#AEC0004)**

The Eccentric Sheave Strap attaches the Upper Drift Pin Assembly to the Top Cam Drive Shaft. Order at <https://www.lfatabletpresses.com/tdp5-eccentric-sheave-strap>

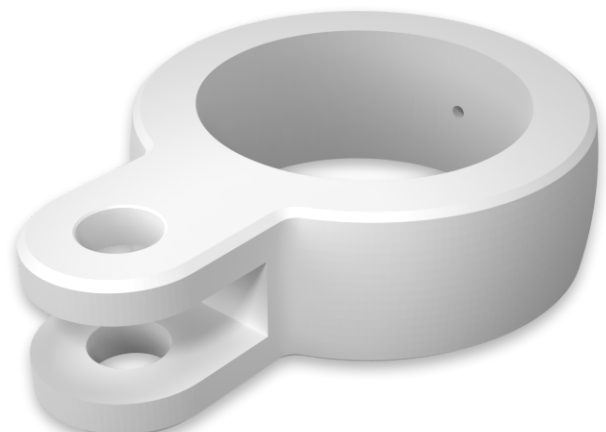



**Upper Drift Pin Assembly Rod Eye and Clevis (#AEC0005)**

The Upper Drift Pin Assembly Rod Eye and Clevis is the part that connects the Eccentric Sheave to the Upper Drift Pin Assembly, which holds the Upper Punch. Order at <https://www.lfatabletpresses.com/tdp5-upper-drift-assembly-cam>

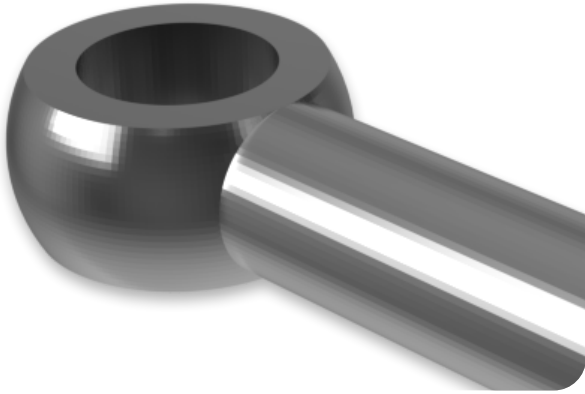

**Boot Timing Cam (#AEC0038)**

The Boot Timing Cam is responsible for the movement of the Boot Timing Bar, which allows the Boot to fill the Die bore with the dry granular materials needed to form the tablet. Order at <https://www.lfatabletpresses.com/tdp5-boot-timing-cam>

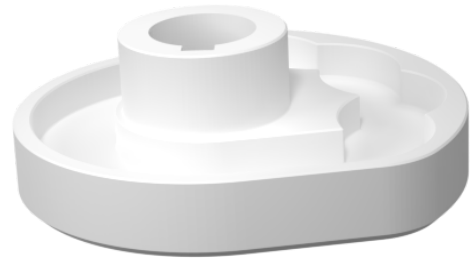

**Top Cam Drive Shaft (#AEC0037)**

All other TDP 5<sup>®</sup> parts are connected to the Top Cam Drive Shaft. As it is turned, all the parts of TDP 5<sup>®</sup> move. Order at <https://www.lfatabletpresses.com/tdp5-top-cam>

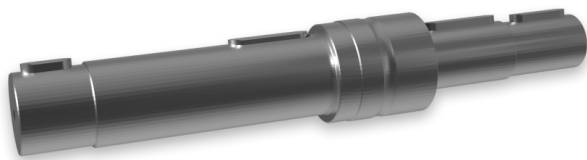

**Eccentric Sheave (#AEC0033)**

The Eccentric Sheave controls the timing of the Upper Drift Pin Assembly. Order at <https://www.lfatabletpresses.com/tdp5-eccentric-sheave>

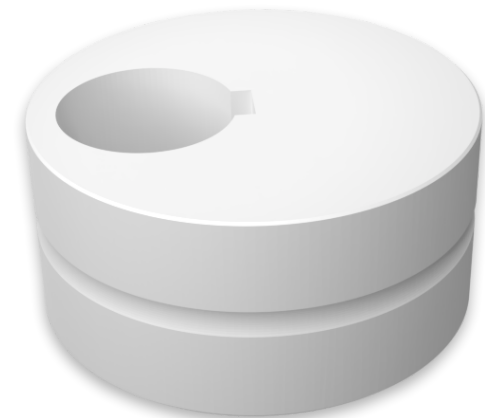

**Grease Nipple**

Grease Nipples are grease cap points that grease the TDP 5<sup>®</sup>'s gaps with high pressure. Order at <https://www.lfatabletpresses.com/tdp5-grease-nipple>



**Lower Drift Pin Assembly Timing Rod (#AEC0014)**

The Lower Assembly Timing Rod raises the finished tablet out of the Die. Order at <https://www.lfatabletpresses.com/tdp5-lower-assembly-timing-rod>

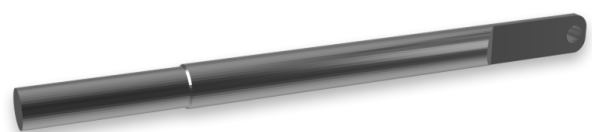

### **Lower Drift Pin Assembly (#AEC0011)**

The Lower Drift Pin Assembly is located below the base of the tablet. It holds the Lower Punch in place in the Die while the Upper Punch pushes down to form the tablet in the middle. Order at <https://www.lfatabletpresses.com/tdp5-lower-pin-assembly>

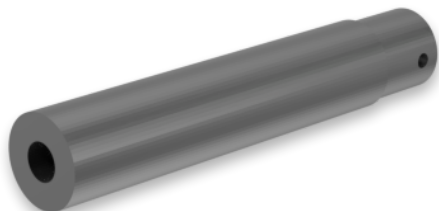

### **Cam Drive Cog (#AEC0050)**

The Cam Drive Cog is attached to the Top Cam Drive Shaft and drives the Lower Drift Pin Assembly Timing Rod. Order at <https://www.lfatabletpresses.com/tdp5-cam-drive-cog>



### **Upper Drift Pin Assembly Locking Nut (#AEC0006)**

The Upper Drift Pin Assembly Locking Nut is a large nut used to secure the Upper Drift Pin Assembly in place. Order at <https://www.lfatabletpresses.com/tdp5-upper-drift-pin-locking-nut>

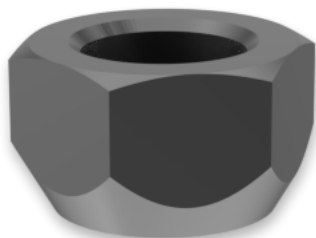

### **Pinion Gear (#AEC0022)**

The Pinion Gear amps up the Motor's torque to get the maximum amount of force available. Order at <https://www.lfatabletpresses.com/tdp5-pinion-gear>

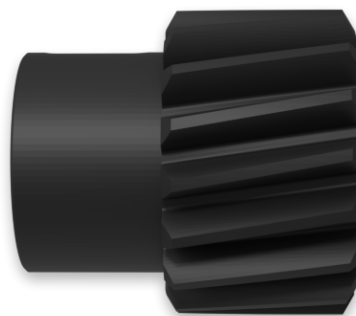

### **Boot Timing Drive Bar Runner (#AEC0022)**

The Boot Timing Cam Runner is a round section that connects the Boot Timing Cam to the Boot Timing Bar, which keeps the timing. Order at <https://www.lfatabletpresses.com/tdp5-boot-drive-runner>



### **Lower Drift Pin Assembly Timing Rod Runner Bolt (#AEC0015)**

The Lower Drift Pin Assembly Timing Rod Runner Bolt connects the Lower Drift Pin Assembly Timing Rod to the Cam Drive Cog. Order at <https://www.lfatabletpresses.com/tdp5-lower-assembly-timing-rod-runner-bolt>



### **Motor (#AEC0042)**

The Motor is mounted at the back of the TDP 5<sup>®</sup> Base and can be either 110 v or 220 v. Order at <https://www.lfatabletpresses.com/tdp5-motor>

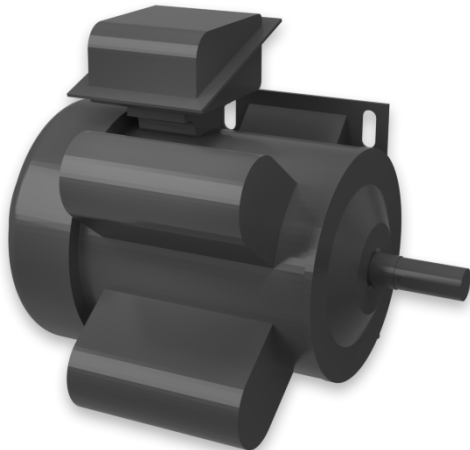

### **Boot Timing Bar (#AEC0018)**

The Boot Timing Bar moves the Boot and is timed by the Boot Timing Cam track. The rocking motion that the arm provides helps the Boot to fill the Die bore with the dry granular material for the next tablet. Order at <https://www.lfatabletpresses.com/tdp5-boot-timing-bar>



### **Lower Drift Pin Assembly Lifting Bar (#AEC0034)**

The Lower Drift Pin Assembly Lifting Bar lifts the Lower Drift Pin Assembly that holds the Lower Punch and helps push the tablets out of the Die. Order at <https://www.lfatabletpresses.com/tdp5-lower-pin-lifting-bar>

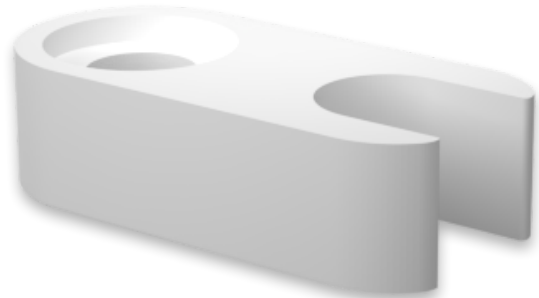

### **Base Plate (#AEC0008)**

The Base Plate is not only the mount for the Boot, but also holds the Die in place. Order at <https://www.lfatabletpresses.com/tdp5-base-plate>



### **Electrical Box and Connecting Cables (#AEC0053)**

The Electrical Box has the On/Off buttons, which are connected to the motor and an electrical plug via cables. Order at <https://www.lfatabletpresses.com/tdp5-electrical-box-wires>

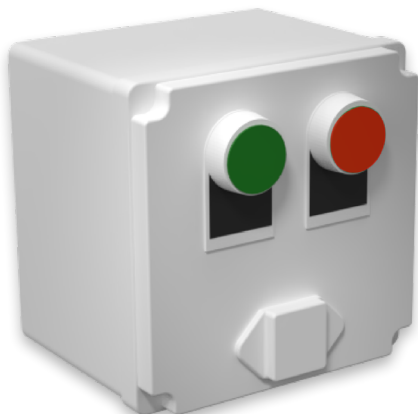

**Drive Belt Pulley (#AEC0043)**

This Drive Belt Pulley fixes on the Motor's keyed axle and has grooves that the V Belt fits into. The V Belt is also connected to the Electrical Drive Flywheel. Order at <https://www.lfatabletpresses.com/tdp5-drive-belt-pulley>

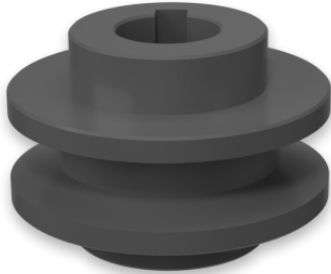

**Lower Drift Pin Assembly Timing Rod Runner (#AEC0016)**

The Lower Drift Pin Assembly Timing Rod Runner is inserted onto the Lower Drift Pin Assembly Timing Rod Runner Bolt and rests in the Cam Drive Cog. Order at <https://www.lfatabletpresses.com/tdp5-lower-assembly-timing-rod-runner>



**Ejection Guard (#AEC0009)**

The Ejection Guard rests in a groove on the Base Plate between the Lower Drift Pin Assembly Timing Rod and the Die. Order at <https://www.lfatabletpresses.com/tdp5-ejection-guard>

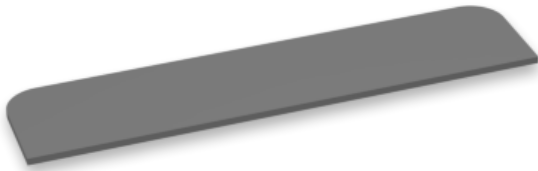

**Ejection Tray (#AEC0049)**

The Ejection Tray aids with the ejection of finished tablets. Order at <https://www.lfatabletpresses.com/tdp5-ejection-tray>

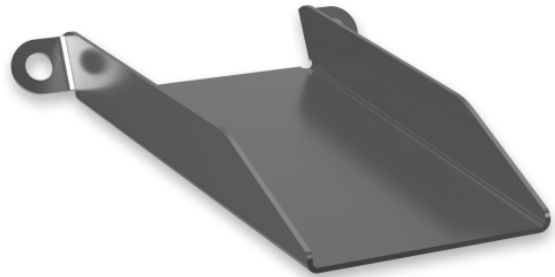

**Upper Drift Pin Assembly Mounting Block (#AEC0010)**

The Upper Drift Pin Assembly Mounting Block holds the Lower Drift Pin Assembly Timing Rod and the Upper Drift Pin Assembly. Order at <https://www.lfatabletpresses.com/tdp5-upper-drift-pin-mounting-block>



**Cam Drive Cog Safety Cover (#AEC0044)**

The Cam Drive Cog Safety Cover prevents users from coming into contact with the moving Cam Drive Cog. Order at <https://www.lfatabletpresses.com/tdp5-cam-drive-cog-cover>

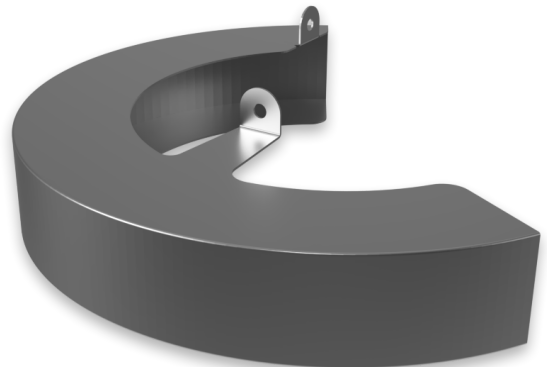

### **Hand Wheel Cap**

The Hand Wheel Cap is fixed onto the Hand Wheel's end. Order at <https://www.lfatabletpresses.com/tdp5-fly-wheel-cap>

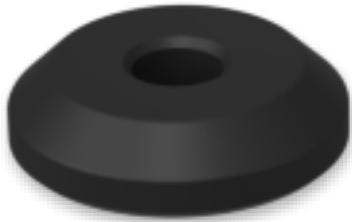

### **Hand Wheel (#AEC0046)**

The Hand Wheel can be used to turn over the TDP 5<sup>®</sup> manually. Order at <https://www.lfatabletpresses.com/tdp5-fly-wheel>



### **Rear Enclosure Plate (#AEC0045)**

The Rear Enclosure Plate is located at the back of the TDP 5<sup>®</sup> Base and prevents dust powder collecting in the interior. Order at <https://www.lfatabletpresses.com/tdp5-rear-enclosure-plate>

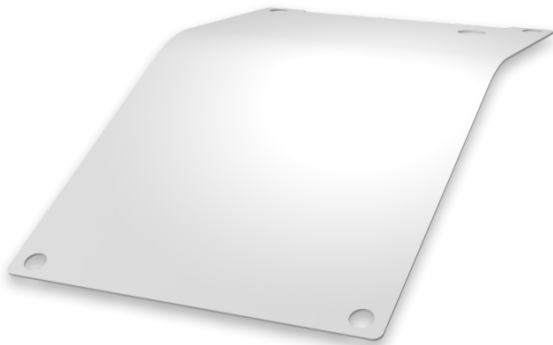

### **Motor Mounting Plate (#AEC0041)**

The Motor Mounting Plate is hinged and connects the Motor to the TDP 5<sup>®</sup> Base. It can be moved to adjust the tension of the V Belt. Order at <https://www.lfatabletpresses.com/tdp5-motor-mounting-plate>



### **V Belt (Drive Belt) (#H108012028)**

The V Belt connects the Motor to the TDP 5<sup>®</sup>'s running parts. Order at <https://www.lfatabletpresses.com/tdp5-v-belt-drive-belts>



### **Hopper Holder (#AEC0035)**

The Hopper Holder is a small bar that secures the Hopper in place. Order at <https://www.lfatabletpresses.com/tdp5-hopper-holder>

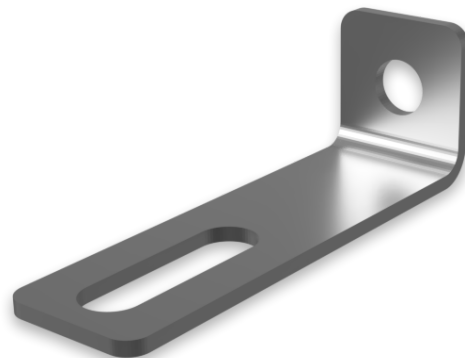

## List of Electrical Components

Name of Part	Part Manufacturer	Part Serial Number	Quantity	Link to Manufacturer's Site
Red Switch	Rockwell Automation	800FD-F4X11	1	<a href="#">Rockwell Automation</a>
Green Switch	Rockwell Automation	800FD-F4X11	1	<a href="#">Rockwell Automation</a>
3 Phase AC Socket with Dust Cover	Guanghua Electronic Mall/ Dunhua Electronic Materials Co., Ltd.	6214CAP	1	<a href="#">Guanghua Electronic Mall/ Dunhua Electronic Materials Co., Ltd.</a>
Contactors	Rockwell Automation	100-C09KF01	1	<a href="#">Rockwell Automation</a>
Plastic Power Box	Yueqing Mingzhou Electric Co., Ltd.		1	<a href="#">Yueqing Mingzhou Electric Co., Ltd.</a>

## Material of Contact Parts

Contact Part	Material
Boot	MABS (Terlux HD 2822) plastic
Base Plate	S45C carbon steel
Tooling (Upper Punch, Lower Punch, and Die)	User specified
Ejection Tray	SUS304 stainless steel
Hopper	Polypropylene (PP) plastic

## Technical Specifications

Number of dies	1
Max production capacity	4800/hour
Max diameter of tablet	20 mm
Max thickness of tablet	8 mm
Max fill depth	18 mm
Max pressure	50 kN
Number of filling stations	1
Double layered tablet	No
Motor power	0.75 kW
Number of phase	1
Amps	5.7 A @ 240 V; 11 A 110 V; 5.5 A @ 220 V
Volts	240 V (110 V and 220 V on request)
Overall size	800 mm x 400 mm x 700 mm
Dimensions with suggested working clearance	1700 mm x 1300 mm x 1600 mm
Weight	125 kg (275 lbs)

# Maintenance Checklist

<b>Before Operation</b>	
<input type="checkbox"/>	Visually inspect the tablet press and the parts.
<input type="checkbox"/>	Ensure all locking nuts are tight.
<input type="checkbox"/>	Visually inspect grease nipples and regrease where necessary.
<input type="checkbox"/>	Tune the tablet press by hand to get the tablet size and weight correct.
<input type="checkbox"/>	Manually operate the machine for at least two full rotations to ensure it is not jammed.
<b>During Operation</b>	
<input type="checkbox"/>	Listen for irregular knocking or clicking sounds. If heard, stop operation and lubricate the desktop press.
<input type="checkbox"/>	Watch for buildup of powder in front of the Boot. If occurring, either (a) make mix more granular, (b) check the Boot's base for damage, or (c) clear the buildup with a paintbrush.
<input type="checkbox"/>	Occasionally check the Motor's temperature. If it starts to overheat, turn off the machine, let it cool down, and grease it to ensure smooth operation.
<input type="checkbox"/>	Ensure that the Hopper does not run out of powder.
<input type="checkbox"/>	Weigh a sample tablet and test for its hardness.
<b>After Operation</b>	
<input type="checkbox"/>	Unplug machine and remove all excess powder with a bagless vacuum.
<input type="checkbox"/>	Remove the Boot and the Tooling and clean the inside of the tablet press.
<input type="checkbox"/>	Wipe down the other surfaces with a damp cloth.
<input type="checkbox"/>	Apply a layer of food grade grease to the entire desktop tablet press.
<input type="checkbox"/>	Lubricate all grease nipples.
<input type="checkbox"/>	Store Tooling in an airtight box with a small amount of grease.

# Diagrams

## TDP 5® Dimensions

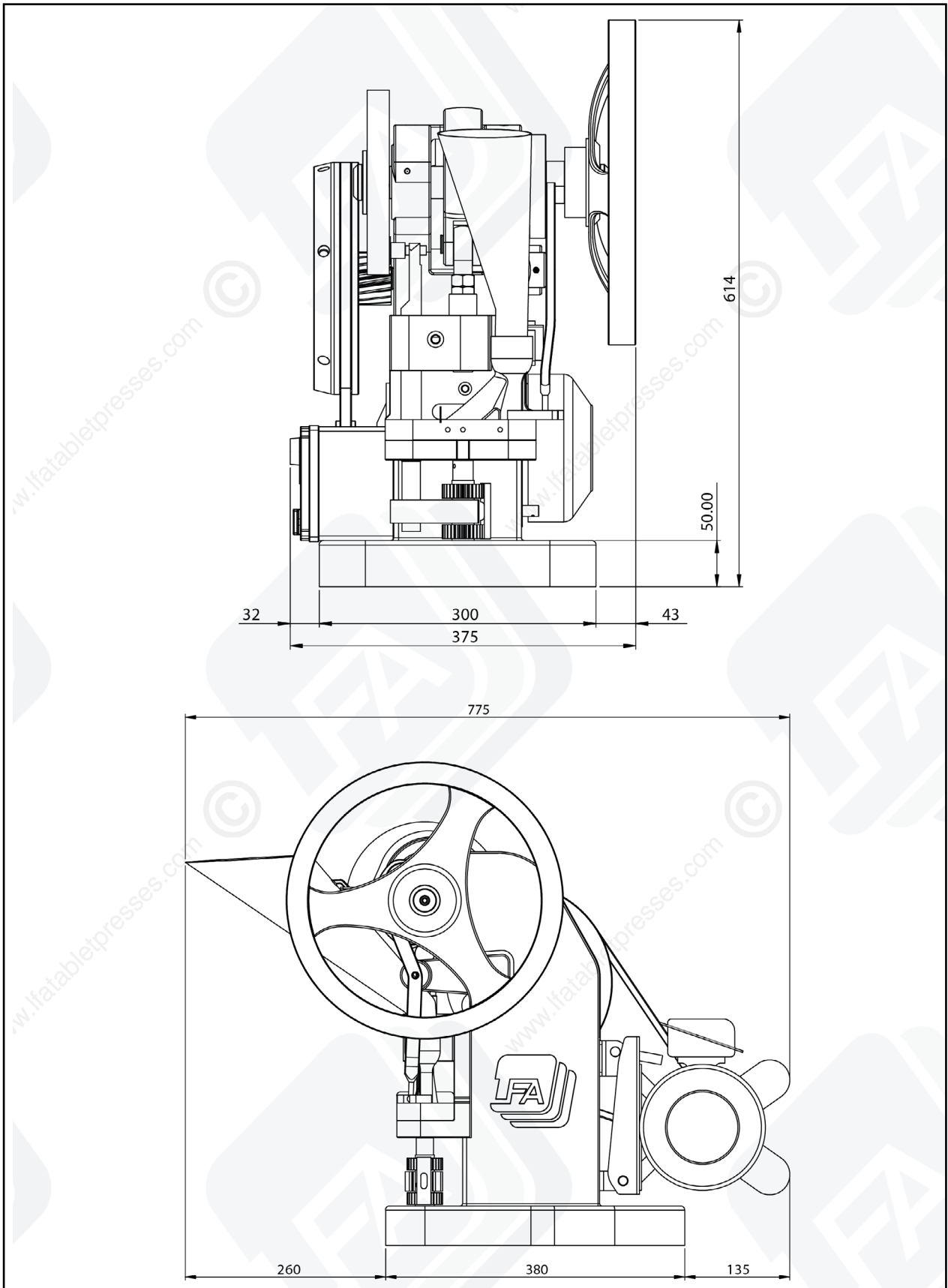



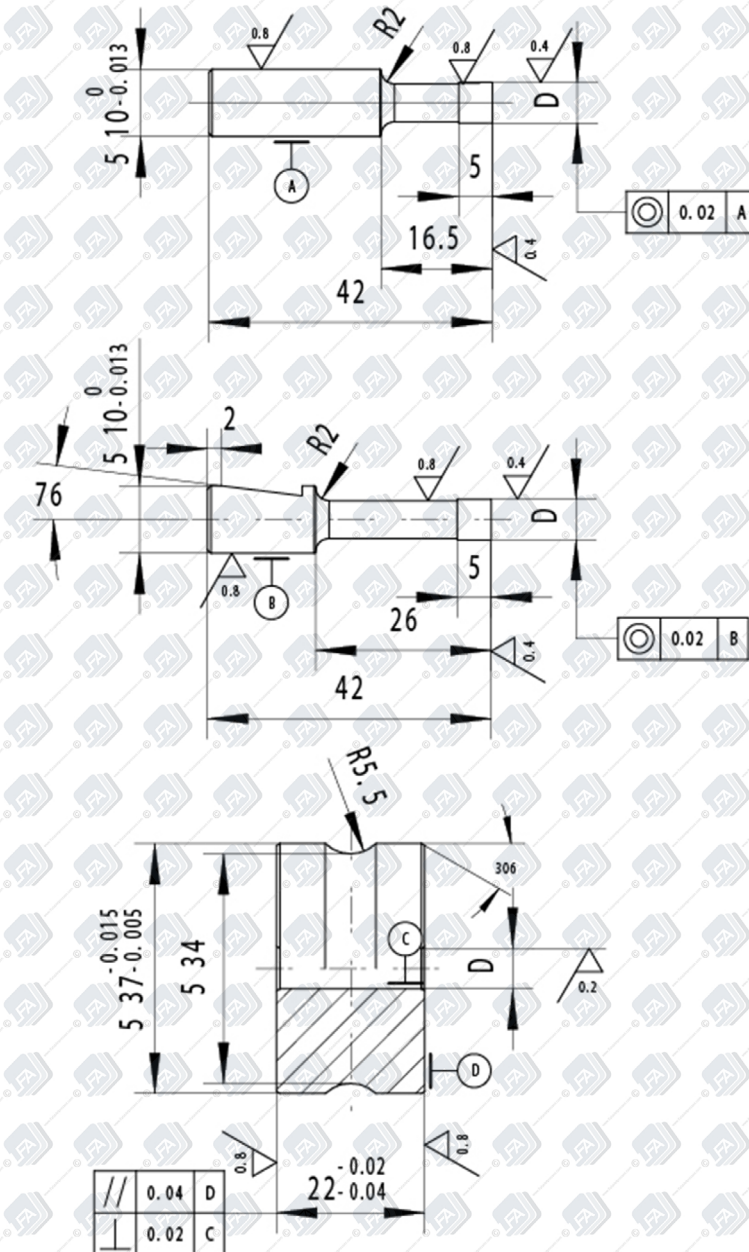

# TDP® International Tooling Standard Dimensions

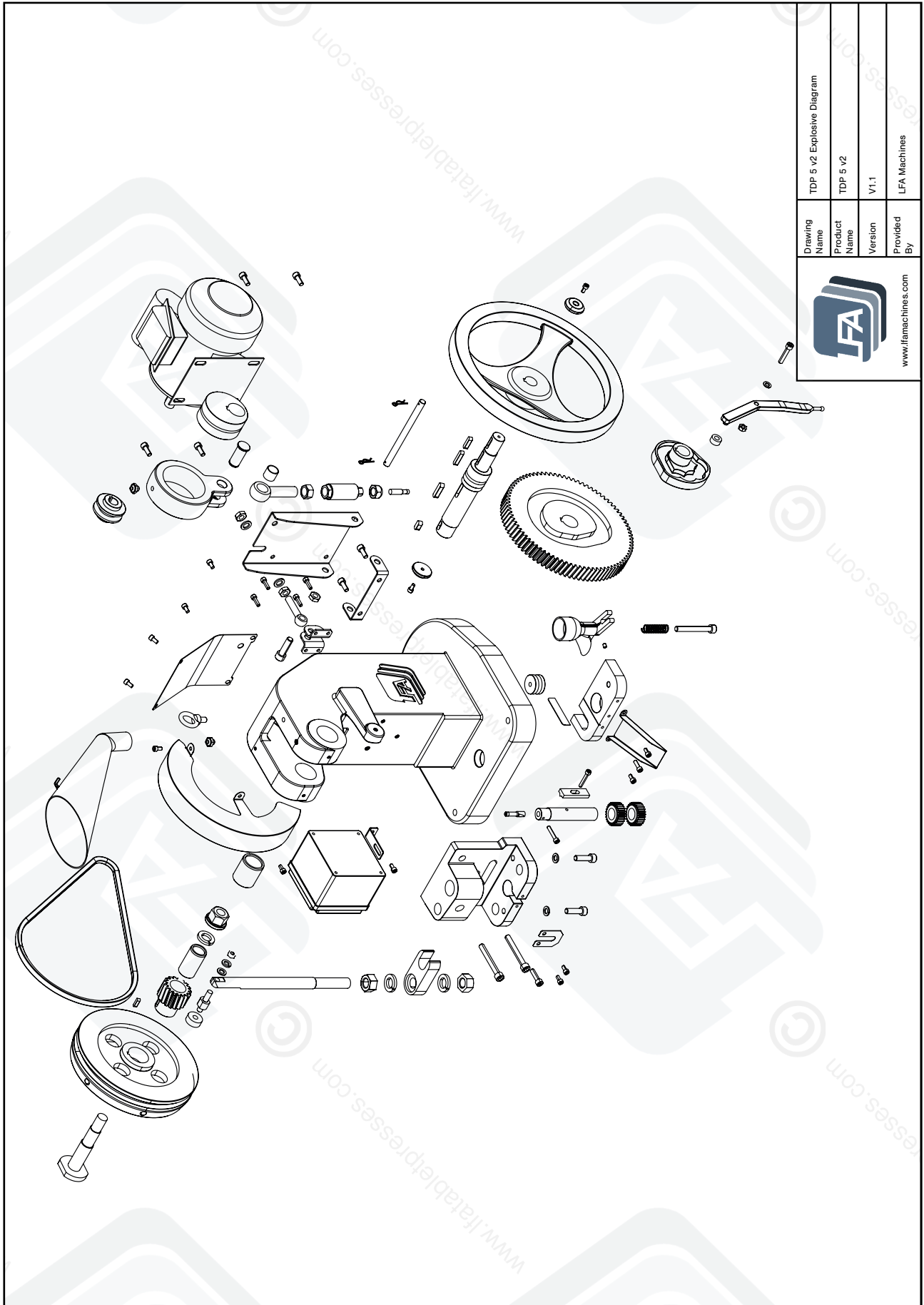

[www.lfatabletpresses.com](http://www.lfatabletpresses.com)

# TDP 5® Exploding Diagram



	Drawing Name	TDP 5 v2 Explosive Diagram
<a href="http://www.lfamachines.com">www.lfamachines.com</a>	Product Name	TDP 5 v2
	Version	V1.1
	Provided By	LFA Machines

# TDP 5® Wiring Diagram

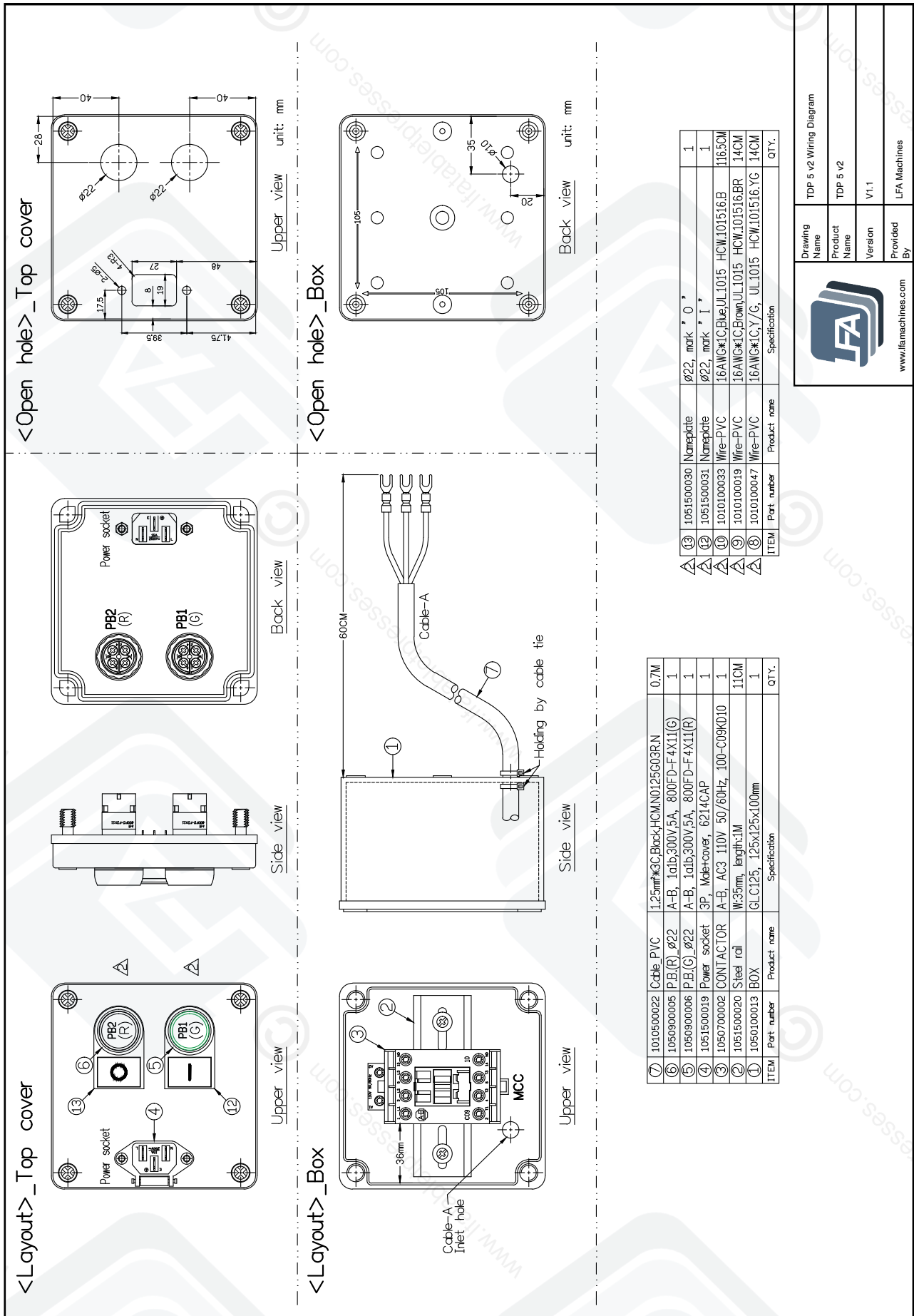

www.lfa-machines.com

Drawing Name	TDP 5 v2 Wiring Diagram
Product Name	TDP 5 v2
Version	V1.1
Provided By	LFA Machines

# TDP 5® Wiring Diagram

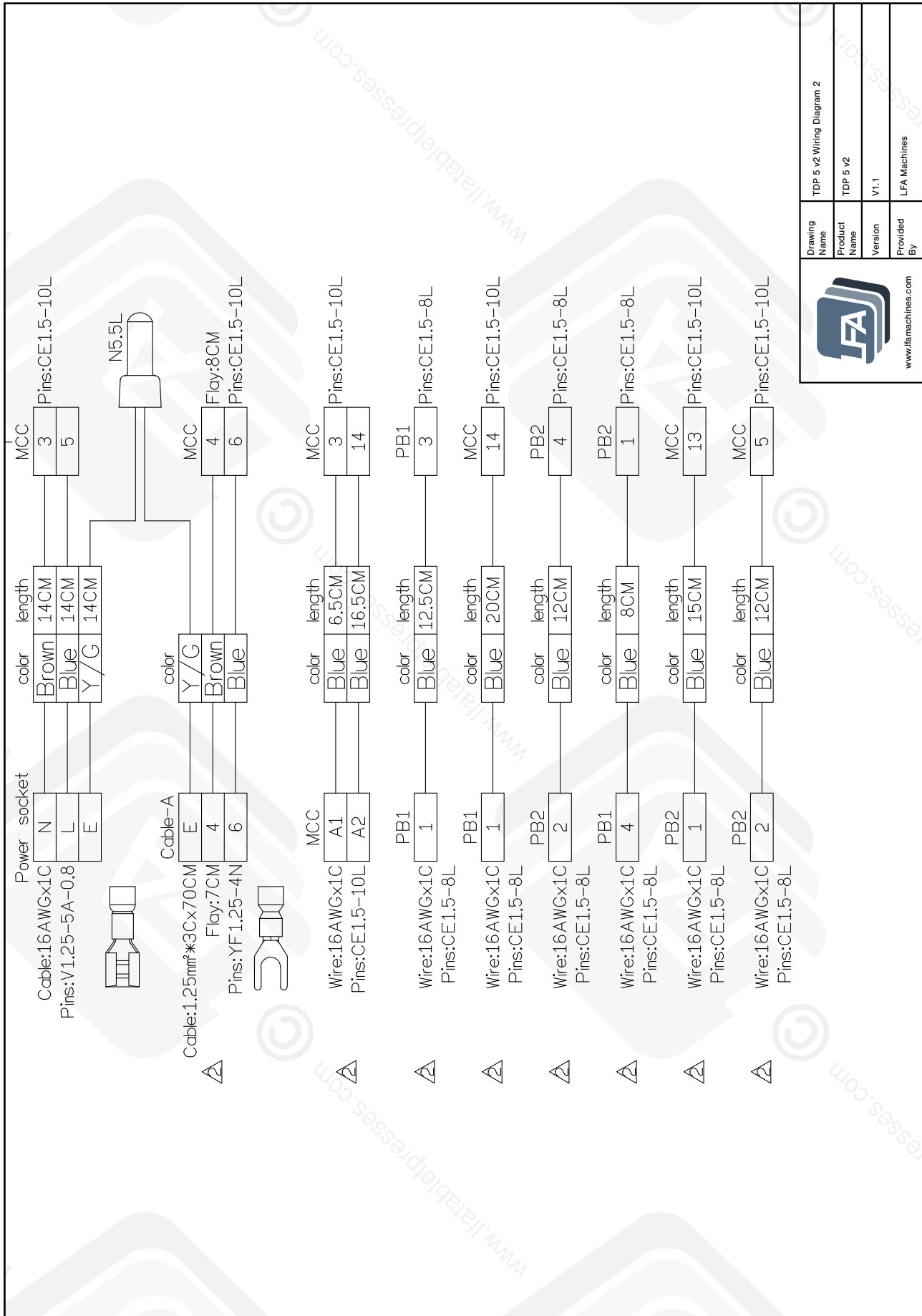

	Drawing Name	TDP 5 v2 Wiring Diagram 2
	Product Name	TDP 5 v2
	Version	V1.1
	Provided By	LFA Machines

# TDP 5® Mounting Diagram

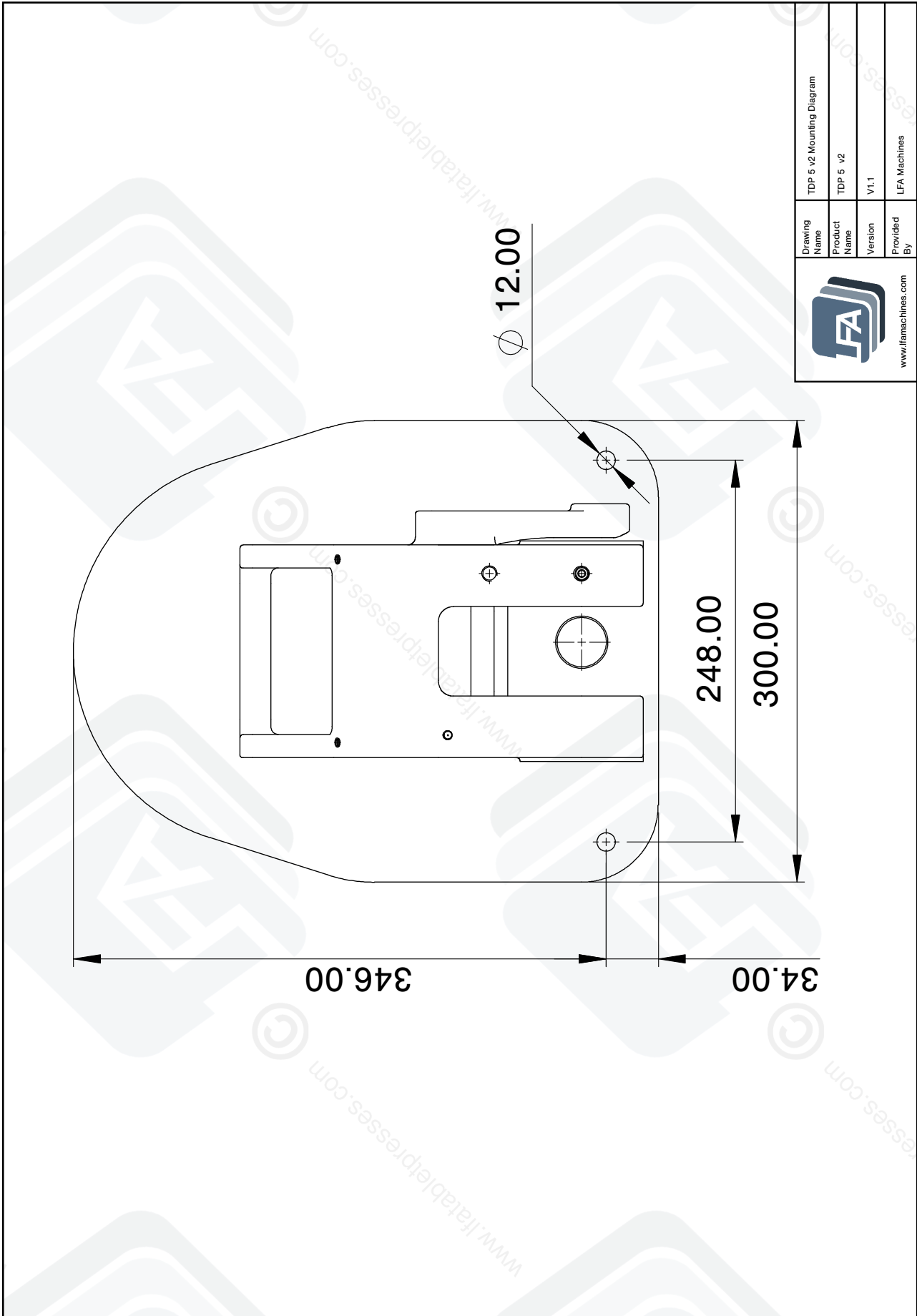

# Resources

## Helpful Links

### Warranty

For information regarding the warranty policy of the TDP 5<sup>®</sup> and other LFA products, please visit <https://www.lfatabletpresses.com/warranty>

### LFA Website

In order to aid you in your tablet production, LFA Machines maintains a website that offers a breadth of useful information about the TDP 5<sup>®</sup> and other tablet presses. Use our online tools such as the Tablet Mix Calculator to help you in your formulation production or read our regularly published articles that cover a whole range of topics about tablet presses and tablet production.

Visit the LFA homepage at <https://www.lfatabletpresses.com>

### LFA Machines YouTube Channel

Our YouTube videos provide you an opportunity to see how to use our tablet presses, common troubleshooting tips, and other LFA products such as capsule fillers and mixers. We regularly upload videos to give you a visual aid that will hopefully support you in your tablet production efforts. To watch our videos, visit <https://www.youtube.com/channel/UCwtbcwja77ai7vX2o34FUkQ>

### LFA Machines Social Media

Social media is a great way to keep yourself updated on new developments and exciting things happening at LFA Machines. The list below contains our current social media pages:

Twitter: @lfatabletpress

Instagram: @lfatabletpresses

Facebook: <https://www.facebook.com/lfatabletpresses>

LinkedIn: <https://www.linkedin.com/company/lfa-machines-oxford-ltd/>

## Contact Us

### UK

LFA Machines Oxford Ltd  
Unit 4B Rowood Estate  
Murdock Road  
Bicester, Oxfordshire OX26 4PP  
+44 01869 250234  
[support.uk@lfamachines.com](mailto:support.uk@lfamachines.com)  
Monday-Friday  
9AM-5PM GMT

### USA

LFA Machines DFW, LLC  
6601 Will Rogers Blvd  
Fort Worth, TX 76140  
+1 (682) 312 0034  
[support.usa@lfamachines.com](mailto:support.usa@lfamachines.com)  
Monday-Friday  
8AM-6PM UTC (Central)

### Germany

LFA Machines Düsseldorf GmbH  
Business Parc Am Trippelsberg 92  
Düsseldorf, North-Rhine  
Westphalia 40589  
+41 21188250223  
[verkauf@lfamachines.com](mailto:verkauf@lfamachines.com)

### Taiwan

LFA Machines Taiwan Ltd  
7F-5, No. 2, Sec. 2 Taiwan Blvd  
West District, Taichung City 403  
Taiwan  
+886 422031790  
[support.asia@lfamachines.com](mailto:support.asia@lfamachines.com)  
Monday-Friday  
9AM-5PM GMT+8





LFA MACHINES

Copyright © 2022 by LFA Machines

[www.lfamachines.com](http://www.lfamachines.com)

**United Kingdom**

Unit 4B  
Murdock Road  
Bicester  
Oxfordshire  
United Kingdom  
OX26 4PP

**United States**

6601 Will Rogers Blvd  
Fort Worth  
Texas  
United States  
76140

**Germany**

Business Parc Am  
Trippelsberg 92  
Düsseldorf  
Germany  
40589

**Taiwan**

7F.-5, No. 2, Sec. 2  
Taiwan Blvd., West Dist.,  
Taichung City 403,  
Taiwan