



UHDD™ Tablet De-Duster User Manual



We don't just sell machines—
we provide service.

Copyright Notice

© LFA Machines Oxford Limited, published in 2023 by LFA Machines Oxford Limited 2023. Registered in England and Wales, company number 08428898, registered office for service Demar House 14 Church Road East Wittering, Chichester, West Sussex, PO20 8PS.

All rights reserved. No part of this publication may be reproduced or transmitted, in any form or by any means, or stored in any retrieval system of any nature, without prior permission, except for fair dealing under the Copyright, Designs and Patents Act 1988, or in accordance with the terms of license issued by the Copyright Licensing Agency in respect of photocopying and/or reprographic reproduction. Application for permission for other use of the copyright material including permission to reproduce extracts in other published works shall be made to the publisher. Full acknowledgment of author, publisher and source must be given.

All trade marks are acknowledged and are owned by their respective owners.

Important Safety Information

READ THIS BEFORE OPERATING MACHINE

Intended Use

The intended use of this machine is to remove excess powder from tablets after pressing.

Potential misuse of this machine includes:

- Inserting tablets into the discharge chute at the top rather than the feeder at the bottom.
- Not properly mounting the machine.
- Using wet or damp material.

Personal Protection

For personal protection while transporting the UHDD™, abide by these actions:

- Wear steel toe boots to prevent foot injury.
- Wear heavy duty grip gloves to ensure firm grasp on machine.
- Wear back support belt to prevent injury if needed.

For personal protection while operating the UHDD™, abide by these actions:

- Avoid wearing loose jewelry to prevent machine entanglement.
- Contain long hair to prevent machine entanglement.
- Wear safety goggles.
- Wear ear protectors
- Wear disposable latex/rubber gloves.
- Wear a hairnet (food grade products only).
- Wear a beard net if needed (food grade products only).

General Hazards

- Be aware of risk of entanglement and pinch point due to moving parts.
- Do not operate in a wet environment or with wet hands due to risk of electrical shock or burn.
- Do not operate if any wires are damaged, pinched, or frayed due to risk of electrical shock or burn.
- Keep out of reach of children.
- Keep fingers away from all moving parts.
- Inspect machine before use.
- Check that nuts and bolts are suitably tightened.
- Use this machine only for its intended use as described in this manual.
- Turn off and unplug the machine before conducting cleaning and maintenance.
- Do not modify the machine in any way.

Safety Assessment

It is critical to conduct a safety assessment to ensure that it complies with all local laws and industry accepted safety regulations.

If you require guidance on the installation of the machine or conducting a safety assessment, please contact LFA Machines.

Important Safety Information

READ THIS BEFORE OPERATING MACHINE

Symbols



WARNING

This signals potential risk for personal injury.



WARNING

This signals potential risk for electrical shock.



CAUTION

This signals potential risk for damage to the machine or other parts.

Modes for Stopping

In the case of an emergency during operation, immediately unplug and/or push the Emergency Stop button.



Prop. 65 Statement for CA Residents

Based on LFA's current level of knowledge of our machines, the UHDD™ does not require a Proposition 65 warning label.

Warning for Explosive Material

This machine is not explosion proof. LFA recommends that you test your materials' explosivity before running them through this machine. If your materials are indeed explosive, do not use them with this machine.

Table of Contents

Copyright Notice	2
Important Safety Information	3
Intended Use	3
Personal Protection	3
General Hazards	3
Safety Assessment	3
Symbols	4
Modes for Stopping	4
Prop. 65 Statement for CA Residents	4
Warning for Explosive Material	4
UHDD™ Parts List	7
Preface	8
Training	9
Off-Site Training	9
Training via Video Chat/Phone	9
LFA Articles	9
LFA Videos	9
Installation	10
Tools and Materials Needed	10
The Appropriate Workstation for the Machine	10
Positioning the UHDD™	12
Assembly	13
Controls	14
Settings and Adjustment	17
Maintenance	21
General Maintenance Prescriptions	21
Repair and Replacement	21
Troubleshooting	22
Common Machine/Part Issues	22
De-Jamming the UHDD™	23
Cleaning	25
Storing the UHDD™	28
Appendix	28
Glossary	28
Description of UHDD™ Parts	29
Material of Contact Parts	31
Technical Specifications	31
Maintenance Checklist	32
Resources	35

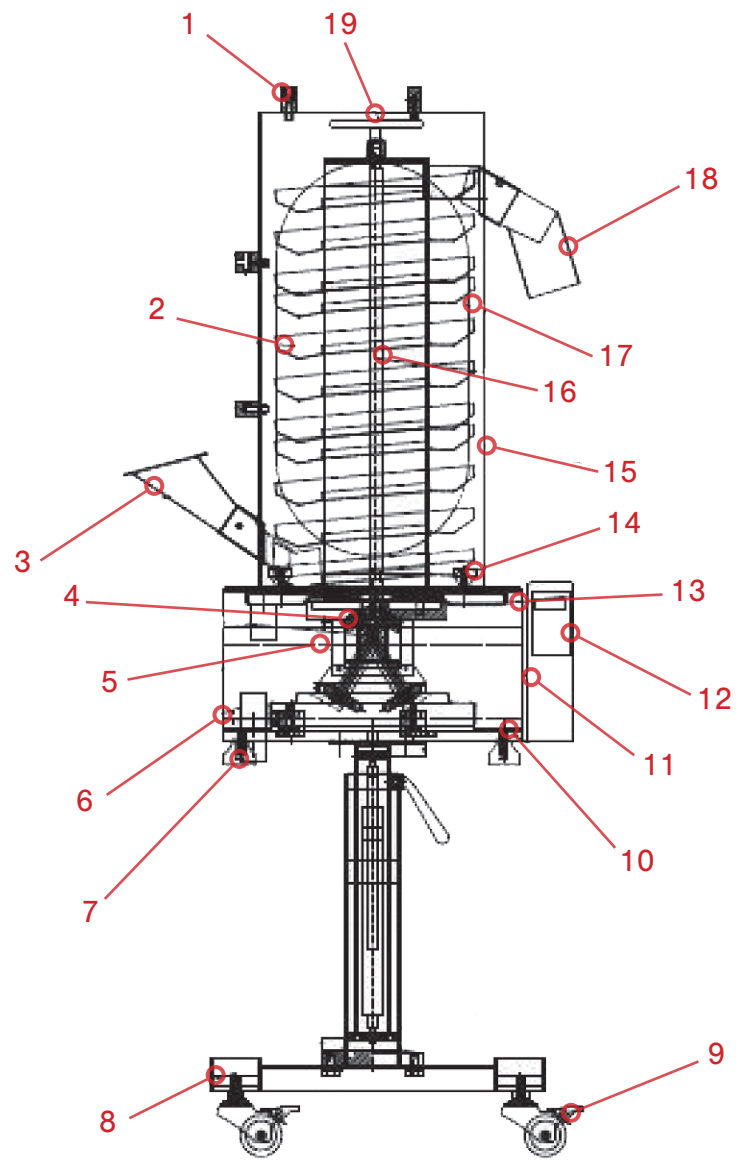

UHDD™ Parts List

- 1. Air Mounting**
- 2. Sifter**
- 3. Tablet Feeder**
- 4. Vibratory Component**
- 5. Electromagnet**
- 6. Suction Pipe Port**
- 7. Lower Cover Knob**
- 8. Moveable Stand**
- 9. Caster**
- 10. Base Board**
- 11. Cover**
- 12. Vibration Controller**
- 13. Powder Collection Plate**
- 14. Upper Cover Knob**
- 15. Sifter Outer Cover**
- 16. Locating Rod**
- 17. Window**
- 18. Discharge Chute**
- 19. Locking Nut**

Preface



The UHDD™ Tablet De-Duster removes excess powder from tablets after pressing. This machine can be connected to a tablet press so that the tablets pour into the de-duster right after being pressed. Using compressed air, the UHDD™ features an efficient agitation mechanism that removes powder while keeping the tablets intact and undamaged. Easy to install and maintain, this machine also has adjustable speed and wheels for easy integration and movement.

The purpose of this document is to support your understanding of the UHDD™'s components, features, functions, and design. With this manual, you will be able to successfully operate and maintain your UHDD™ machine.

The user manual's content includes:

- Important safety information
- UHDD™ installation instructions
- Description of the UHDD™'s operation
- UHDD™ maintenance information
- Appendix with supplemental information

Training

UHDD™ training is essential for the machine's successful operation and your personal safety. There are several methods to prepare you for working with the UHDD™.

Off-Site Training

LFA offers free training at our UK, USA, and Taiwan facilities for all our customers and their teams. For more information, go to <https://www.lfatabletpresses.com/services>

Training via Video Chat/Phone

Using an online video chat system, an LFA technician can interact face-to-face with you and assist with your understanding of the machine. Or, if you prefer, LFA can provide training via phone for all customers who call the office. To set up a training, call or email your local LFA office:

UK

Phone

+44 01869 250234

Email

support.uk@lfamachines.com

USA

Phone

+1 (682) 312-0034

Email

support.usa@lfamachines.com

Taiwan

Phone

+886 422031790

Email

support.asia@lfamachines.com

LFA Articles

LFA writes informative articles about our machines, which includes instructions, procedures, and guides. To access the articles, go to <https://www.lfatabletpresses.com/articles>

LFA Videos

LFA has created videos involving the UHDD™ and other machines. To access the videos, go to <https://www.lfatabletpresses.com/videos> or <https://www.youtube.com/user/TabletPilPress>

Installation

Tools and Materials Needed

Before you install and operate the UHDD™, it is best to have the following tools and materials on hand for general operation and maintenance:

- Hammer
- Crowbar
- Engine hoist or lift with lifting strap
- Metric wrench set and adjustable wrench
- Flathead screwdriver
- Set of metric Allen keys with ball ends
- Long wire pipe cleaner
- Lubricant (NSF approved for food grade products)
- Bagless vacuum
- Dust collector vacuum (e.g. LFA's TabVac Tablet Dust Vacuum, which can be purchased at <https://www.lfatabletpresses.com/tabvac-tablet-dust-vacuum>)
- Air compressor
- Quick connect male fitting for air compressor
- Sanitizer (e.g. Member's Mark Commercial Sanitizer)
- Plastic sheet or something similar to cover machine
- Ear protectors
- Safety goggles
- Disposable latex/rubber gloves
- Hairnet and/or beard net (food grade products only)
- Sterile shoe covers (food grade products only)

The Appropriate Workstation for the Machine

Find stable, even flooring that supports the UHDD™'s 70 kg (approximately 154 lbs) weight. This machine also has a single phase 110 V - 240 V ($\pm 10\%$) electrical requirement, so ensure that it is near an appropriate power plug.

Environmental Conditions

It is important that the environment in which you operate and store the UHDD™ has the appropriate temperature and relative humidity levels. These two environmental factors can potentially cause the machine to rust and/or cause the tablets to have a lower quality. The table below shows the acceptable temperature and relative humidity levels:

Machine	Temperature		Humidity
	°C	°F	
UHDD™	18-24	64-75	45-65% RH

The shipping crate will contain the following:

1. The fully assembled UHDD™



2. Corrugated tube and electrical wires.

2.1 Note: The wheels at the bottom might need to be screwed on.

Unpacking the UHDD™

Tools Needed

- Hammer
- Crowbar

Instructions

1. Pry open the panels of the shipping container with a hammer and crowbar.



2. Lift the top of the shipping container from its base.
3. Remove the plastic wrapping.
 - 3.1 Note: Save the wrapping for future transport and/or storage.

Positioning the UHDD™

WARNING: To prevent personal injury, wear steel toe boots and heavy duty grip gloves while transporting the UHDD™.



One or two people should be sufficient in removing the machine from the shipping container and positioning it in the workspace.

To safely transport the UHDD™, wrap the machine with a lifting strap and secure it to the engine hoist or lift. Safely guide the machine to the ground. Unlock the wheels at the bottom of the machine and guide to the desired location (near 110 V - 240 V [$\pm 10\%$] electrical plug). Lock the wheels after moving. Use the adjustable stand to raise or lower the machine.



Assembly

The UHDD™ comes fully assembled with a few minor installations.

Tools Needed

- Engine hoist or lift and lifting strap (if wheels are not attached)
- Dust collector vacuum (e.g. LFA's TabVac Tablet Dust Vacuum, which can be purchased at <https://www.lfatabletpresses.com/tabvac-tablet-dust-vacuum>)
- Air compressor
- Quick-connect male fitting for air compressor

Instructions

1. Connect the corrugated tube to the Feeder if the machine is to be connected with a rotary tablet press.
2. Connect the electrical wires to the machine next to the ON/OFF button.
3. If the wheels are not connected, wrap a lifting strap around the machine and use an engine hoist/lift to raise it. Screw in the wheels through their bolts on the bottom four corners of the machine.
4. Connect the the vacuum to the bottom of the machine.
5. Connect the air hose fittings (comes with machine) to the UHDD™.



6. Connect the machine's air hose to an air compressor with a quick-connect male fitting.



Controls

Basic Components

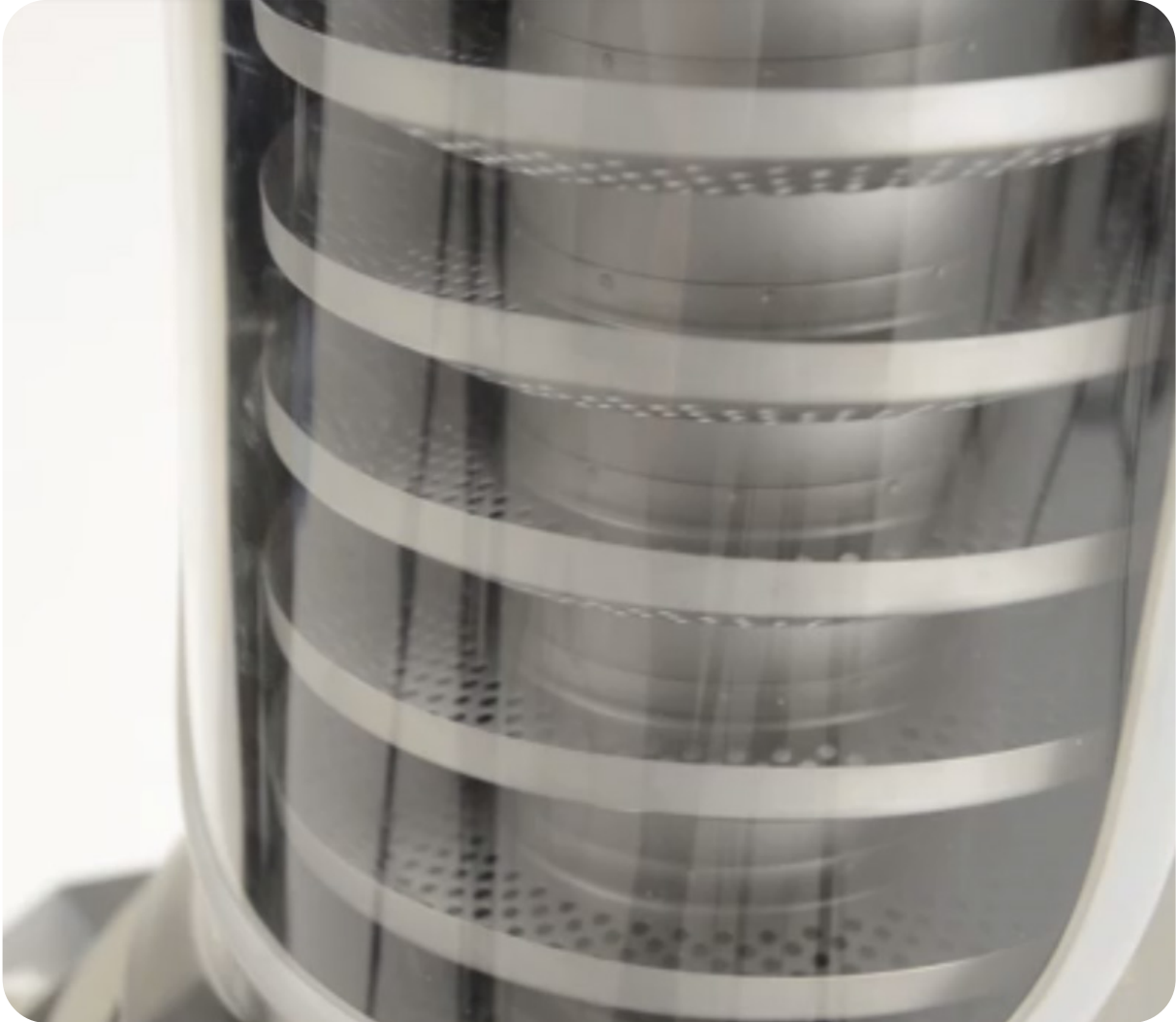

A description of the principal components follows:

- The **Base** contains the electro-magnet and vibratory component that produces the power to move the tablets.
- The **Locating Rod** holds the sifter in place.
- The **Sifter** removes the excess powder and polishes the tablets.

UHDD™ Process

The basic mechanism of the UHDD™ involves using an agitation system to loosen dust from tablets' surface as they pass through the machine.

Charging the Electromagnet

Once the machine is plugged in and turned on, the electromagnet becomes charged, which creates a force that moves the armature down and compresses the vibratory spring.

Movement Caused by Vibration

Once the electromagnet loses its charge, the vibratory spring will move back to its original position. As the armature moves back and forth, it creates a vibratory motion that results in the tablets moving up through the machine.

Removal of Dust by Vibration

While the tablets are being moved upward through the machine, the vibratory power removes the excess dust and produces smooth and clean tablets which are expelled through the discharge chute.

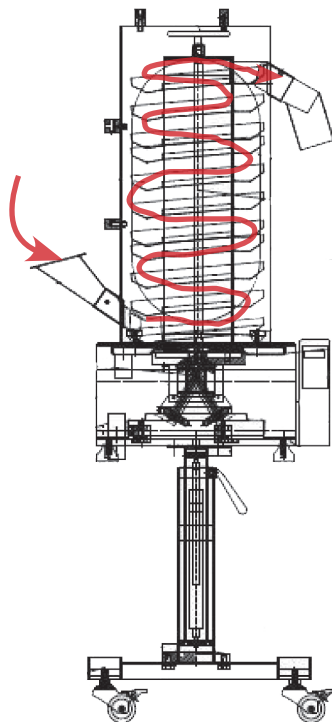

How to De-Dust Tablets with the UHDD™

Tools and Materials Needed

- Tablets with a friability of less than 1%
- UHDD™
- Receptacle to catch de-dusted tablets
- Ear protectors
- Safety goggles
- Disposable latex/rubber gloves (for food grade products and to protect hands from grease)
- Hairnet and/or beard net (food grade products only)
- Sterile shoe covers (food grade products only)



WARNING: For personal protection while operating the UHDD™, contain long hair, do not wear loose jewelry, and wear ear protectors.

Instructions

Note: Wear latex/rubber gloves (and appropriate food grade attire if applicable) and ear protectors during this process.

1. Press the ON button on the control panel.



2. Insert several tablets into the Feeder for a test run.
 - 2.1 Note: Adjust the speed on the machine and watch for any abnormality in operation.
3. Pour the rest of the tablets into the Feeder.

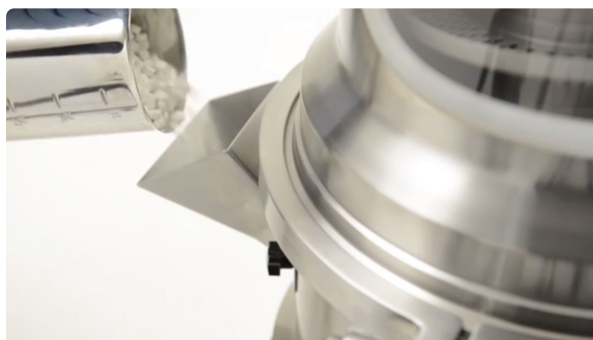

4. Catch the ejected de-dusted tablets from the Discharge Chute at the top of the machine.
5. Lower the operation speed to the minimum and press the OFF button on the control panel whenever all tablets have been de-dusted.

Settings and Adjustment

Operation Speed

The UHDD™ operation speed can be adjusted by turning a dial on the control panel.

Tools and Materials Needed

- Ear protectors
- Safety goggles
- Disposable latex/rubber gloves (for food grade products and to protect hands from grease)
- Hairnet and/or beard net (food grade products only)
- Sterile shoe covers (food grade products only)



WARNING: For personal protection while operating and adjusting the UHDD™, contain long hair, do not wear loose jewelry, and wear ear protectors.

Instructions

Note: Wear latex/rubber gloves (and appropriate food grade attire if applicable) and ear protectors during this process.

1. Press the ON button on the control panel.
2. Pour in the tablets into the machine's feeder.
3. Rotate the dial on the control panel to adjust the operation speed.
 - 3.1 Note: Rotate the dial clockwise to increase the operation speed, and rotate the dial counterclockwise to decrease the operation speed. If tablets are coming out dusty, the machine will need to be slowed down. If the tablets are coming out clean but are becoming backed up in the sifter, the machine will need more speed.



Armature Position

Whenever the connection between the armature and electromagnet becomes weak, the vibratory power of the machine cuts off. Adjusting the position of the armature ensures that it can reconnect to the electromagnet.

Tools and Materials Needed

- Set of metric Allen keys
- Adjustable wrench
- Safety goggles
- Disposable latex/rubber gloves (for food grade products and to protect hands from grease)
- Hairnet and/or beard net (food grade products only)
- Sterile shoe covers (food grade products only)



WARNING: For personal protection while operating and adjusting the UHDD™, contain long hair, do not wear loose jewelry, and wear ear protectors.



WARNING: Always unplug this machine when adjusting the armature. Not doing so may increase the risk of electrical shock.

Instructions

Note: Wear latex/rubber gloves (and appropriate food grade attire if applicable) during this process.

1. Loosen the four knobs on the machine by hand.

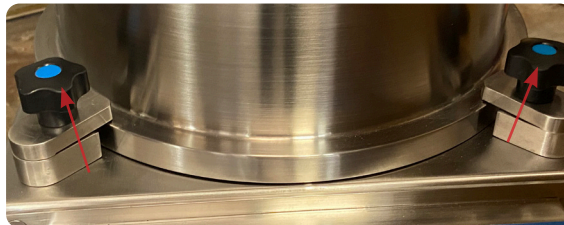

2. Remove the machine's outer cover's outer ring by loosening it by hand.



3. Raise the outer cover carefully over the sifter.

4. Loosen the lock on top of the locating rod and remove the two pieces of the sifter by slightly twisting the two from each other.

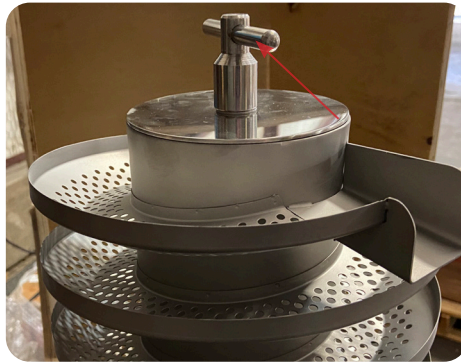

5. Take hold of the locating rod with an adjustable wrench and twist to remove it.

6. Loosen the screws on the plate with an Allen key.

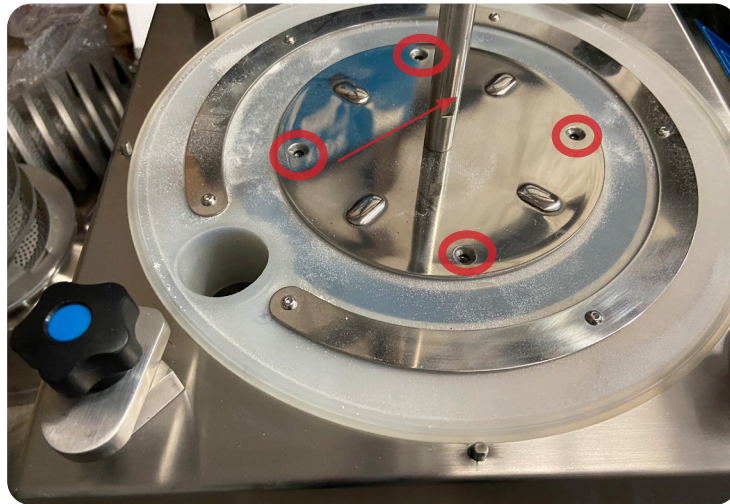

7. Remove the knobs and plug on the bottom of the machine.



8. Raise the electrical parts covering over the machine to reveal the armature, electromagnet, and spring.

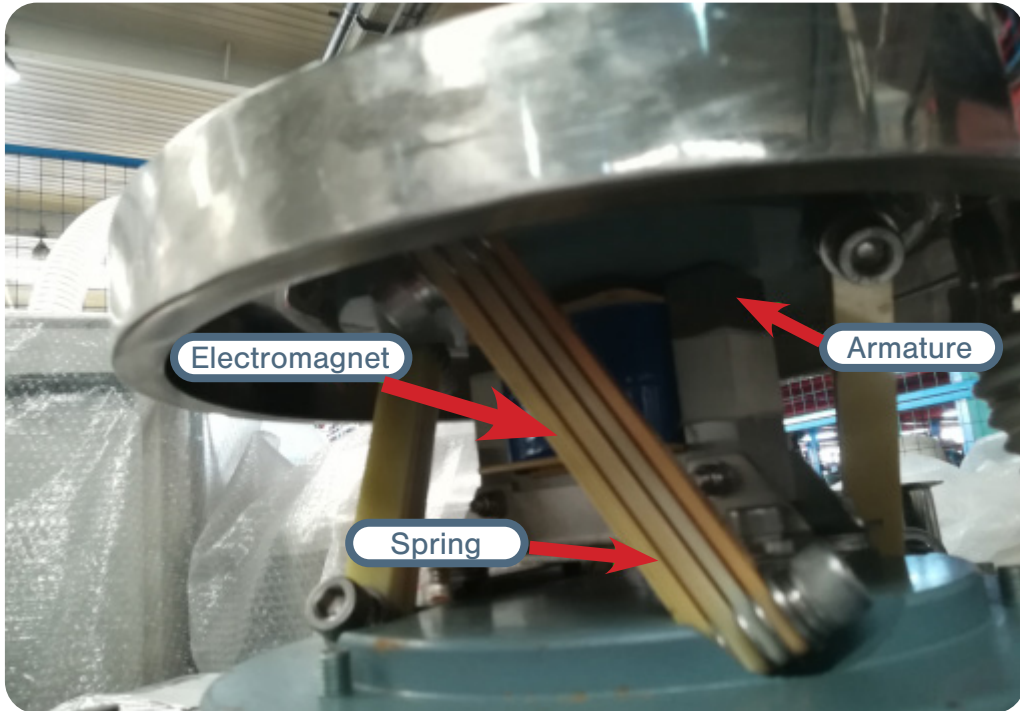

9. Loosen the screws that secure the armature and raise/lower its height.

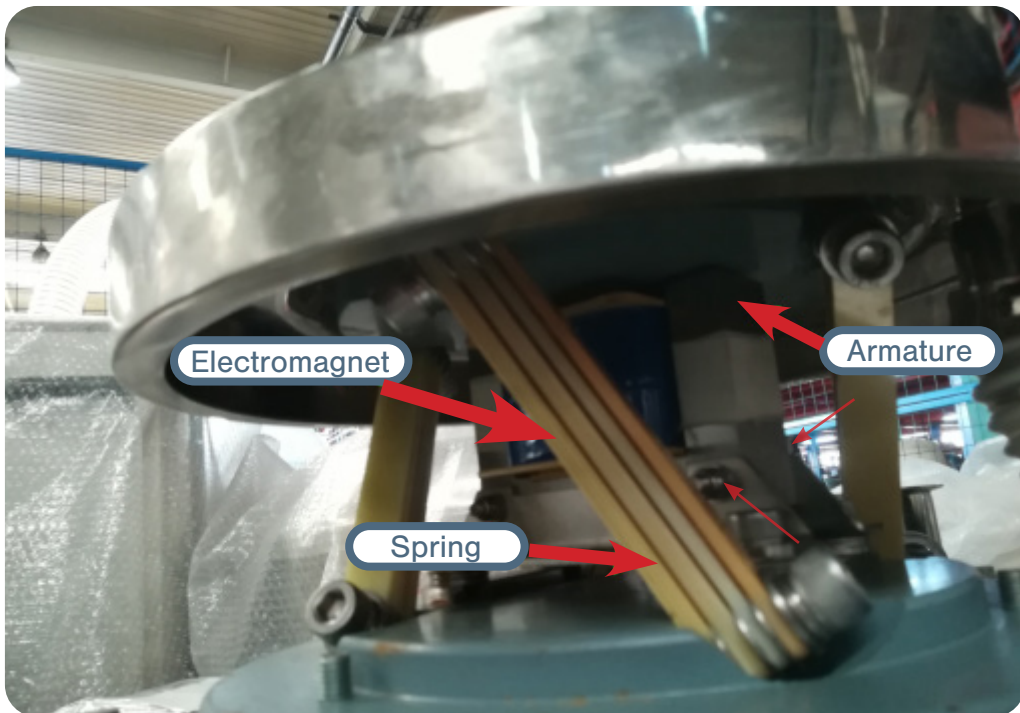

Voltage Calibration

The UHDD™ can be adjusted to run on 110 V, 120 V, 220 V, or 240 V single phase power, meaning it can work with a variety of power supplies. Once you know the power source voltage that is needed, the voltage can be easily adjusted.

Tools and Materials Needed

- Safety goggles
- Disposable latex/rubber gloves (for food grade products and to protect hands from grease)
- Hairnet and/or beard net (food grade products only)
- Sterile shoe covers (food grade products only)



WARNING: For personal protection while operating and adjusting the UHDD™, contain long hair, do not wear loose jewelry, and wear ear protectors.

Instructions

Note: Wear latex/rubber gloves (and appropriate food grade attire if applicable) during this process.

1. Plug in the machine and turn it on.
2. Adjust the voltage by pressing the Vol+ and Vol- buttons.



Maintenance

To ensure that the UHDD™ will have a long operational life, maintenance is essential. This section includes methods for troubleshooting solutions and how often to clean your machine to keep its performance optimal.

General Maintenance Prescriptions

- Use the maintenance checklist (found in the Appendix) before, during, and after machine operation.
- Unplug the machine before cleaning.
- Before reassembling the machine after cleaning, make sure that the parts are dried.
- Constantly check for any loose nuts and/or screws before, during, and after machine operation.

Repair and Replacement

Some parts of the UHDD™ may need to be removed for repair and replacement.

Warranty

To access LFA's warranty policy, go to <https://www.lfatabletpresses.com/warranty>

If your part is eligible for warranty, have your part's serial number on hand and please contact LFA:

UK

Phone

+44 01869 250234

Email

support.uk@lfamachines.com

USA

Phone

+1 (682) 312-0309

Email

support.usa@lfamachines.com

Taiwan

Phone

+886 422031790

Email

support.asia@lfamachines.com

Troubleshooting

Sometimes unavoidable issues will occur while operating the UHDD™. Fortunately, there are several methods to remedy these issues.

Common Machine/Part Issues

Symptom	Possible Cause	Possible Solution
Machine does not vibrate after being turned on	The power plug is loose from outlet or from the machine.	Re-connect the power plug to the machine and the outlet.
Tablets are not being passed through the sifter	There is damage to the sifter.	Check the sifter for any abnormalities/damage and change if needed.
	The machine is not on even ground.	Level the machine so that it is on even ground.
Abnormal noise is coming from the machine	There are loose parts or loose nuts and bolts.	Check all parts in the machine and tighten any loose nuts and bolts.
Electromagnet is not working	The electromagnet spring is disconnected, loose, etc.	Check the spring and reconnect it/replace it if damaged.
	The connection between the electromagnet and armature is too weak.	Make adjustments so that the electromagnet charge is able to move the armature again.
Tablets are dropping into the powder collection plate	The sifter is moving abnormally during operation.	Check and tighten/adjust.
	The Feeder or Discharge Chute are loose and tablets are escaping from them.	

De-Jamming the UHDD™

Sometimes tablets may get jammed in the machine's sifter.

Tools and Materials Needed

- Level
- Disposable latex/rubber gloves (for food grade products and to protect hands from grease)
- Hairnet and/or beard net (food grade products only)
- Sterile shoe covers (food grade products only)



WARNING: To prevent any potential personal injury, ALWAYS unplug the UHDD™ before de-jamming it.

Instructions

Note: Wear latex/rubber gloves (and appropriate food grade attire if applicable) during this process.

Check the Machine's Sifter

1. Loosen the four knobs on the machine by hand.

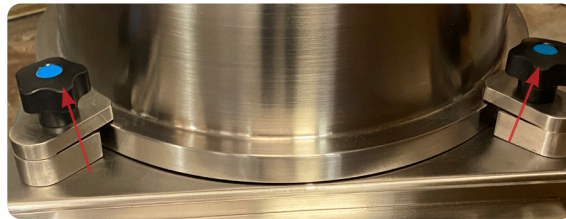

2. Remove the machine's outer cover's outer ring by loosening it by hand.



4. Raise the outer cover carefully over the sifter.
5. Inspect the machine sifter for any damage in the welding or the sifter itself. If needed, loosen the lock on top of the locating rod and remove the two pieces of the sifter by slightly twisting the two from each other.

5.1 Note: If damaged, the UHDD™ may be eligible for warranty. Please see LFA's warranty policy at <https://www.lfatabletpresses.com/warranty>.

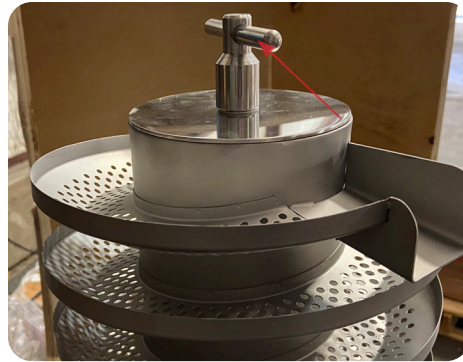

Level and Balance the Machine

1. Use a level to ensure that the UHDD™ is balanced on the floor.
 - 1.1 Note: If it is not level, move the machine to a flat surface. Use the machine's wheels to help find an appropriate and balanced floor.



Cleaning

During the UHDD™'s operation, excess powder will find its way into parts of the machine. It is important to clean the UHDD™ thoroughly to prevent rusting and cross contamination.

LFA recommends that the machine be cleaned after each operation.

Tools and Materials Needed

- Cleaning brush
- Toothbrush
- Disposable latex/rubber gloves
- Bagless vacuum
- Clean cloths
- Potable water
- Sanitizer (e.g. Member's Mark Commercial Sanitizer)
- Hairnet and/or beard net (food grade products only)
- Safety goggles
- Sterile shoe covers (food grade products only)



WARNING: To prevent any potential personal injury, ALWAYS unplug the UHDD™ from the electrical outlet when replacing parts.

Instructions

Note: Wear safety goggles and latex/rubber gloves (and appropriate food grade attire if applicable) during this process.

Remove the Machine Parts

1. Loosen the outer cover's lock by hand and remove it.



2. Raise the outer cover over the machine sifter.

3. Loosen the lock on top of the locating rod and remove the two pieces of the sifter by slightly twisting the two from each other.



Clean the Machine Parts

4. Vacuum the bottom of the machine and around the locating rod.

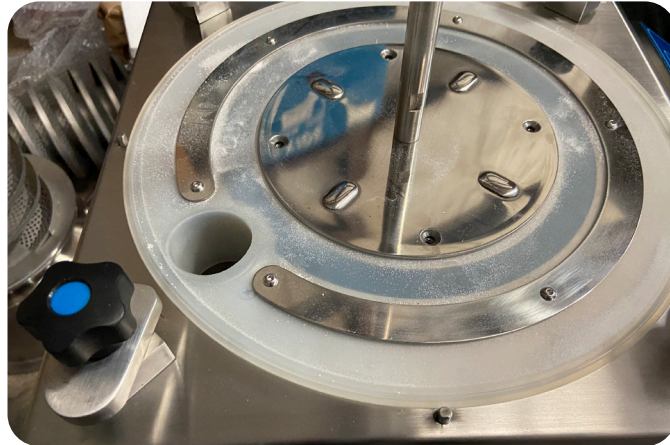

5. Use the sanitizer on all non-metal parts/surfaces on the machine and machine parts.

6. Use potable water to clean the sanitizer.

6.1 Note: Do NOT use alcohol to clean the non-metal parts of the machine.

7. Insert the two pieces of the sifter back over the locating rod.

8. Resecure the lock on top of the locating rod by hand.

9. Place the outer cover over the machine sifter.

10. Lock the outer cover by hand.

Cleaning Schedule Matrix

Part	Frequency							
	After installing machine	After every use	Before every use	In between products that present a cross contamination risk	Weekly	Monthly	Before placing in storage	After removing from storage
Outer Cover Window	Remove from machine	Clean on machine	Clean on machine	Remove from machine	Clean on machine	Clean on machine	Clean on machine	Remove from machine
Machine Body (outside machine)	Clean on machine	Clean on machine	Clean on machine	Clean on machine	Clean on machine	Clean on machine	Clean on machine	Clean on machine
Sifter (inside machine)	Remove from machine	Clean on machine	Clean on machine	Remove from machine	Clean on machine	Clean on machine	Clean on machine	Remove from machine
Corrugated Tube (if using)	Remove from machine	Remove from machine	Clean on machine	Remove from machine	Clean on machine	Clean on machine	Remove from machine	Install on machine
Feeder/Discharge Chute	Clean on machine	Clean on machine	Clean on machine	Clean on machine	Clean on machine	Clean on machine	Clean on machine	Clean on machine

Cleaning Level Key	
Level 1 - Remove powder	
Level 2 - Dry clean with cloth	
Level 3 - Dry clean and re-lubricate if specified in lubrication schedule	
Level 4 - Wet clean and re-lubricate if specified in lubrication schedule	
Remove from machine - Take part out of machine and clean if required. Store it correctly or install back into machine.	
Install into machine - Install part into the machine and make sure that it has been cleaned. If needed, lubricate to the level required.	
Clean on/in machine - Clean the part while in the machine and do not remove it. Make sure that all contact surfaces are clean to the level required.	

This cleaning matrix is intended as a guide only and is not an exhaustive list. All cleaning schedules will need to be adapted to the industry and product, following industry regulations and the material safety data sheets that come with specific products. Please check with your Food Safety Manager/Department, Quality Control Manager/Department, or other relevant internal departments at your company before using.

Storing the UHDD™

After its thorough cleaning, the UHDD™ needs to be stored in the proper conditions. It is important to store it in an environment in which the machine is safe from rusting.

Tools and Materials Needed

- Plastic wrapping to cover machine
- Disposable latex/rubber gloves (for food grade products and to protect hands from lubricant)
- Hairnet and/or beard net (food grade products only)
- Sterile shoe covers (food grade products only)

Instructions

Note: Wear latex/rubber gloves (and appropriate food grade attire if applicable) during this process.

Cover the UHDD™

1. Carefully cover the UHDD™ with the plastic wrapping.

1.1 Note: You can use the plastic wrapping that came with the machine in the shipping container.

Environmental Conditions

It is important that the environment in which you store the UHDD™ has the appropriate temperature and relative humidity levels. These two environmental factors can potentially cause the machine to rust. The table below shows the acceptable temperature and relative humidity levels:

Machine	Temperature		Humidity
UHDD™	°C	°F	45-65% RH
	15-28	59-83	

Appendix

Glossary

Term	Definition
API/Active Pharmaceutical Ingredient	Any substance or mixture of substances used that is an active ingredient in the drug product.
Binding agent	See excipient.
Excipient	An inactive substance that serves as the vehicle or medium for a drug or other API.
Formulation	Powder mix of the excipient and the API that is compressed to make tablets.
Friability	The tendency of a tablet to break into smaller pieces during contact.
Granular material	See Formulation.
UHDD™	LFA trademarked term for uphill tablet de-duster.

Description of UHDD™ Parts

Outer Cover

The Outer Cover prevents excess tablet powder from escaping the machine and into the workspace. There is also a window located on it.



Feeder

The Feeder is the point at which tablets are inserted to be de-dusted.

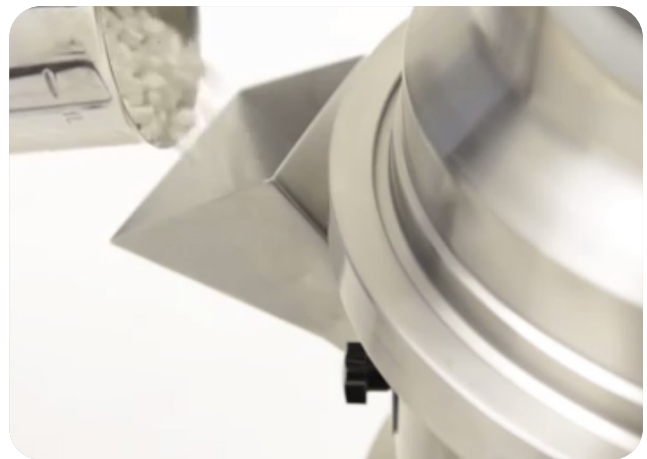

Discharge Chute

The Discharge Chute guides the de-dusted tablet away from the machine and into the desired receptacle.



Control Panel

The Control Panel includes the ON/OFF button and the dial that adjusts the operation speed.



Sifter

The Sifter carries the tablets up through the machine while removing the dust from them.

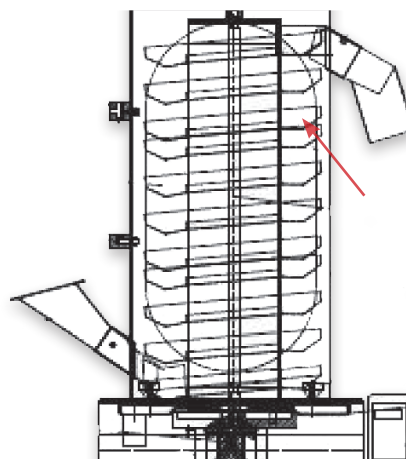

Material of Contact Parts

Contact Part	Material
Feeder	SS316
Discharge Chute	SS316
Sifter	SS316

Technical Specifications

Capacity (tablet/h)	1,000,000 (Ø8 mm)
Power (W)	150
De-dusting distance (m)	6.2
Max tablet diameter (mm)	Ø25
Power supply	110 V - 240 V (± 10%) 50 Hz/60 Hz 1 phase
Compressed air	0.1 m ³ /min–0.1 MPa
Vacuum cleaning	2.5 m ³ /min–0.1 MPa
Noise (db)	<75
Dimensions (mm)	500 x 550 x 1350-1500
Dimensions with suggested working clearance (mm)	1400 x 1450 x 2250-2400
Weight (kg)	70

Maintenance Checklist

Before Operation	
<input type="checkbox"/>	Visually inspect the de-duster and the parts.
<input type="checkbox"/>	Ensure that all wires are connected and that a proper electrical outlet is nearby (single phase 110 V - 240 V [$\pm 10\%$]).
<input type="checkbox"/>	If connected to a rotary tablet press, the UHDD™ Feeder must be near the Discharge Chute of the tablet press.
<input type="checkbox"/>	Ensure the piping and connectors are properly installed.
<input type="checkbox"/>	Ensure that the machine's wheels are locked.
<input type="checkbox"/>	Conduct a test run for the machine with a few tablets and slowly adjust the operation speed. Watch out for any abnormalities such as excess noise or vibration.
During Operation	
<input type="checkbox"/>	During a regular run, listen for irregular knocking or clicking sounds. If heard, stop operation and investigate the source of the sound.
<input type="checkbox"/>	Watch for buildup of powder in the Sifter and corrugated tube. If occurring, clear the buildup with a cleaning brush or vacuum.
<input type="checkbox"/>	If needed, adjust the clearance between the armature and the electromagnet.
<input type="checkbox"/>	Inspect the de-dusted tablets for any damage once they come out from the machine.
After Operation	
<input type="checkbox"/>	Unplug machine and remove all excess powder with a bagless vacuum.
<input type="checkbox"/>	Open the Outer Cover and clean the inside of the machine (e.g. Sifter).
<input type="checkbox"/>	Wipe down the other surfaces with a damp cloth.

UHDD™ Dimensions

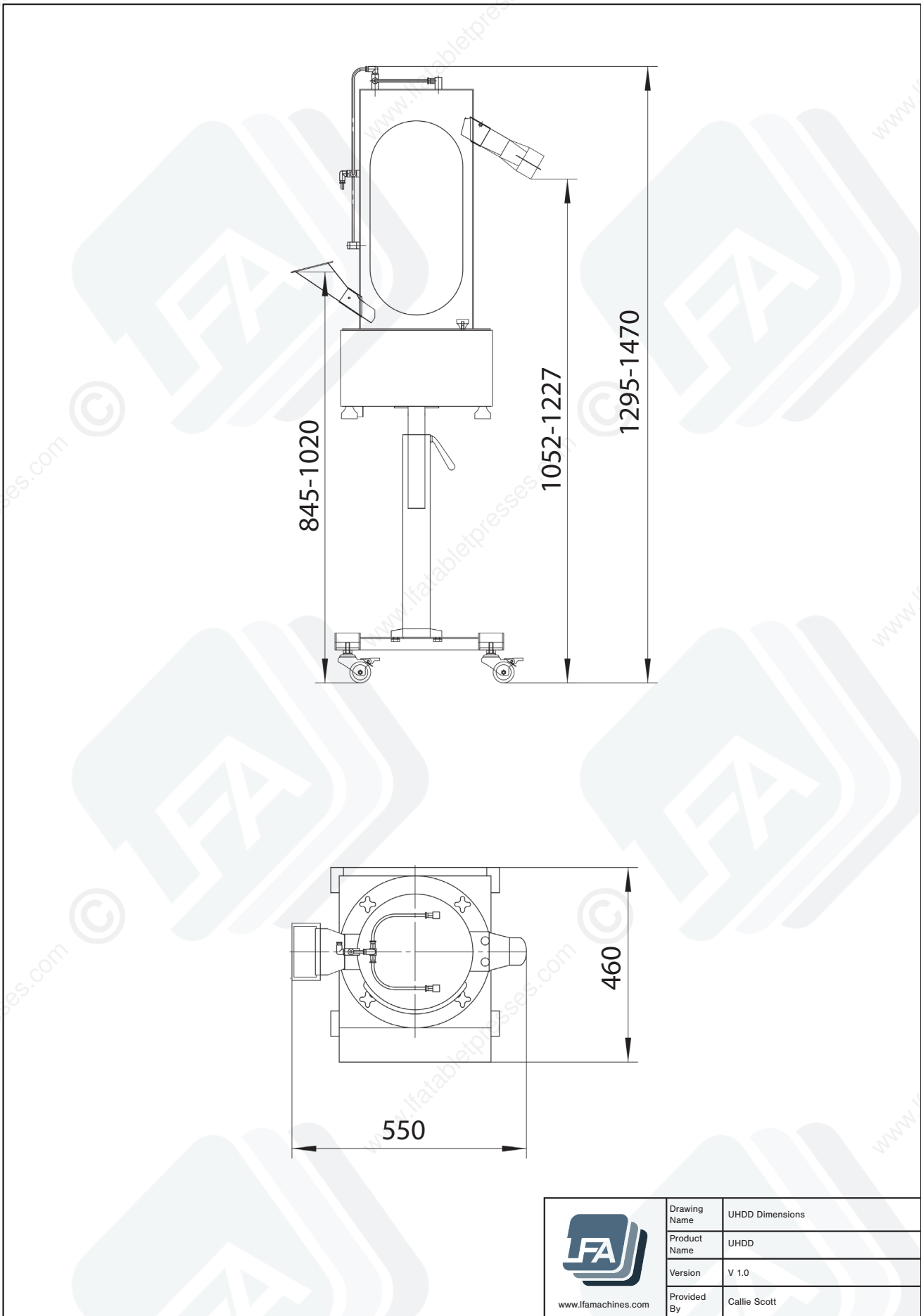

 www.lfamachines.com	Drawing Name	UHDD Dimensions
	Product Name	UHDD
	Version	V 1.0
	Provided By	Callie Scott

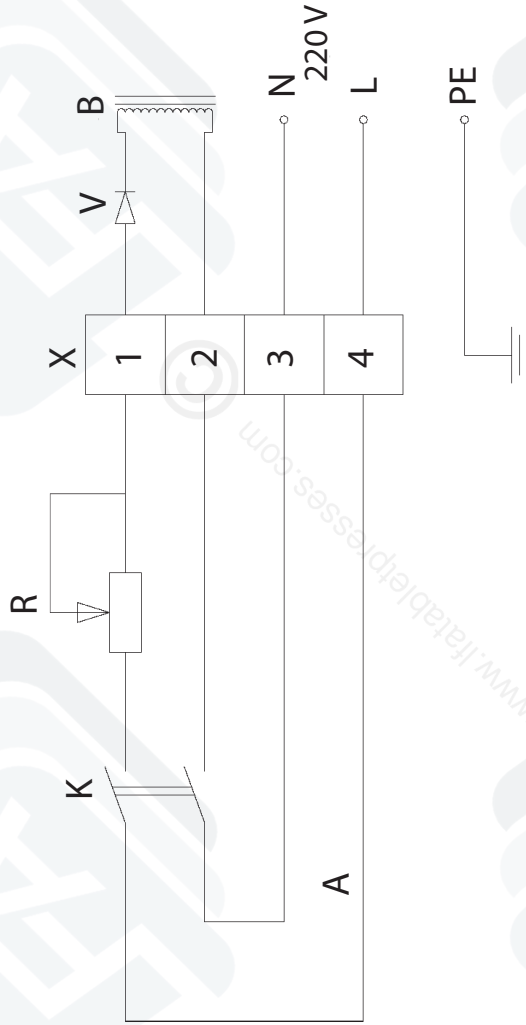

Key

- K = Switch
- R = Potentiometer
- V = Rectifier Tube
- B = Electromagnet
- X = Linker

Note: The interval between the upper side of the electromagnet and the bottom of the armature should be 1.5 mm to 2.5 mm.

 www.famachines.com	Drawing Name	UHDD Electrical Drawing
	Product Name	UHDD
	Version	V 1.0
Provided By	Calle Scott	

Resources

Helpful Links

Warranty

For information regarding the warranty policy of the UHDD™ and other LFA products, please visit <https://www.lfatabletpresses.com/warranty>

LFA Website

In order to aid you in your tablet production, LFA Machines maintains a website that offers a breadth of useful information about our machines. Use our online tools such as the Tablet Mix Calculator to help you in your formulation production or read our regularly published articles that cover a whole range of topics about tablet presses and tablet production.

Visit the LFA homepage at <https://www.lfatabletpresses.com>

LFA Machines YouTube Channel

Our YouTube videos provide you an opportunity to see how to use our tablet presses, common troubleshooting tips, and other LFA products such as capsule fillers and mixers. We regularly upload videos to give you a visual aid that will hopefully support you in your tablet production efforts. To watch our videos, visit <https://www.youtube.com/channel/UCwtbcwja77ai7vX2o34FUkQ>

LFA Machines Social Media

Social media is a great way to keep yourself updated on new developments and exciting things happening at LFA Machines. The list below contains our current social media pages:

Twitter: @lfatabletpress

Instagram: @lfatabletpresses

Facebook: <https://www.facebook.com/lfatabletpresses>

LinkedIn: <https://www.linkedin.com/company/lfa-machines-oxford-ltd/>

Contact Us

UK

LFA Machines Oxford Ltd
Unit 4B Rowood Estate
Murdock Road
Bicester, Oxfordshire OX26 4PP
+44 01869 250234
support.uk@lfamachines.com
Monday-Friday
9AM-5PM GMT

USA

LFA Machines DFW, LLC
6601 Will Rogers Blvd
Fort Worth, TX 76140
+1 (682) 312 0034
support.usa@lfamachines.com
Monday-Friday
8AM-6PM UTC (Central)

Germany

LFA Machines Düsseldorf GmbH
Business Parc Am Trippelsberg 92
Düsseldorf, North-Rhine
Westphalia 40589
+41 21188250223
verkauf@lfamachines.com

Taiwan

LFA Machines Taiwan Ltd
7F-5, No. 2, Sec. 2 Taiwan Blvd
West District, Taichung City 403
Taiwan
+886 422031790
support.asia@lfamachines.com
Monday-Friday
9AM-5PM GMT+8



LFA MACHINES

Copyright © 2023 by LFA Machines

www.lfamachines.com

United Kingdom

Unit 4B
Murdock Road
Bicester
Oxfordshire
United Kingdom
OX26 4PP

United States

6601 Will Rogers Blvd
Fort Worth
Texas
United States
76140

Germany

Business Parc Am
Trippelsberg 92
Düsseldorf
Germany
40589

Taiwan

7F.-5, No. 2, Sec. 2
Taiwan Blvd., West Dist.,
Taichung City 403,
Taiwan