



# VH™ Powder Mixers User Manual



We don't just sell machines—  
we provide service.

# Copyright Notice

© LFA Machines Oxford Limited, published in 2022 by LFA Machines Oxford Limited 2022. Registered in England and Wales, company number 08428898, registered office for service Demar House 14 Church Road East Wittering, Chichester, West Sussex, PO20 8PS.

All rights reserved. No part of this publication may be reproduced or transmitted, in any form or by any means, or stored in any retrieval system of any nature, without prior permission, except for fair dealing under the Copyright, Designs and Patents Act 1988, or in accordance with the terms of license issued by the Copyright Licensing Agency in respect of photocopying and/or reprographic reproduction. Application for permission for other use of the copyright material including permission to reproduce extracts in other published works shall be made to the publisher. Full acknowledgment of author, publisher and source must be given.

All trade marks are acknowledged and are owned by their respective owners.

# Important Safety Information

## READ THIS BEFORE OPERATING MACHINE

### Intended Use

The intended use of this machine is to thoroughly blend dry raw materials.

Potential misuse of this machine includes:

- Completely filling the V-Tank with powder (over  $\frac{2}{3}$  full).
- Not properly mounting the machine.
- Using explosive powders sensitive to movement.
- Using wet or damp material.

### Personal Protection

For personal protection while transporting the VH™ Powder Mixer, abide by these actions:

- Use an engine hoist or forklift to lift the machine.
- Wear steel toe boots to prevent foot injury.
- Wear heavy duty grip gloves to ensure firm grasp on machine.
- Wear back support belt to prevent injury if needed.

For personal protection while operating the VH™ Powder Mixer, abide by these actions:

- Avoid wearing loose jewelry to prevent machine entanglement.
- Contain long hair to prevent machine entanglement.
- Wear safety goggles.
- Wear disposable latex/rubber gloves.
- Wear a hairnet (food grade products only).
- Wear a beard net if needed (food grade products only).

### General Hazards

**In the case of an emergency during operation, immediately push the Emergency Stop button.**

- Be aware of risk of entanglement and pinch point due to moving parts.
- Do not operate in a wet environment or with wet hands due to risk of electrical shock or burn.
- Do not operate if any wires are exposed in cables due to risk of electrical shock or burn.
- Keep out of reach of children.
- Keep fingers away from all moving parts.
- Ensure that it is secured to a workbench to prevent from falling.
- Inspect machine before use.
- Check that nuts and bolts are suitably tightened.
- Use this machine only for its intended use as described in this manual.
- Do not modify the machine in any way.
- Turn off and unplug the machine before conducting cleaning and maintenance.

# Important Safety Information

## READ THIS BEFORE OPERATING MACHINE

### Symbols



#### WARNING

This signals potential risk for personal injury.



#### WARNING

This signals potential risk for electrical shock.



#### CAUTION

This signals potential risk for damage to the machine or other parts.

### Modes for Stopping

In the case of an emergency during operation, immediately unplug the VH™ Powder Mixer and/or push the Emergency Stop button:



### Prop. 65 Statement for CA Residents

Based on LFA's current level of knowledge of our machines, the VH™ Powder Mixer range does not require a Proposition 65 warning label.

### Warning for Explosive Material

This machine is not explosion proof. LFA recommends that you test your materials' explosivity before running them through this machine. If your materials are indeed explosive, do not use them with this machine.

# Important Safety Information

## READ THIS BEFORE OPERATING MACHINE

### Safety Assessment (VH 8™ and VH 14™)

It is critical to conduct a safety assessment to ensure that it complies with all local laws and industry accepted safety regulations.

If you require guidance on the installation of the machine or conducting a safety assessment, please contact LFA Machines.

### Installation and Safety Assessment (VH 100™–VH 500™)

Due to the nature and design of this machine and its intended use in an industrial environment, it is important that before use it is installed in a cage with a mode of stopping on the outside of the cage. LFA Machines has decided that we can not possibly foresee all of the environments or situations in which this machine could be used or installed and therefore have determined that the end user must install the machine in a way that is appropriate and safe for its use.

Once the machine has been installed, it is critical that you conduct a safety assessment to ensure that it complies with all local and industry accepted safety regulations.

If you require guidance on the installation of the machine or conducting a safety assessment, please contact LFA Machines.

This machine is sold as an Unfinished Machine under the Machinery Directive (2006/42 / EC) Article 13.

# Table of Contents

|  |           |
|--|-----------|
| <b>Copyright Notice</b>                              | <b>2</b>  |
| <b>Important Safety Information</b>                  | <b>3</b>  |
| Intended Use   | 3         |
| Personal Protection                                  | 3         |
| General Hazards                                      | 3         |
| <b>Important Safety Information</b>                  | <b>4</b>  |
| Symbols  | 4         |
| Modes for Stopping                                   | 4         |
| Prop. 65 Statement for CA Residents                  | 4         |
| Warning for Explosive Material                       | 4         |
| Safety Assessment (VH 8™ and VH 14™)                 | 5         |
| Installation and Safety Assessment (VH 100™–VH 500™) | 5         |
| <b>VH™ Powder Mixer Components</b>                   | <b>7</b>  |
| <b>VH™ Powder Mixer Electrical Components</b>        | <b>8</b>  |
| <b>Preface</b>                                       | <b>9</b>  |
| <b>Training</b>                                      | <b>10</b> |
| Off-Site Training                                    | 10        |
| Training via Video Chat/Phone                        | 10        |
| LFA Articles   | 10        |
| LFA Videos   | 10        |
| <b>Installation</b>                                  | <b>11</b> |
| Tools and Materials Needed                           | 11        |
| The Appropriate Workstation for the Machine          | 11        |
| Positioning the VH™ Powder Mixer                     | 13        |
| Controls   | 14        |
| Settings and Adjustment                              | 19        |
| <b>Maintenance</b>                                   | <b>20</b> |
| General Maintenance Prescriptions                    | 20        |
| Lubrication  | 20        |
| Dismantling for Repair and Replacement               | 23        |
| Wear Parts and Causes of Damage                      | 24        |
| <b>Troubleshooting</b>                               | <b>33</b> |
| Common Machine Issues                                | 33        |
| De-Jamming the VH™ Powder Mixer                      | 34        |
| Cleaning   | 35        |
| Storing the VH™ Powder Mixer                         | 38        |
| <b>Appendix</b>                                      | <b>39</b> |
| Glossary   | 39        |
| Description of VH™ Powder Mixer Parts                | 40        |
| Food Grade Point of Contact Parts                    | 41        |
| Technical Specifications                             | 41        |
| Maintenance Checklist                                | 42        |
| Diagrams   | 43        |
| Resources  | 53        |

# VH™ Powder Mixer Components

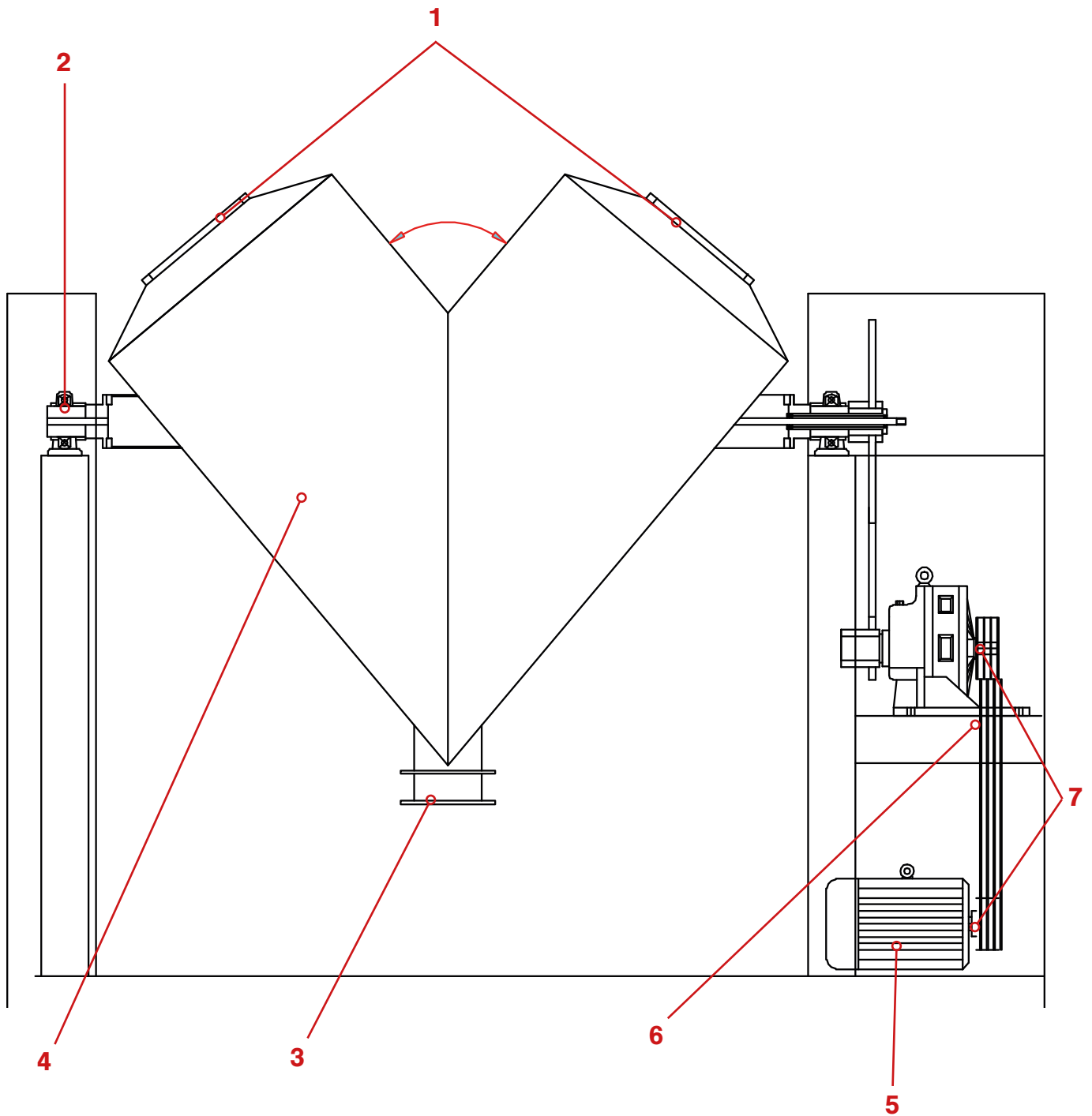

- 1. Feeder Points
- 2. Bearings
- 3. Discharge Chute
- 4. V-Tank

- 5. Motor
- 6. V Belt
- 7. Drive Belt Pulleys

# VH™ Powder Mixer Electrical Components



- 1. Start machine operation
- 2. Stop machine operation
- 3. Jog machine

- 4. Set operation time
- 5. Emergency stop



# Preface



The VH™ Powder Mixers are machines that blend dry powder and granular materials. The VH™ series includes seven mixers that have a range of 8 liters to 500 liters maximum capacity. All of the VH™ Powder Mixers share the same design principle of asymmetric mixing tubes that are agitated and rotated to ensure highly efficient mixing. The VH™ Powder Mixers are suitable for the pharmaceutical, chemical, and food industries, ceramics, metallurgy, and any application that requires the thorough combining of two or more dry powders or granules.

The purpose of this document is to support your understanding of the VH™ Powder Mixer range's components, features, functions, and design. With this manual, you will be able to successfully operate and maintain your VH™ Powder Mixer machine.

The user manual's content includes:

- Important safety information
- VH™ Powder Mixer installation instructions
- Description of the VH™ Powder Mixer operation
- VH™ Powder Mixer maintenance information
- Appendix with supplemental information

# Training

VH™ Powder Mixer training is essential for the machine's successful operation and your personal safety. There are several methods to prepare you for working with the VH™ Powder Mixer.

## Off-Site Training

LFA offers free training at our UK, USA, and Taiwan facilities for all our customers and their teams. For more information, go to <https://www.lfatabletpresses.com/services>

## Training via Video Chat/Phone

Using an online video chat system, an LFA technician can interact face-to-face with you and assist with your understanding of the machine. Or, if you prefer, LFA can provide training via phone for all customers who call the office. To set up a training, call or email your local LFA office:

### UK

#### Phone

+44 01869 250234

#### Email

[support.uk@lfamachines.com](mailto:support.uk@lfamachines.com)

### USA

#### Phone

+1 (682) 312-0034

#### Email

[support.usa@lfamachines.com](mailto:support.usa@lfamachines.com)

### Taiwan

#### Phone

+886 422031790

#### Email

[support.asia@lfamachines.com](mailto:support.asia@lfamachines.com)

## LFA Articles

LFA writes informative articles about our machines, which includes instructions, procedures, and guides. To access the articles, go to <https://www.lfatabletpresses.com/articles> or <https://www.lfacapsulefillers.com/articles>

## LFA Videos

LFA has created several videos involving the VH™ Powder Mixer and other machines. To access the videos, go to <https://www.lfatabletpresses.com/videos> or <https://www.youtube.com/user/TabletPilPress>

# Installation

## Tools and Materials Needed

Before you install and operate the VH™ Powder Mixer, it is best to have the following tools and materials on hand for general operation and maintenance:

- Engine hoist/forklift
- Lifting strap
- Level
- Hammer
- Crowbar
- Rubber mallet
- Metric wrench set
- Scissors/box cutter
- Container to catch mixed powder from machine
- Flathead screwdriver
- Set of metric Allen keys with ball ends
- Cleaner (e.g. Member's Mark Commercial Lemon Disinfectant)
- Sanitizer (e.g. Member's Mark Commercial Sanitizer)
- Lubricant (NSF approved type for food grade products)
- Toothbrush
- Cleaning brush set
- Plastic sheet or something similar to cover machine
- Safety goggles
- Hairnet and/or beard net (food grade products only)
- Sterile shoe covers (food grade products only)

## The Appropriate Workstation for the Machine

The floor on which the machine is to be placed must support the VH™ Powder Mixer's weight.

| Machine Weight and Floor Loading (Static) |                   |                         |
|---|-------------------|-------------------------|
| VH 8™                                     | 44 kg (97 lbs)    | 0.129 kN/m <sup>2</sup> |
| VH 14™                                    | 60 kg (132 lbs)   | 0.198 kN/m <sup>2</sup> |
| VH 100™                                   | 200 kg (440 lbs)  | 2.98 kN/m <sup>2</sup>  |
| VH 150™                                   | 250 kg (551 lbs)  | 3.73 kN/m <sup>2</sup>  |
| VH 200™                                   | 300 kg (661 lbs)  | 6.71 kN/m <sup>2</sup>  |
| VH 300™                                   | 350 kg (771 lbs)  | 4.68 kN/m <sup>2</sup>  |
| VH 500™                                   | 550 kg (1212 lbs) | 11.28 kN/m <sup>2</sup> |

The VH 8™ and VH 14™ motors requires a single-phase power supply of 240 V or 110 V, and the VH 100™, VH 150™, VH 200™, VH 300™, and VH 500™ motors require a three-phase power supply of 440 V or 220 V ( $\pm 10\%$ ). Ensure to position the machine near an appropriate electrical plug.

## Environmental Conditions

It is important that the environment in which you operate and store the VH™ Powder Mixer has the appropriate temperature and relative humidity levels. These two environmental factors can potentially cause the machine to rust and/or cause low quality in powder mixtures.

| Appropriate Environmental Conditions |             |       |           |
|--------------------------------------|-------------|-------|-----------|
| Machine                              | Temperature |       | Humidity  |
| VH™ Powder Mixer Range               | °C          | °F    | 45-65% RH |
|                                      | 18-24       | 64-75 |           |

## Unpacking the VH™ Powder Mixer

### Tools Needed

- Crowbar
- Hammer (for VH 8™ and VH 14™)
- Scissors/box cutter (for VH 100™ up to VH 500™)

### Instructions

1. Pry open the shipping container with a crowbar.
2. Remove the machine from the shipping container's base.
  - 2.1 Note: The VH 8™ and VH 14™ are secured to the shipping container with a 1x1 support. Use a hammer to remove this support. The VH 100™ up to VH 500™ are strapped to the base. Cut the straps with scissors or a box cutter to remove the machine from the shipping container.
  - 2.2 Note: Keep the nuts, bolts, and the shipping container's base in case you need to move or relocate the VH™ Powder Mixer.

## READ BEFORE INSTALLATION:

Depending on local health and safety laws, the VH™ Powder Mixer may be required to be installed in a cage. A risk assessment is required to be conducted before installation and operation of the machine.

LFA Machines is able to advise on this. Please contact us for more information:

### UK

#### Phone

+44 01869 250234

#### Email

[support.uk@lfamachines.com](mailto:support.uk@lfamachines.com)

### USA

#### Phone

+1 (682) 312-0034

#### Email

[support.usa@lfamachines.com](mailto:support.usa@lfamachines.com)

### Taiwan

#### Phone

+886 422031790

#### Email

[support.asia@lfamachines.com](mailto:support.asia@lfamachines.com)

## Positioning the VH™ Powder Mixer



**WARNING:** To prevent personal injury, wear steel toe boots and heavy duty grip gloves while transporting the VH™ Powder Mixer.

LFA does NOT recommend carrying the machine manually but rather with a forklift or engine hoist. At least two people should be involved (one operating the forklift/engine hoist and one stabilizing the machine) in removing the machine from the shipping container and placing it in the workspace.

### Moving the VH™ Powder Mixer

#### Tools Needed

- Forklift/engine hoist
- Lifting strap that supports VH™ Powder Mixer's weight
- Heavy duty grip gloves
- Steel toe boots

#### Instructions

1. Wrap the lifting strap around the VH™ Powder Mixer's base and top.
2. Attach the lifting strap to the forklift/engine hoist.
3. Carefully raise the VH™ Powder Mixer and guide it to the desired location.
  - 3.1 Note: The VH 8™ and VH 14™ require a single-phase power supply of 110 V or 220 V. The VH 100™-VH 500™ range require a three-phase power supply of 220 V or 440 V ( $\pm 10\%$ ).
4. Carefully lower the VH™ Powder Mixer until it is placed in the desired location.
5. Plug in the machine to an outlet (VH 8™ and VH 14™ require further assembly).

### VH 8™ and VH 14™ Assembly

#### Tools Needed

- Contents inside of shipping container (V-Tank and machine base with motor)
- Set of metric Allen keys with ball ends

#### Instructions

1. Unwrap the V-Tank from its plastic wrapping.
2. Place the V-Tank on the insert of the main machine base.
3. Insert the set screw and tighten it with an Allen key.
4. Plug in the machine to an outlet.



# Controls

## Basic Components

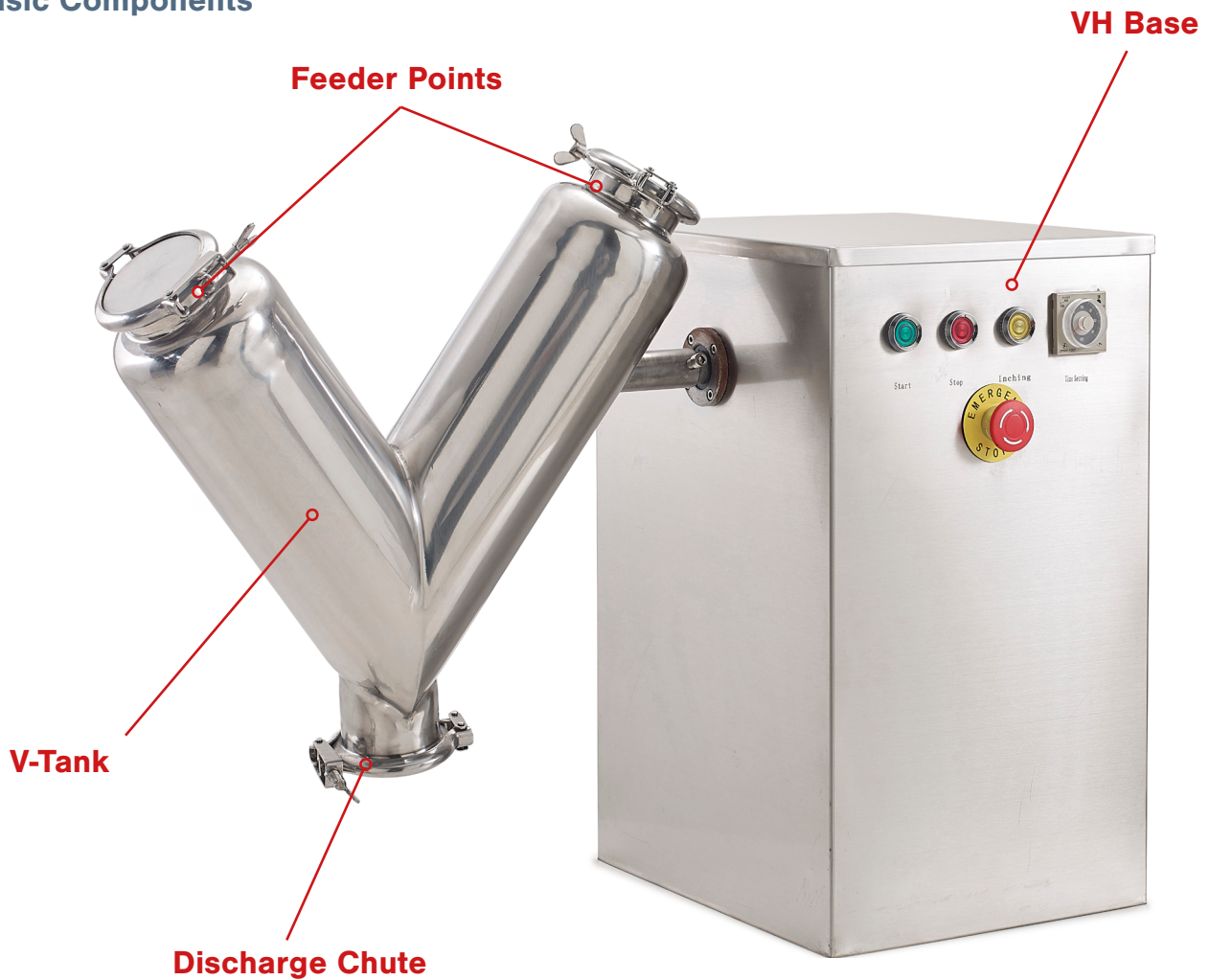

A description of the principal components follows:

- The **Feeder Points** are where the dry materials to be mixed are poured.
- The **V-Tank** contains the powder that is mixed.
- The **Discharge Chute** allows the mixed powder to be expelled from the V-Tank.
- The **VH Base** has a control console and also contains the Motor, V Belt, and Drive Belt Pulleys.

## Control Console



### VH 8™ and VH 14™ Powder Mixer

The VH 8™ and VH 14™ comes with a Start button, a Stop button, an Inching button, a Time Setting, and an Emergency Stop button.

### VH 150™-VH 500™ Powder Mixers

The VH 150™ up to VH 500™ machines possess a Start button, a Stop button, an Inching button, a Time Setting, and an Emergency Stop button.



## VH™ Powder Mixer Process

The basic mechanism of the VH™ Powder Mixer involves filling one of the Feeder Points, selecting a running time, and turning on the machine.

### Filling the V-Tank with Powder

The V-Tank is filled with powder (up to  $\frac{2}{3}$  full) through one of the Feeder Point's inlets.

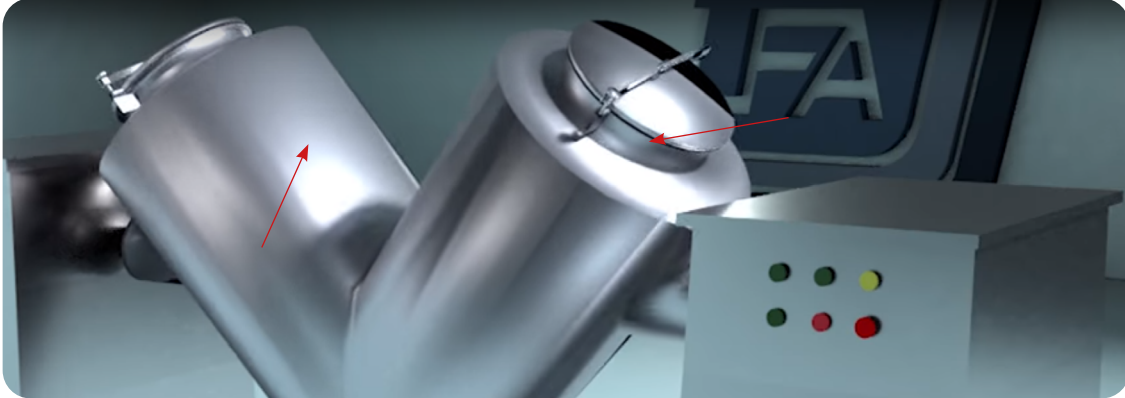

### Rotating the V-Tank to Mix the Powder

After the V-Tank is filled with powder, the machine is set to run a certain amount of time. Once the machine is turned on, the V-Tank rotates so that the powder can be thoroughly mixed.

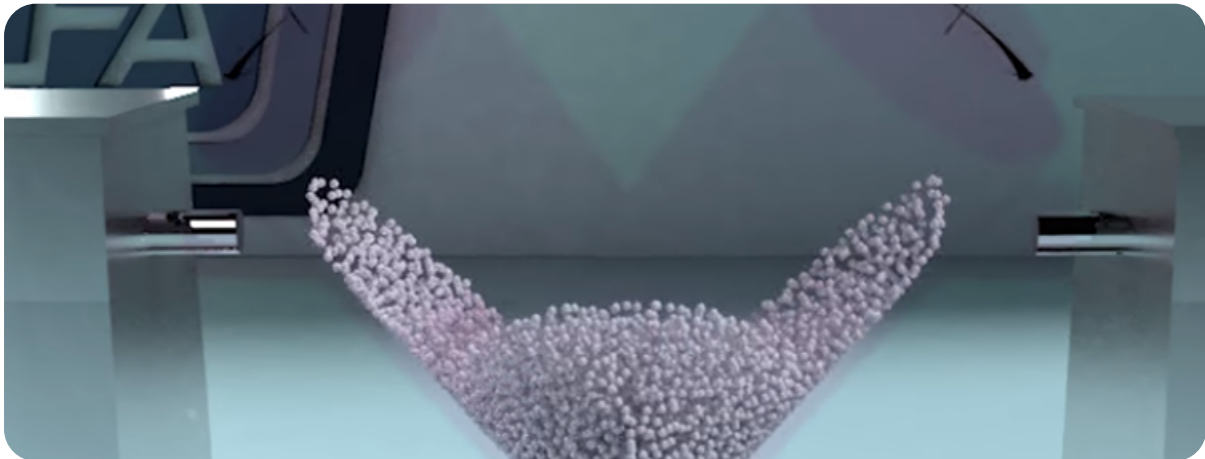

### Releasing the Mixed Powder

Once the machine has stopped operating and is in the upright position, the mixed powder can be released from the Discharge Chute into a container.

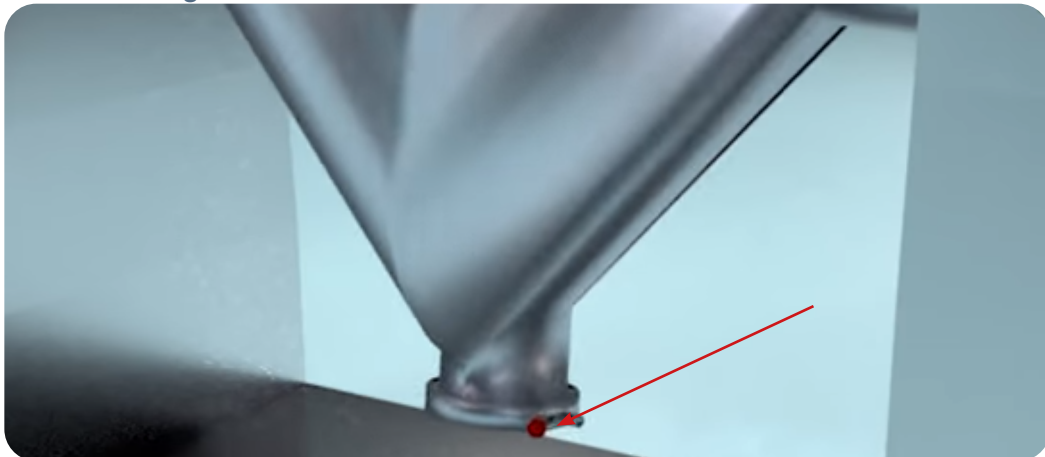



## Fill Volumes

All machines in the VH™ Powder Mixer range work on fill volume, rather than maximum weight capacity of the V-Tank, because the weight of a powder mix can vary depending on its bulk density.

The maximum fill volume represents only a percentage of the total volume of the V-Tank and is dependent on the bulk density of the powder product.

## Calculating Bulk Density

### Tools and Materials Needed

- Raw material formulation
- Measuring apparatus (e.g. 1 liter cylinder)
- Scale

### Instructions

Note: Wear latex/rubber gloves (and appropriate food grade attire if applicable) during this process.

1. Place the measuring apparatus onto the scale.
  - 1.1 Note: Ensure that the scale displays zero.
2. Fill the measuring apparatus with powder to the top.
  - 2.1 Note: Ensure not to tap down or disturb the powder while it is being poured.
3. Record the weight of the powder in mL.
4. Divide the weight of the powder by the volume of the measuring apparatus in mL.

## Resources for Calculating Bulk Density

To help with calculating bulk density of a powder, LFA offers two resources on our website.

To watch a video on how to calculate the loose bulk density of a powder, go to <https://www.lfatabletpresses.com/videos/calculating-bulk-density-making-a-tablet-pill-mix>

To see further information on bulk density and use our bulk density calculator, go to <https://www.lfatabletpresses.com/bulk-density-calculator>

## How to Mix Powder with the VH™ Powder Mixer

### Tools and Materials Needed

- Raw material formulation
- VH™ Powder Mixer
- Container for mixed powder
- Safety goggles
- Disposable latex/rubber gloves (for food grade products and to protect hands from grease)
- Hairnet and/or beard net (food grade products only)
- Sterile shoe covers (food grade products only)



**WARNING:** For personal protection while operating the VH™ Powder Mixer, contain long hair and do not wear loose jewelry

### Instructions

Note: Wear latex/rubber gloves (and appropriate food grade attire if applicable) during this process.

1. Remove one of the V-Tank's feeder point locks by unscrewing its thumb screw and take off the feeder point's lid.
2. Pour in the powder material until the V-Tank is  $\frac{2}{3}$  full and re-secure the feeder point lock.
3. Place a container underneath the V-Tank's discharge chute.
4. Press the START (green) button to begin operation.
  - 4.1 Note: Some VH™ Powder Mixers come with a time setting, which can be used to set a determined amount of time for the V-Tank to operate.
  - 4.2 Note: Some VH™ Powder Mixers come with an Inching button (yellow) that slowly jogs the machine when pushed. The Inching button can be used to position the V-Tank in the starting upright position.



5. Press the STOP (red) button to end operation (if there was no Time Setting).
6. Open the discharge chute to release the mixed powder into the container.



## Settings and Adjustment

Some VH™ Powder Mixers settings can be adjusted. Changing the machine's settings can help with changing the powder's characteristics.

### Operation Time

Some VH™ Powder Mixers have a time setting that will allow the V-Tank to rotate for a determined amount of time.

The operation time should be calculated by mix validation, which is establishing that a specific process or equipment will consistently produce a product or result. To watch a video on how to perform a mix validation, go to <https://www.lfatabletpresses.com/videos/mix-validation-making-a-tablet-mix>

### Tools and Materials Needed

- Disposable latex/rubber gloves (for food grade products and to protect hands from grease)
- Hairnet and/or beard net (food grade products only)
- Sterile shoe covers (food grade products only)



**WARNING:** For personal protection while operating the VH™ Powder Mixer, contain long hair and do not wear loose jewelry

### Instructions

Note: Wear latex/rubber gloves (and appropriate food grade attire if applicable) during this process.

1. Open the time setting's case.

1.1 Note: Not all VH™ Powder Mixers have a case covering the time setting buttons.

2. Press the buttons to make adjustments to the time settings.



2.1. Note: The two leftmost buttons are for the amount of time. The middle button switches between units of time (S = seconds, M = minutes, H = hours). For more information please refer to <https://panda-bg.com/datasheet/2231-401982-Digital-Time-Relay.pdf>

# Maintenance

To ensure that the VH™ Powder Mixer will have a long operational life, maintenance is essential. This section includes methods for replacing parts, troubleshooting solutions, and how often to grease and clean your machines to keep its performance optimal.

## General Maintenance Prescriptions

- Use the maintenance checklist (found in the Appendix) before, during, and after machine operation.
- Make sure all grease points are maintained and regularly lubricated.
- Use an appropriate amount of lubricant.
- Before reassembling the machine after cleaning, make sure that the parts are dried and oiled.
- Constantly check for any loose nuts and/or screws before, during, and after machine operation.
- If the machine is not used for more than a week, cover it with a plastic sheet.

## Lubrication

Regularly greasing your machine is vital to prolonging its operational life. Parts that are not greased properly can make the machine seize up and cause major problems later. LFA recommends maintaining a lubrication schedule for your VH™ Powder Mixer, which can be found in this section.

### Tools and Materials Needed

- NLGI Grade 2
- 460 Grade Worm Gear Oil
- Chain Lubricant - NSF H1
- Disposable latex/rubber gloves (for food grade products and to protect hands from grease)
- Hairnet and/or beard net (food grade products only)
- Sterile shoe covers (food grade products only)



**WARNING:** To prevent any potential personal injury, unplug the VH™ Powder Mixer from the electrical outlet.

### Instructions

Note: Wear latex/rubber gloves (and appropriate food grade attire if applicable) during this process.

1. Apply NLGI Grade 2 grease to the bearings on the V-Tank.
  - 1.1 Note: The VH 100™ up to the VH 500™ have grease nipples to apply the grease through.



2. Inspect the Gearbox's oil window on its side and see if the oil is below the minimum line. If it is, top it up with 460 Grade Worm Oil.





3. Apply NSF H1 chain lubricant to the drive chain (from VH 100™ up to VH 500™).



## Lubrication Schedule

LFA recommends the following VH™ Powder Mixer parts to be lubricated according to the following frequency:

| Part                                  | Location  | Image  | Frequency   | Type of Lubricant        |
|---------------------------------------|---|--|---|--------------------------|
| Bearings on V-Tank                    | Bearings that connect the V-Tank to the VH™ Powder Mixer's base   |  | Apply grease in the following situations: 1) After every 100 hours of use, 2) after a deep clean, or 3) if returning to use the machine after a prolonged period of time. | NLGI Grade 2             |
| Gearbox                               | Inside the VH™ Powder Mixer's base and above the Motor.   |  | Check the oil inspection window every month and top up if required.   | 460 Grade Worm Gear Oil  |
| Drive Chain (from VH 100™ to VH 500™) | Situated on the toothed gears attached to the Gearbox and the Motor inside the VH™ Powder Mixer's base. |  | Visually inspect the chain every week by applying a dry cloth and checking for oil patches. If the chain is dry, apply a coating of chain lubrication.                    | Chain Lubricant - NSF H1 |

# Dismantling for Repair and Replacement

Eventually due to wear and tear, some parts of the VH™ Powder Mixer will need to be removed for repair and replacement. To prevent any delays in your production, it is best practice to keep extra parts just in case.

## Warranty

To access LFA's warranty policy, go to <https://www.lfatabletpresses.com/warranty>

If your part is eligible for warranty, have your part's serial number on hand and please contact LFA:

### UK

#### Phone

+44 01869 250234

#### Email

[support.uk@lfamachines.com](mailto:support.uk@lfamachines.com)

### USA

#### Phone

+1 (682) 312-0034

#### Email

[support.usa@lfamachines.com](mailto:support.usa@lfamachines.com)

### Taiwan

#### Phone

+886 422031790

#### Email

[support.asia@lfamachines.com](mailto:support.asia@lfamachines.com)

For distributor contact information, go to

<https://www.lfamachines.com/contact>



**WARNING:** To prevent any potential personal injury, ALWAYS unplug the VH™ Powder Mixer from the electrical outlet when replacing parts.

## Wear Parts and Causes of Damage

| Wear Part | Cause of Damage  |
|-----------|--|
| V Belt    | The V Belt for the VH™ Powder Mixer range drives all of the power from the motor to the mixing barrel via the Gearbox. Overtime, this will lose some of its tension and wear, causing the belt to slip, which affects the mixer's ability to handle the maximum weight capacity. |
| Bearings  | Each of the VH™ Powder Mixers will have one or two bearings (depending on the size) to support the mixing barrel. If powder builds up around the bearings, or if they are not cleaned and/or lubricated properly, they can wear overtime.  |



## V-Tank

The V-Tank is an asymmetric mixing tube that holds the powder to be mixed. Powder is poured into one of the top inlets, and once the machine is in operation, the V-Tank rotates and combines the dry powdered granules.

### Tools and Materials Needed

- Set of metric wrenches
- New V-Tank
- Disposable latex/rubber gloves (for food grade products and to protect hands from grease)
- Hairnet and/or beard net (food grade products only)
- Sterile shoe covers (food grade products only)



**WARNING:** To prevent any potential personal injury, ALWAYS unplug the VH™ Powder Mixer from the electrical outlet when replacing parts.

### Instructions

Note: Wear latex/rubber gloves (and appropriate food grade attire if applicable) during this process.

#### Remove the V-Tank

1. Ensure that the V-Tank is in an upwards position and stabilized.
2. Remove the four bolts on each side of the V-Tank (a total of eight bolts).

2.1 Note: Ensure that the V-Tank is stabilized and does not fall.



#### Replace the V-Tank

3. Position the new V-Tank in the appropriate, upward position.

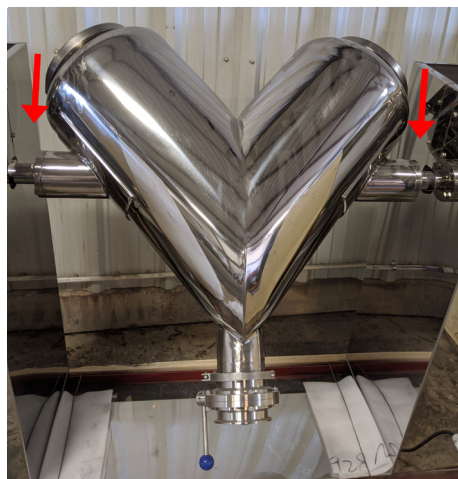

4. Tighten the four bolts on each side of the V-Tank with a wrench.  
4.1 Note: Ensure that the V-Tank is stabilized and does not fall.

## Input Gaskets

The Input Gaskets are located on top of both sides of the V-Tank. The inlet covers and locking rings must be removed in order to access the Input Gaskets.

### Tools and Materials Needed

- New Input Gaskets
- Disposable latex/rubber gloves (for food grade products and to protect hands from grease)
- Hairnet and/or beard net (food grade products only)
- Sterile shoe covers (food grade products only)



**WARNING:** To prevent any potential personal injury, ALWAYS unplug the VH™ Powder Mixer from the electrical outlet when replacing parts.

### Instructions

Note: Wear latex/rubber gloves (and appropriate food grade attire if applicable) during this process.

#### Remove the Input Gaskets

1. Remove the locking rings from both inlets located on top of the V-Tank.

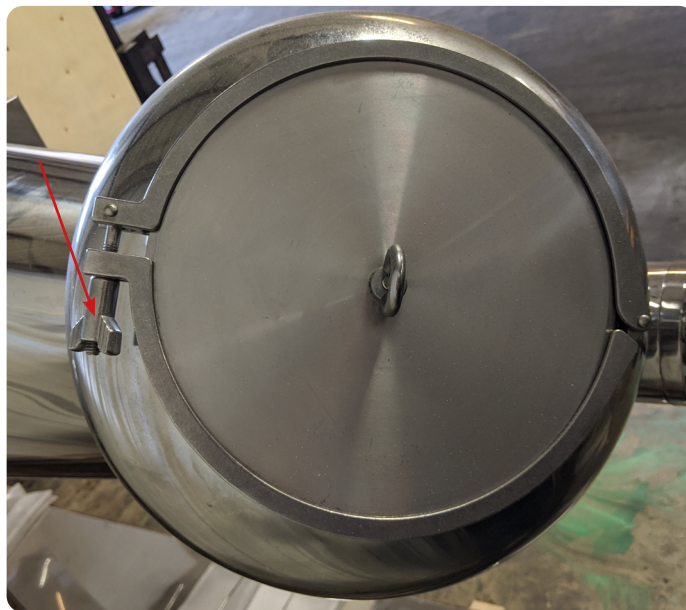

2. Remove the Input Gaskets from the top of the V-Tank's inlets.

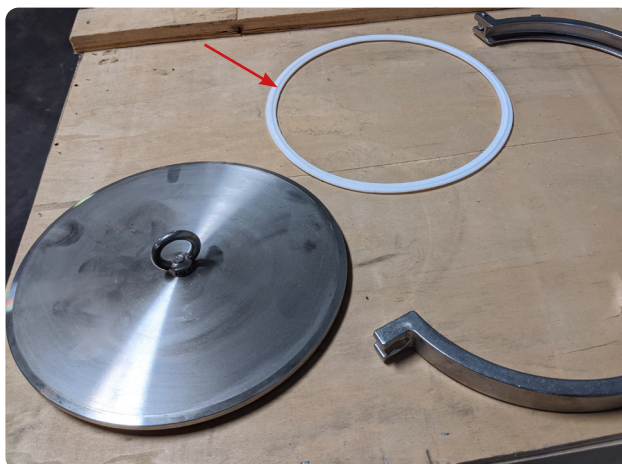

### Replace the Input Gaskets

3. Insert the new Input Gaskets into the V-Tank inlets.



4. Reinsert the V-Tank inlet covers and fasten the locking rings.

## Output Gasket

The Output Gasket is located in the discharge chute's opening. To access it, the locking ring must be loosened and the dispenser latch must be removed.

### Tools and Materials Needed

- New Output Gasket
- Disposable latex/rubber gloves (for food grade products and to protect hands from grease)
- Hairnet and/or beard net (food grade products only)
- Sterile shoe covers (food grade products only)



**WARNING:** To prevent any potential personal injury, ALWAYS unplug the VH™ Powder Mixer from the electrical outlet when replacing parts.

### Instructions

Note: Wear latex/rubber gloves (and appropriate food grade attire if applicable) during this process.

#### Remove the Output Gasket

1. Slightly tilt the V-Tank until it is at a position in which the discharge chute can be comfortably accessed.



2. Carefully remove the locking ring.

2.1 Note: Ensure that the dispenser latch is secure and does not fall.



3. Remove the dispenser latch and Output Gasket.



### Replace the Output Gasket

4. Insert the new Output Gasket onto the dispenser latch.



5. Reinsert the dispenser latch onto the bottom of the V-Tank and tighten the locking ring.

## Timer

The Timer on the VH™ Powder Mixer can be removed and replaced. To do this, the Timer's plastic covering and wires must be disconnected from the machine.

### Tools and Materials Needed

- Crosshead screwdriver
- Set of metric wrenches/adjustable wrench
- New Timer
- Disposable latex/rubber gloves (for food grade products and to protect hands from grease)
- Hairnet and/or beard net (food grade products only)
- Sterile shoe covers (food grade products only)



**WARNING:** If you do not have sufficient experience in wiring electrical items, do NOT attempt to replace this part at the risk of electrical shock.  
**Turn off and unplug the machine before replacing this part.**

### Instructions

Note: Wear latex/rubber gloves (and appropriate food grade attire if applicable) during this process.

#### Remove the Timer

1. Remove the Timer's front plastic face by loosening the four screws with a crosshead screwdriver and holding the back nuts with a wrench.

1.1 Note: The plastic front face should come right off after removing the screws.



Note: Before removing the wires, it is recommended to take a photo or make note of the wires' placement.

2. Carefully remove the wires on the back of the Timer.
3. Remove the Timer from the machine.

#### **Replace the Timer**

4. Insert the new Timer into the machine.
5. Re-wire the new Timer.

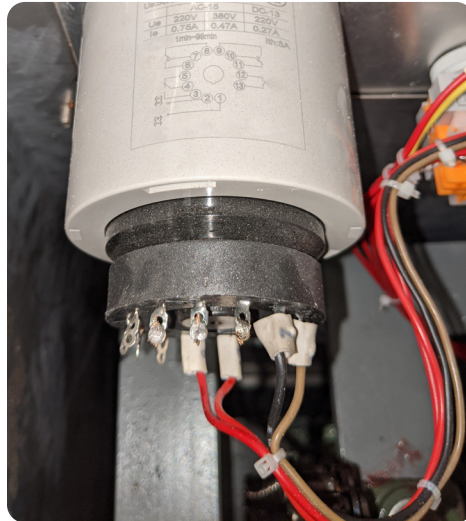

6. Place back the plastic front face and tighten its screws and nuts with a crosshead screwdriver and a wrench.



# Troubleshooting

Sometimes unavoidable issues will occur while operating the VH™ Powder Mixer. Fortunately, there are several methods to remedy these issues.

## Common Machine Issues

| Symptom                                    | Possible Cause   | Possible Solution   |
|--|--|---|
| <b>Powder takes too long to mix</b>        | The fill volume in the V-Tank is too high.   | Reduce the amount of powder in the V-Tank (does not exceed $\frac{2}{3}$ full).               |
|  | There is not enough operation time for the powder to be mixed.                         | Increase the amount of operation time on the Timer.   |
|  | The V-Tank was incorrectly filled with powder.   | Ensure to fill the V-Tank with horizontal layers of powder, rather than vertical.             |
|  | The particle properties in the powder are too different.                               | Eliminate solids/different particle sizes by granulating or milling the powder before mixing. |
| <b>Knocking sounds coming from machine</b> | The V Belt is loose.   | Tighten the V Belt.   |
|  | Parts may be loose.  | Check the machine's parts and tighten as necessary.   |
| <b>Heavy resistance during production</b>  | The high friction areas are either unclean, locked, worn out, or not greased properly. | Apply grease to all high friction areas and/or clean the machine.                             |
| <b>Excess machine vibration</b>            | The V Belt is worn.  | Replace the V Belt.   |
|  | The machine has no anti-vibration pads or they are worn.                               | Place new anti-vibration pads on the bottom of the machine.                                   |
|  | Parts may be loose.  | Check the machine's parts and tighten as necessary.   |

# De-Jamming the VH™ Powder Mixer

The method that can fix a jammed VH™ Powder Mixer can be found below:



**WARNING:** To prevent any potential personal injury, ALWAYS unplug the VH™ Powder Mixer before de-jamming it.

## Tools and Materials Needed

- Crosshead screwdriver
- Wire cutters
- Set of metric wrenches/adjustable wrench
- Chain Lubricant - NSF H1
- Disposable latex/rubber gloves (for food grade products and to protect hands from grease)
- Hairnet and/or beard net (food grade products only)
- Sterile shoe covers (food grade products only)

## Instructions

Note: Wear latex/rubber gloves (and appropriate food grade attire if applicable) during this process.

### Method 1: Lubricate the Drive Chain and Drive Shaft

Note: To see photos of these lubrication points, please refer to the instructions on page 19.

1. Lubricate the drive chain and drive shaft, which are located inside the VH™ Powder Mixer's base.

# Cleaning

During the VH™ Powder Mixer's operation, excess powder will find its way into parts of the machine. It is important to clean the VH™ Powder Mixer thoroughly to prevent rusting and cross contamination.

LFA recommends that the machine be cleaned after each operation.

## Tools and Materials Needed

- Cleaning brush
- Bagless vacuum
- Toothbrush
- Cleaner (e.g. Member's Mark Commercial Lemon Fresh Disinfectant)
- Sanitizer (e.g. Member's Mark Commercial Sanitizer)
- Disposable latex/rubber gloves
- Bowl of warm soapy water (nothing abrasive)
- 3 clean cloths
- Potable water
- Hairnet and/or beard net (food grade products only)
- Sterile shoe covers (food grade products only)



**WARNING:** To prevent any potential personal injury, ALWAYS unplug the VH™ Powder Mixer from the electrical outlet when cleaning the machine.

## Instructions

Note: Wear latex/rubber gloves (and appropriate food grade attire if applicable) during this process.

### Remove Parts

1. Remove the V-Tank from the machine (VH 8™ and VH 14™ only).
  - 1.1 Note: Please refer to the repair and replace V-Tank instructions on page 24 for further information.
2. Remove the panels.
3. Use a brush to bring powder debris out from hard to reach places.
4. Vacuum the top section of the VH™ Powder Mixer.
5. Vacuum the entire areas inside the steel side panel door encasement.
  - 5.1 Note: Be sure to thoroughly vacuum inside the VH™ Powder Mixer's base.

### Clean the VH™ Powder Mixer

6. Take a clean cloth and carefully wash the V-Tank thoroughly with soapy water.
  - 6.1 Note: Use the toothbrush for difficult-to-remove debris.
7. Dry the V-Tank immediately after it is cleaned and rinsed.
8. Sanitize the V-Tank with a clean cloth.



### Clean the Base

9. Spray the outside and inside of the VH™ Powder Mixer base with the cleaner.
10. Rinse the cleaner off with potable water.
11. Sanitize the outside and inside of the VH™ Powder Mixer base with a clean cloth.



## Cleaning Schedule Matrix

| Part              | After Installing Machine | After Every Use     | Before Every Use     | In Between Products That Present A Cross Contamination Risk | Weekly | Monthly | Before Placing In Storage | After Removing From Storage |
|-------------------|--------------------------|---------------------|----------------------|---|--------|---------|---------------------------|-----------------------------|
| V-Tank            | Remove from machine      | Remove from machine | Install into machine | Remove from machine   | N/A    | N/A     | Remove from machine       | Install into machine        |
| VH Base (outside) | Remove from machine      | Remove from machine | Install into machine | Remove from machine   | N/A    | N/A     | Remove from machine       | Install into machine        |
| Motor             | Clean on machine         | Clean on machine    | N/A                  | Clean on machine  | N/A    | N/A     | Clean on machine          | Clean on machine            |

| Cleaning Level Key  |
|---|
| Level 1 - Remove powder   |
| Level 2 - Dry clean with cloth  |
| Level 3 - Dry clean and re-lubricate if specified in lubrication schedule   |
| Level 4 - Wet clean and re-lubricate if specified in lubrication schedule   |
| <b>Remove from machine</b> - Take part out of machine and clean if required. Store it correctly or install back into machine.                               |
| <b>Install into machine</b> - Install part into the machine and make sure that it has been cleaned. If needed, lubricate to the level required.             |
| <b>Clean on/in machine</b> - Clean the part while in the machine and do not remove it. Make sure that all contact surfaces are clean to the level required. |

This cleaning matrix is intended as a guide only and is not an exhaustive list. All cleaning schedules will need to be adapted to the industry and product, following industry regulations and the material safety data sheets that come with specific products. Please check with your Food Safety Manager/Department, Quality Control Manager/Department, or other relevant internal departments at your company before using.

# Storing the VH™ Powder Mixer

After its thorough cleaning, the VH™ Powder Mixer needs to be stored in the proper conditions. It is important to store it in an environment in which the machine is safe from rusting. The VH™ Powder Mixer's high-traction areas need to be lubricated before you store the machine.

## Tools and Materials Needed

- Plastic wrapping to cover machine
- Lubricant/grease (NSF approved lubricant if machine has a high chance of contact with the food or drug product)
- Disposable latex/rubber gloves (for food grade products and to protect hands from lubricant)
- Hairnet and/or beard net (food grade products only)
- Sterile shoe covers (food grade products only)

## Instructions

Note: Wear latex/rubber gloves (and appropriate food grade attire if applicable) during this process.

### Lubricating the High-Traction Areas

1. Apply NLGI Grade 2 grease to the bearings on the V-Tank.



2. Apply NSF H1 chain lubricant to the drive chain (from VH 100™ up to VH 500™).



## Environmental Conditions

It is important that the environment in which you store the VH™ Powder Mixer has the appropriate temperature and relative humidity levels. These two environmental factors can potentially cause the machine to rust and/or cause low quality in powder mixtures.

| Appropriate Environmental Conditions |             |       |           |
|--------------------------------------|-------------|-------|-----------|
| Machine                              | Temperature |       | Humidity  |
|                                      | °C          | °F    |           |
| VH™ Powder Mixer Range               | 18-24       | 64-75 | 45-65% RH |

# Appendix

## Glossary

| Term                                 | Definition  |
|--------------------------------------|---|
| API/Active Pharmaceutical Ingredient | Any substance or mixture of substances used that is an active ingredient in the drug product. |
| Binding agent                        | See excipient.  |
| Excipient                            | An inactive substance that serves as the vehicle or medium for a drug or other API.           |
| Formulation                          | Powder mix of the excipient and the API that is compressed to make tablets.                   |
| Granular material                    | See Formulation.  |
| V-Tank                               | The v-shaped container in which powder is mixed.  |

# Description of VH™ Powder Mixer Parts

## V-Tank

The V-Tank is the container in which the powder is contained and later mixed. The approximate fill volume capacity of the V-Tanks ranges from 8 L to 500 L.



## Input Gaskets

The Input Gaskets are a rubber seals that are located on top of the V-Tank and around the feeder points.

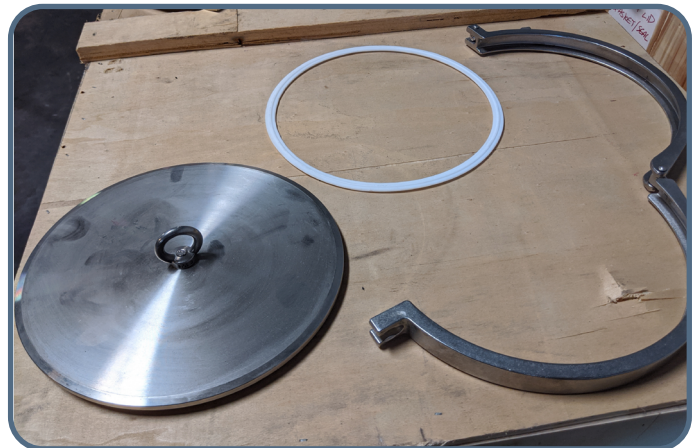

## Output Gasket

The Output Gasket is a rubber seal that is located at the bottom of the V-Tank and around the discharge chute.



## Timer

The Timer is a numerical dial that can be adjusted to set the running time for the machine.

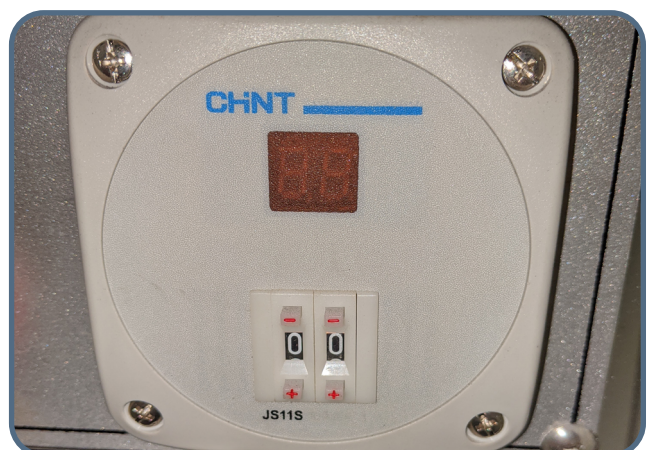



## Food Grade Point of Contact Parts

| Contact Part   | Material |
|--|----------|
| V-Tank (including feeder points and discharge chute) | SUS304   |

## Technical Specifications

| Model  | VH 8                                    | VH 14                               | VH 100                            | VH 150                            | VH 200                             | VH 300                              | VH 500                             |
|--|---|-------------------------------------|-----------------------------------|-----------------------------------|------------------------------------|-------------------------------------|------------------------------------|
| Barrel capacity                                  | 8 L / 0.28 ft <sup>3</sup>              | 14 L / 0.49 ft <sup>3</sup>         | 100 L / 3.5 ft <sup>3</sup>       | 150 L / 5.3 ft <sup>3</sup>       | 200 L / 7.06 ft <sup>3</sup>       | 300 L / 10.59 ft <sup>3</sup>       | 500 L / 17.65 ft <sup>3</sup>      |
| Approximate working capacity (weight)            | 2.5 kg / 5.5 lbs                        | 4 kg / 9 lbs                        | 28 kg / 62 lbs                    | 50 kg / 110 lbs                   | 55 kg / 121 lbs                    | 80 kg / 175 lbs                     | 140 kg / 308 lbs                   |
| Approximate working capacity (volume)            | 3.2-4.8 L / 0.11 - 0.17 ft <sup>3</sup> | 5.6-8.4 L / 0.2-0.3 ft <sup>3</sup> | 40-60 L / 1.4-2.1 ft <sup>3</sup> | 60-90 L / 1.4-3.1 ft <sup>3</sup> | 80-120 L / 2.8-4.2 ft <sup>3</sup> | 120-180 L / 4.2-6.3 ft <sup>3</sup> | 200-300 L / 7-10.5 ft <sup>3</sup> |
| Agitation speed (r/min)                          | 24                                      | 20                                  | 15                                | 15                                | 12                                 | 12                                  | 12                                 |
| Mixing time (min)                                | 6-8                                     | 6-8                                 | 6-8                               | 6-8                               | 6-8                                | 6-10                                | 6-10                               |
| USA Power (±10%)                                 | 0.25 kW, 1 phase, 240 V                 | 0.37 kW, 1 phase, 110 V             | 1.1 kW, 3 phase, 220 V            | 1.1 kW, 3 phase, 220 V            | 1.5 kW, 3 phase, 220 V             | 1.5 kW, 3 phase, 220 V              | 2.2 kW, 3 phase, 220 V             |
| UK Power (±10%)                                  | 0.25 kW, 1 phase, 240 V                 | 0.37 kW, 1 phase, 240 V             | 1.1 kW, 3 phase, 440 V            | 1.1 kW, 3 phase, 440 V            | 1.5 kW, 3 phase, 440 V             | 1.5 kW, 3 phase, 440 V              | 2.2 kW, 3 phase, 440 V             |
| Dimensions (mm)                                  | 600 x 500 x 500                         | 900 x 380 x 900                     | 1900 x 800 x 1190                 | 1900 x 800 x 1730                 | 2400 x 950 x 1510                  | 2100 x 650 x 1850                   | 2550 x 1000 x 1950                 |
| Dimensions with suggested working clearance (mm) | 1500 x 1400 x 1400                      | 1800 x 2280 x 1800                  | 2800 x 1700 x 2090                | 2800 x 1700 x 2630                | 3300 x 1850 x 2410                 | 3000 x 1550 x 2750                  | 3450 x 1900 x 2850                 |
| Machine weight                                   | 75 kg / 165 lbs                         | 83 kg / 182 lbs                     | 200 kg / 440 lbs                  | 250 kg / 551 lbs                  | 300 kg / 661 lbs                   | 350 kg / 771 lbs                    | 550 kg / 1,212 lbs                 |

# Maintenance Checklist

| <b>Before Operation</b>  |   |
|--------------------------|---|
| <input type="checkbox"/> | Visually inspect the VH™ Powder Mixer and the parts.  |
| <input type="checkbox"/> | Ensure all nuts and bolts are tight.  |
| <input type="checkbox"/> | Visually inspect lubrication points and grease where necessary.   |
| <input type="checkbox"/> | Inch/jog the machine without powder.  |
| <input type="checkbox"/> | Visually inspect electrical wires for any damage.   |
| <b>During Operation</b>  |   |
| <input type="checkbox"/> | Listen for irregular knocking or clicking sounds. If heard, stop operation and inspect the VH™ Powder Mixer's interior.                                 |
| <input type="checkbox"/> | Occasionally check the Motor's temperature. If it starts to overheat, turn off the machine, let it cool down, and grease it to ensure smooth operation. |
| <input type="checkbox"/> | Check to see that the Emergency Stop properly works.  |
| <b>After Operation</b>   |   |
| <input type="checkbox"/> | Unplug machine and remove all excess powder with a bagless vacuum.  |
| <input type="checkbox"/> | Remove the V-Tank and thoroughly clean its interior and exterior.   |
| <input type="checkbox"/> | Wipe down the other surfaces with a damp cloth.   |
| <input type="checkbox"/> | Apply a layer of NSF approved grease to the high-traction areas.  |

# Diagrams

## VH 14™ Wiring Diagram

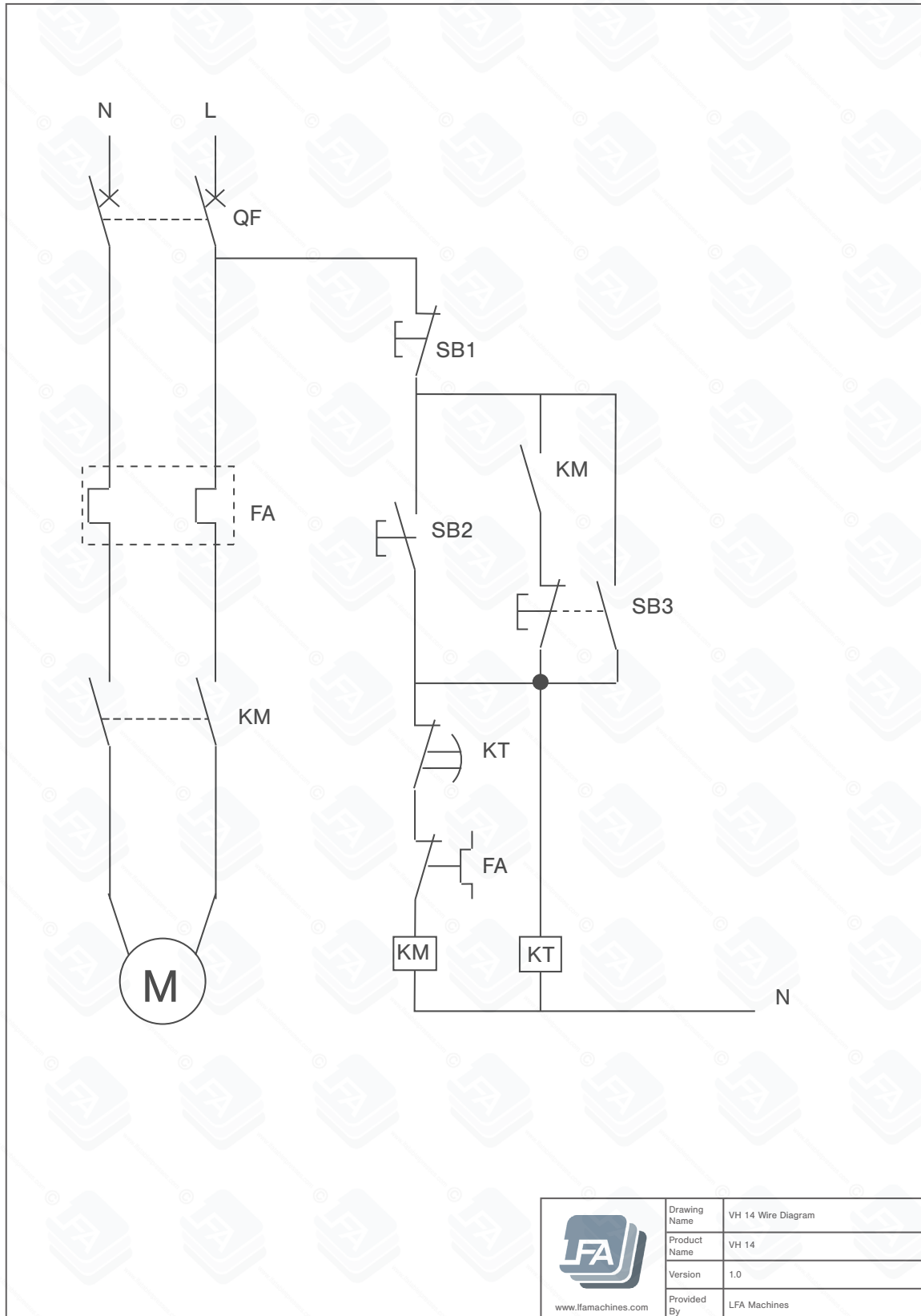

|   |              |                    |
|---|--------------|--------------------|
| <br>www.lfamachines.com | Drawing Name | VH 14 Wire Diagram |
|   | Product Name | VH 14              |
|   | Version      | 1.0                |
|   | Provided By  | LFA Machines       |

# VH 100™ Electrical Drawing 1

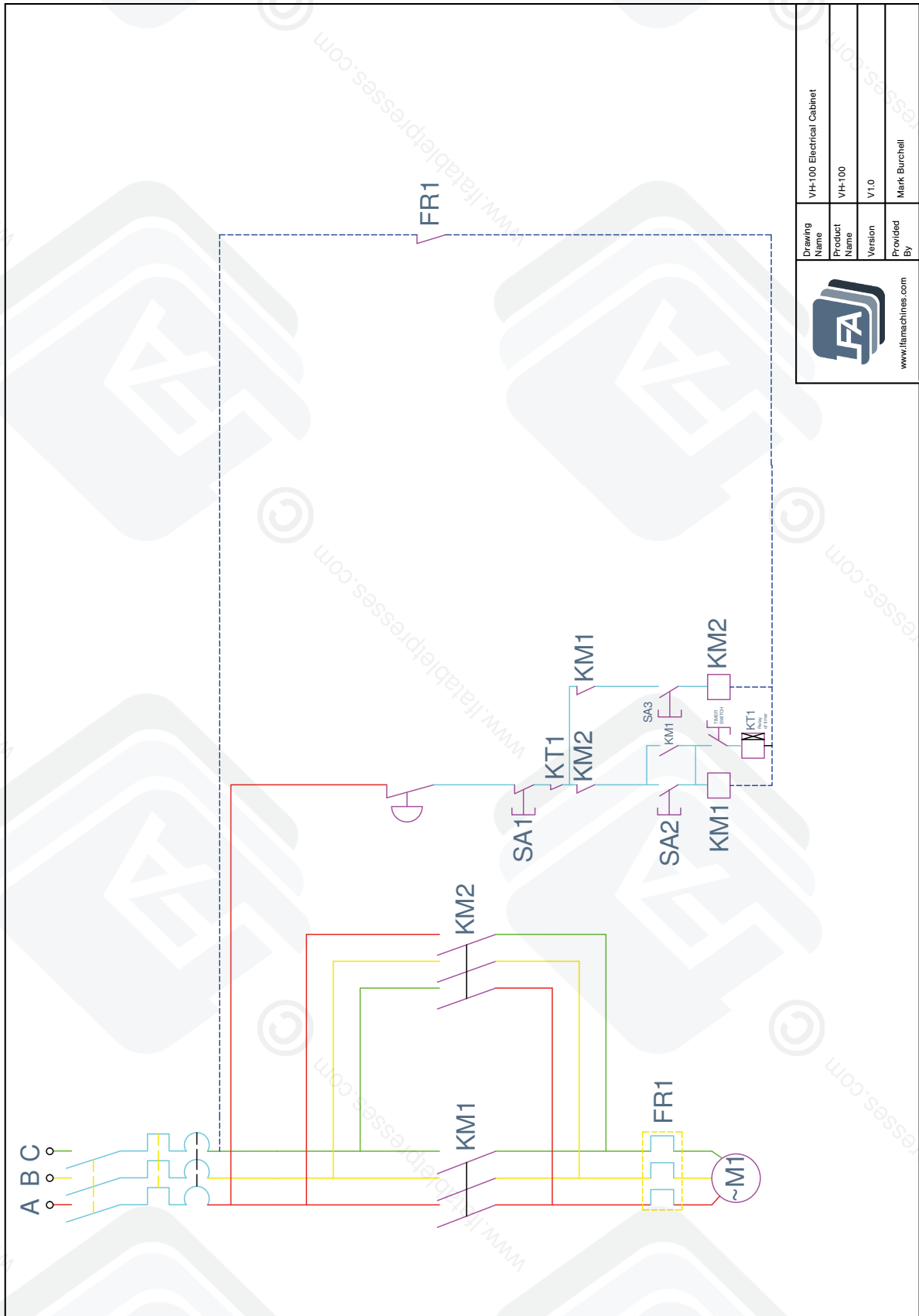

|   |              |                           |
|---|--------------|---------------------------|
| <br>www.famachines.com | Drawing Name | VH-100 Electrical Cabinet |
|   | Product Name | VH-100                    |
|   | Version      | V1.0                      |
|   | Provided By  | Mark Burchell             |

# VH 100™ Electrical Drawing 2

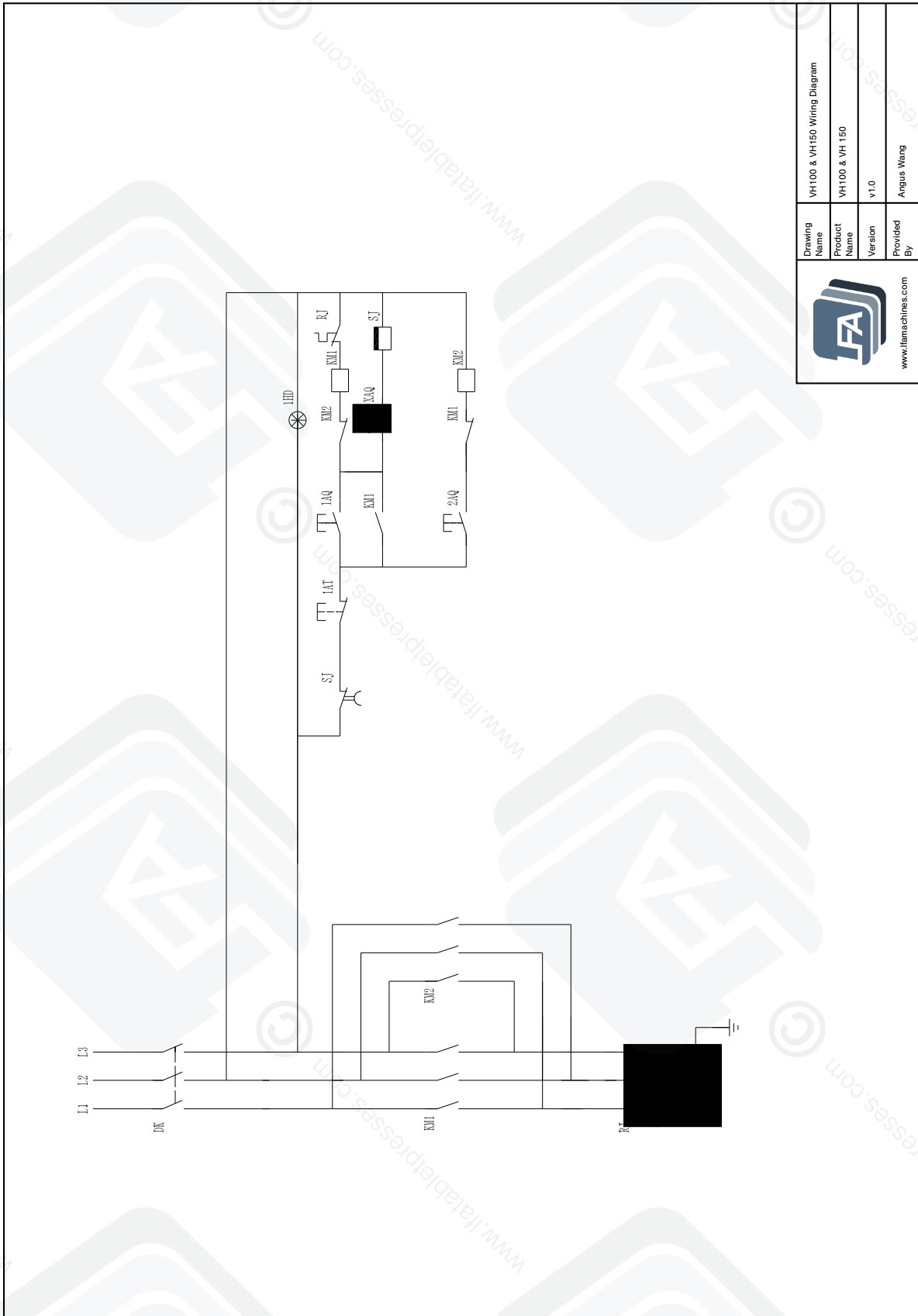

|   |              |                              |
|---|--------------|------------------------------|
| <br>www.famachines.com | Drawing Name | VH100 & VH150 Wiring Diagram |
|   | Product Name | VH100 & VH150                |
|   | Version      | v1.0                         |
|   | Provided By  | Argus Wang                   |

# VH 8™ Dimensions

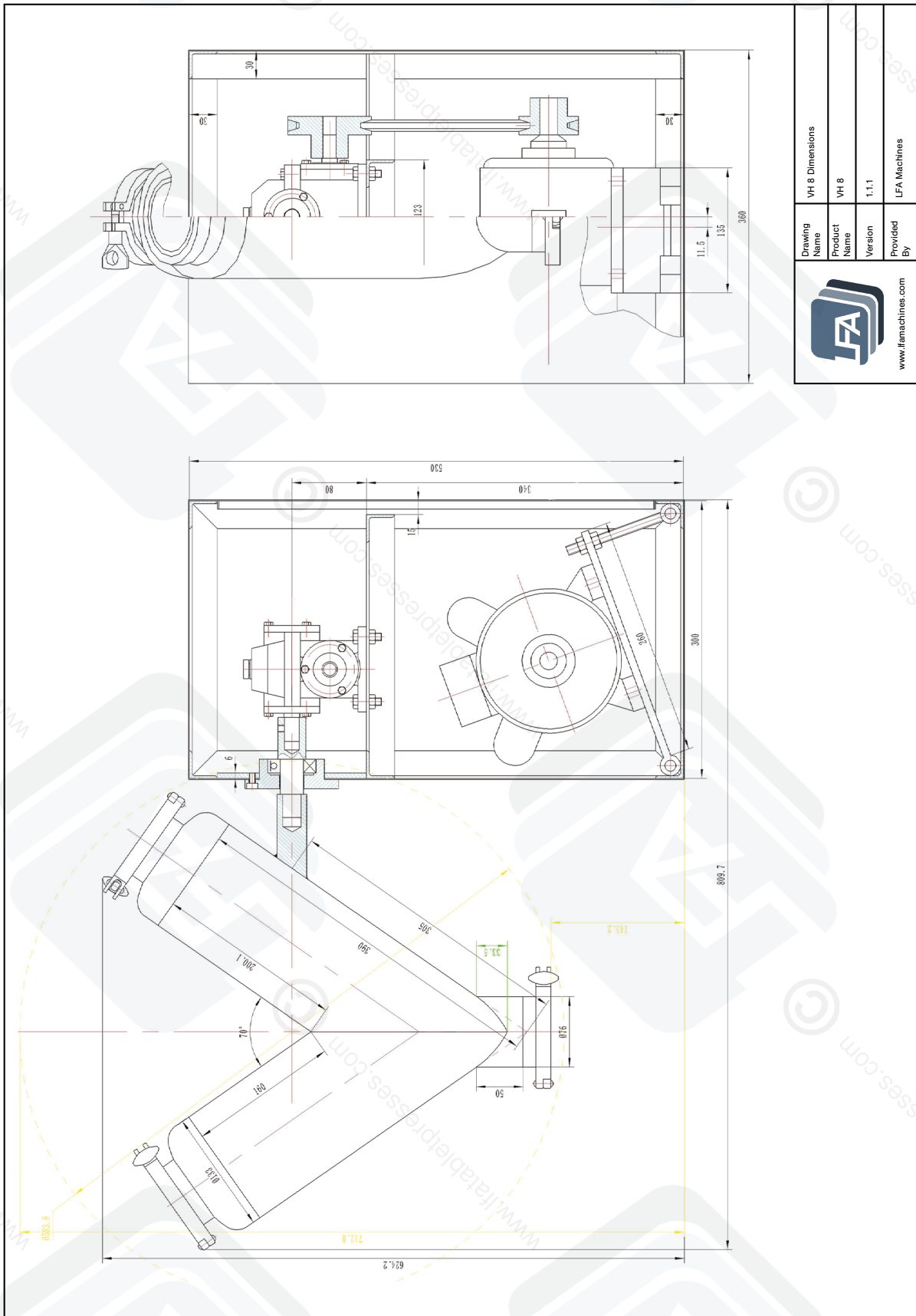

|  |              |                 |
|--|--------------|-----------------|
| <br>www.lfamachines.com | Drawing Name | VH 8 Dimensions |
|  | Product Name | VH 8            |
|  | Version      | 1.1.1           |
|  | Provided By  | LFA Machines    |

# VH 14™ Dimensions

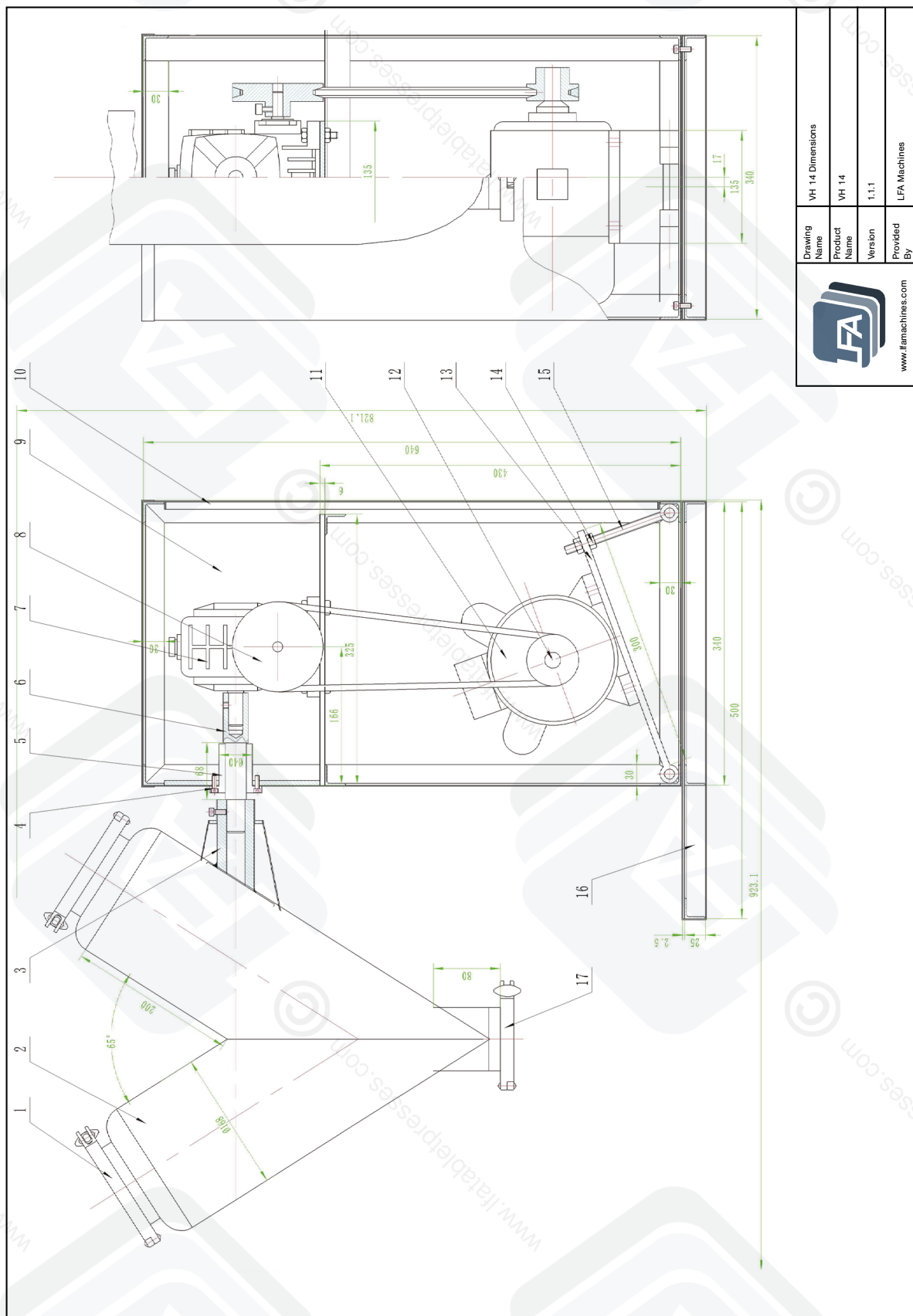

|  |              |                  |
|--|--------------|------------------|
| <br>www.lfamachines.com | Drawing Name | VH 14 Dimensions |
|  | Product Name | VH 14            |
|  | Version      | 1.1.1            |
|  | Provided By  | LFA Machines     |

# VH 100™ Dimensions

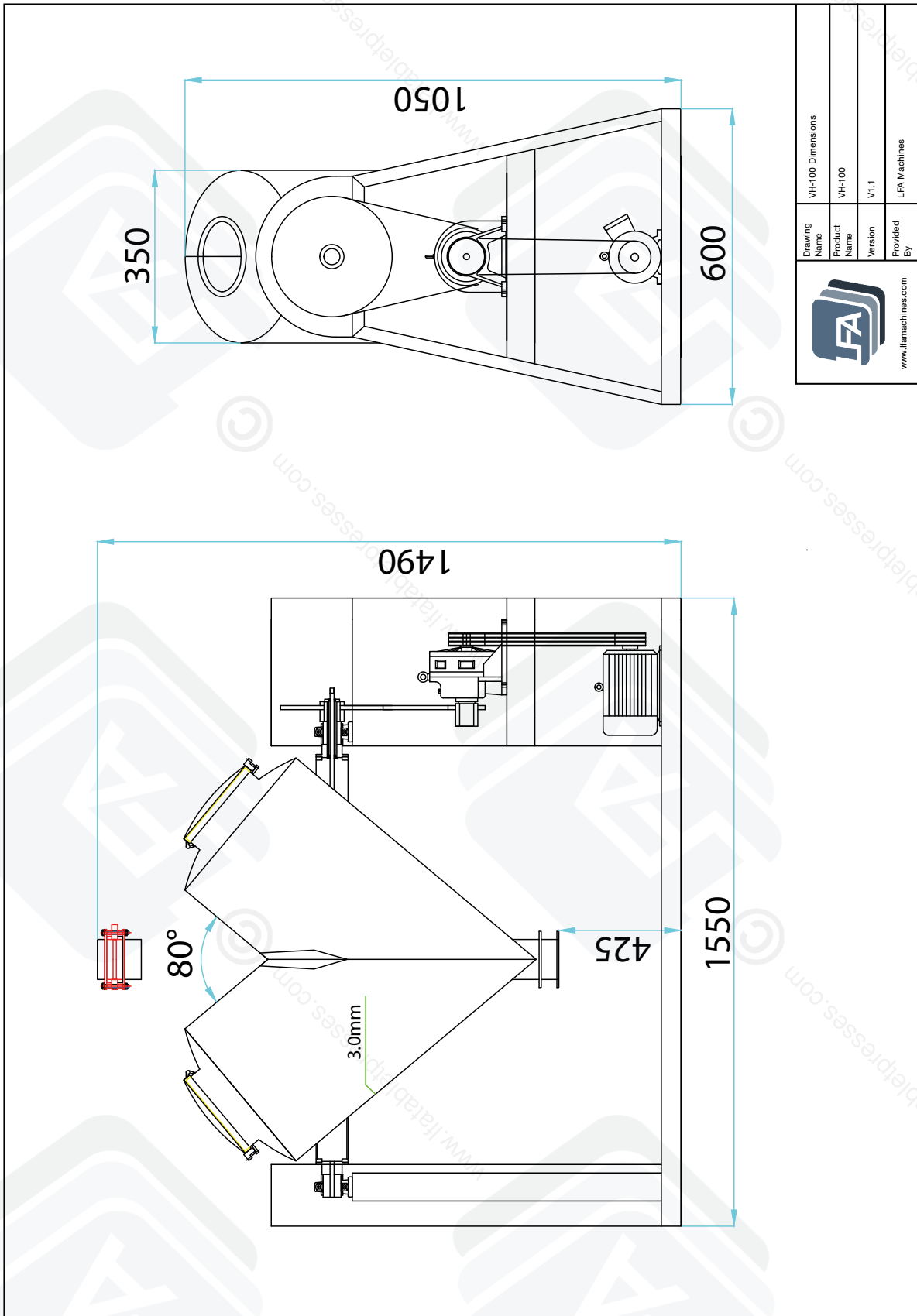

|  |              |                   |  |  |
|--|--------------|-------------------|--|--|
| <br>www.lfamachines.com | Drawing Name | VH-100 Dimensions |  |  |
|  | Product Name | VH-100            |  |  |
|  | Version      | V1.1              |  |  |
|  | Provided By  | LFA Machines      |  |  |



# VH 150™ Dimensions

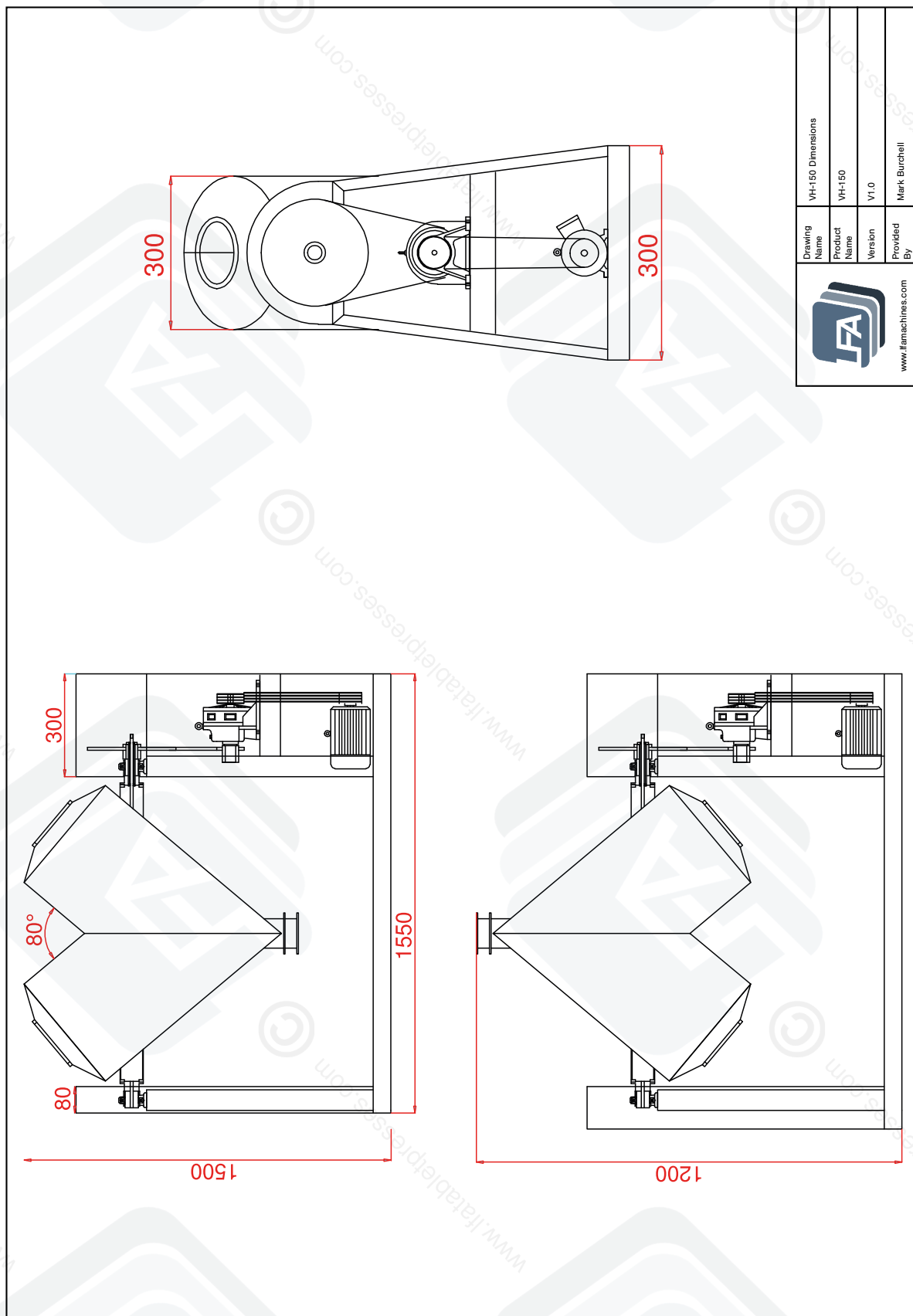

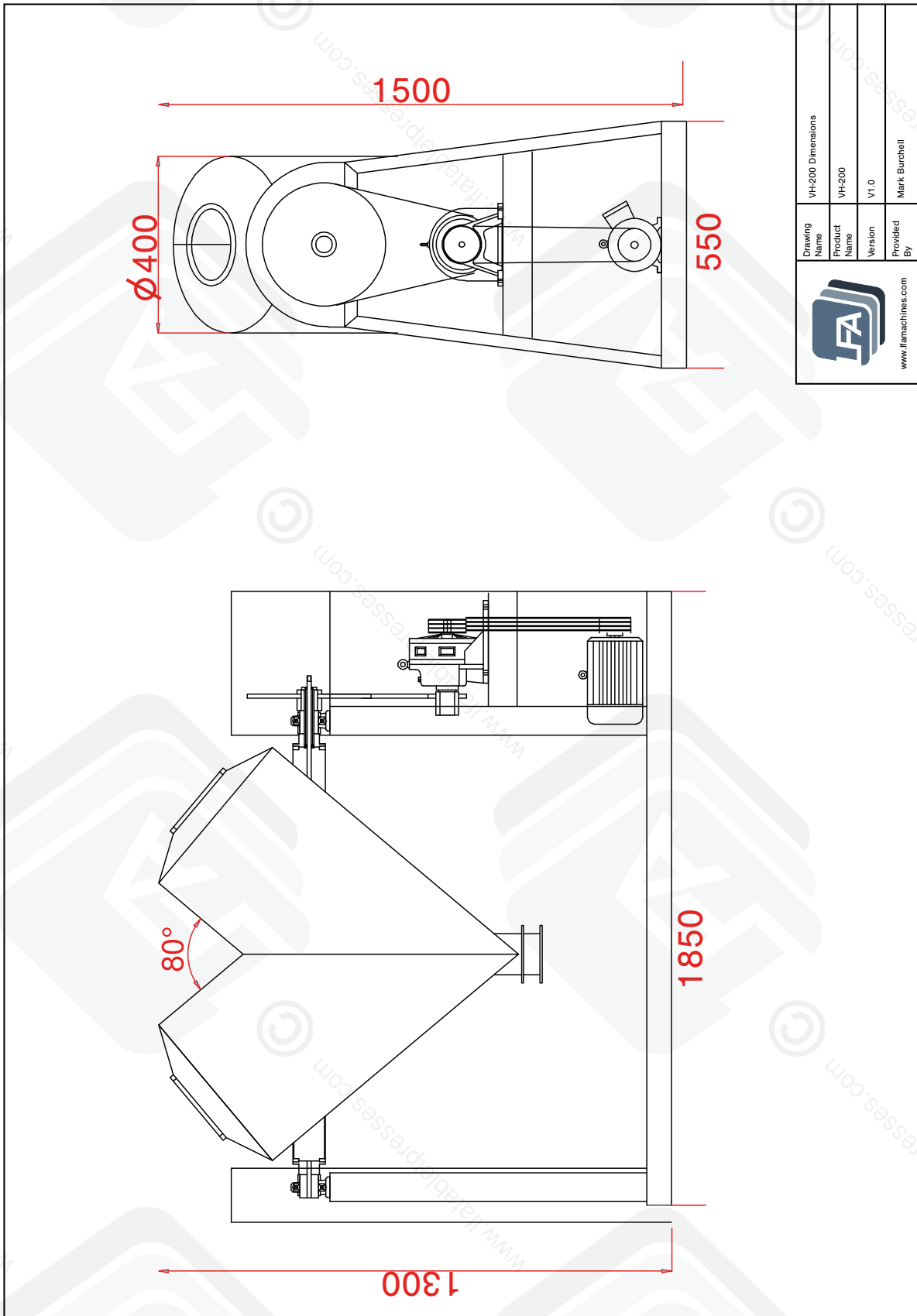

# VH 200™ Dimensions

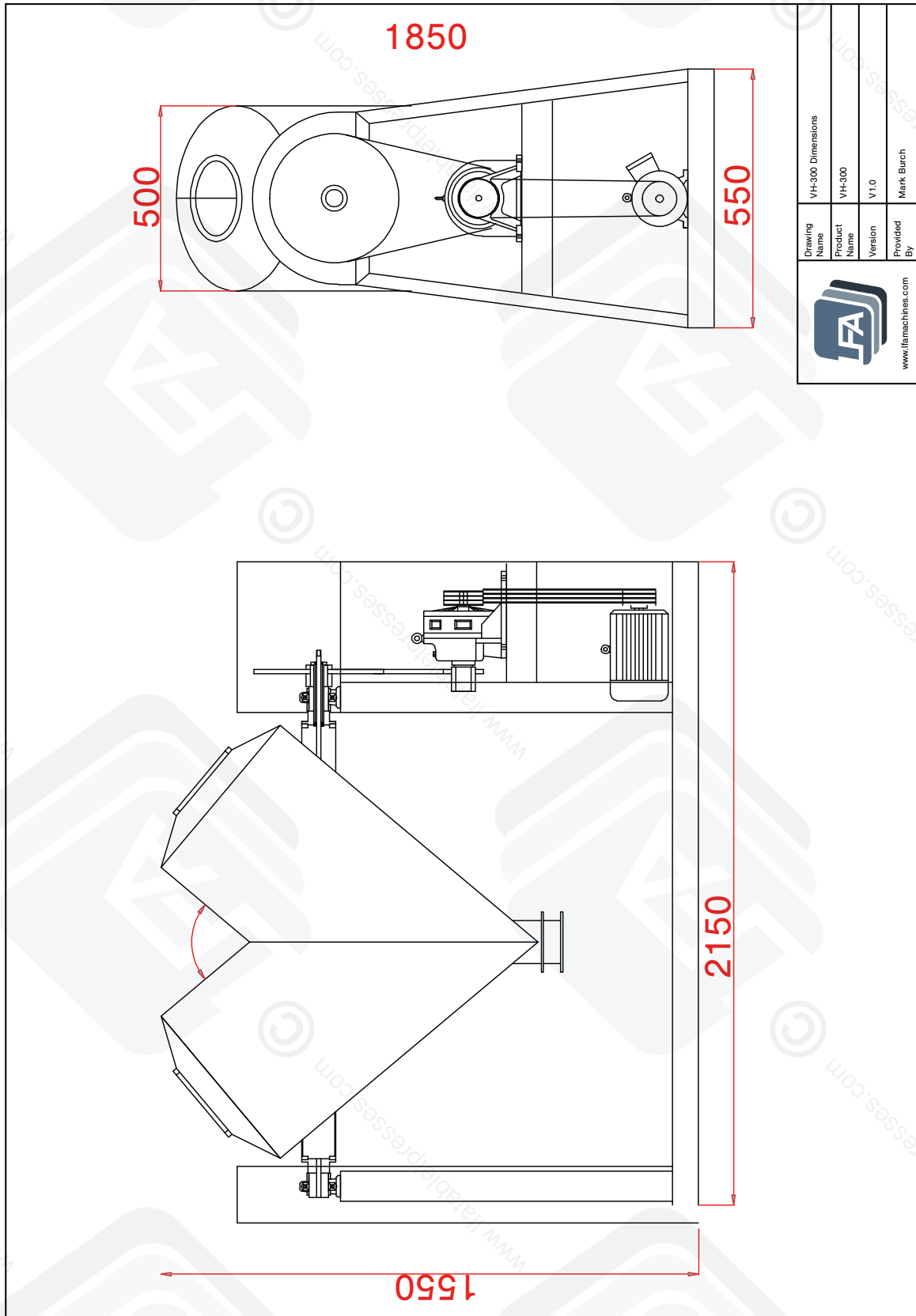

|   |              |                   |  |  |
|---|--------------|-------------------|--|--|
|  | Drawing Name | VH-200 Dimensions |  |  |
|   | Product Name | VH-200            |  |  |
|   | Version      | V1.0              |  |  |
|   | Provided By  | Mark Burchell     |  |  |
|   |              |                   |  | <a href="http://www.flamachines.com">www.flamachines.com</a> |

# VH 300™ Dimensions



|  |              |                   |
|--|--------------|-------------------|
| <br>www.ifamachines.com | Drawing Name | VH-300 Dimensions |
|  | Product Name | VH-300            |
|  | Version      | V1.0              |
|  | Provided By  | Mark Burch        |

# VH 500™ Dimensions/Floor Plan

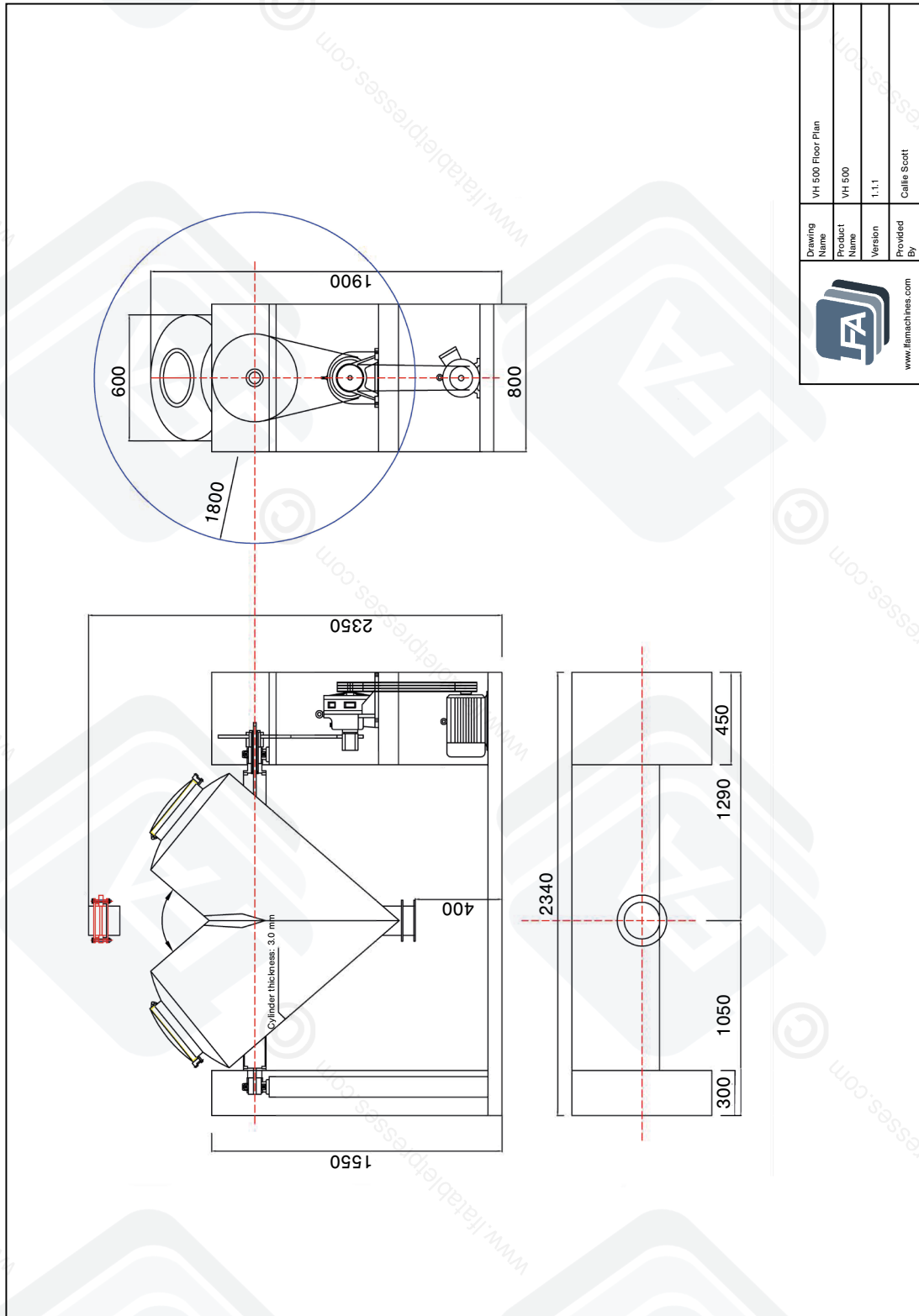

# Resources

## Helpful Links

### Warranty

For information regarding the warranty policy of the VH™ Powder Mixer and other LFA products, please visit <https://www.lfatabletpresses.com/warranty>

### LFA Website

In order to aid you in your powder mixing, LFA Machines maintains a website that offers a breadth of useful information about the VH™ Powder Mixer and other powder mixers. You can watch videos or read our regularly published articles that cover a whole range of topics about powder mixing and tablet/capsule production.

Visit the LFA homepage at <https://www.lfatabletpresses.com>

### LFA Machines YouTube Channel

Our YouTube videos provide you an opportunity to see demonstrations of how to use our mixers, common troubleshooting tips, and other LFA products such as capsule fillers and tablet presses. We regularly upload videos to give you a visual aid that will hopefully support you in your powder mixing efforts. To watch our videos, visit <https://www.youtube.com/channel/UCwtbcwja77ai7vX2o34FUkQ>

### LFA Machines Social Media

Social media is a great way to keep yourself updated on new developments and exciting things happening at LFA Machines. The list below contains our current social media pages:

Twitter: @lfatabletpress

Instagram: @lfatabletpresses

Facebook: <https://www.facebook.com/lfatabletpresses>

LinkedIn: <https://www.linkedin.com/company/lfa-machines-oxford-ltd/>

## Contact Us

### UK

LFA Machines Oxford Ltd  
Unit 4B Rowood Estate  
Murdock Road  
Bicester, Oxfordshire OX26 4PP  
+44 01869 250234  
[support.uk@lfamachines.com](mailto:support.uk@lfamachines.com)  
Monday-Friday  
9AM-5PM GMT

### USA

LFA Machines DFW, LLC  
6601 Will Rogers Blvd  
Fort Worth, TX 76140  
+1 (682) 312 0034  
[support.usa@lfamachines.com](mailto:support.usa@lfamachines.com)  
Monday-Friday  
8AM-6PM UTC (Central)

### Germany

LFA Machines Düsseldorf GmbH  
Business Parc Am Trippelsberg 92  
Düsseldorf, North-Rhine  
Westphalia 40589  
+41 21188250223  
[verkauf@lfamachines.com](mailto:verkauf@lfamachines.com)

### Taiwan

LFA Machines Taiwan Ltd  
7F-5, No. 2, Sec. 2 Taiwan Blvd  
West District, Taichung City 403  
Taiwan  
+886 422031790  
[support.asia@lfamachines.com](mailto:support.asia@lfamachines.com)  
Monday-Friday  
9AM-5PM GMT+8



LFA MACHINES

Copyright © 2022 by LFA Machines

[www.lfamachines.com](http://www.lfamachines.com)

**United Kingdom**

Unit 4B  
Murdock Road  
Bicester  
Oxfordshire  
United Kingdom  
OX26 4PP

**United States**

6601 Will Rogers Blvd  
Fort Worth  
Texas  
United States  
76140

**Germany**

Business Parc Am  
Trippelsberg 92  
Düsseldorf  
Germany  
40589

**Taiwan**

7F.-5, No. 2, Sec. 2  
Taiwan Blvd., West Dist.,  
Taichung City 403,  
Taiwan